

PA ST RY 2020

Index

02 Intro

08 Chocolate

- 10** Easter
- 34** Christmas
- 54** Fashion & style
- 58** Sign your creation
- 68** Choco bar moulds
- 78** Bonbons praline moulds
- 82** Iconic praline moulds
- 86** Abyss praline moulds
- 90** Praline moulds
- 104** Chocolate moulds
- 116** Chocolate decoration
- 125** Chocolate equipment

128 Pastry

- 132** Cédric Grolet
- 138** Progetto Crostate
- 172** My Valentine
- 178** Catering
- 180** Monoporzioni - *Single-serving portions*
- 214** Mignon
- 226** Cakes
- 258** Top
- 266** Tronchetti - Logs
- 276** Tronchetti porzionabili - *Portionable logs*
- 280** Sphere
- 286** Quenelle
- 290** Éclair mania
- 294** Formasil
- 302** Formaflex
- 312** Stampi monouso - *Disposable moulds*

316 Gelato

- 318** Rainbow Stick
- 324** Gelato decoration
- 326** Gelato stick

332 Colours & raw materials



- 334** Magic Decor
- 338** Artistic sugar
- 342** Colori e materie prime - *Colours & raw materials*

358 Equipment

- 362** Covering
- 364** Vassoietti - Trays
- 369** Packaging
- 370** Tappetini in silicone - *Silicone mats*
- 376** Attrezzature - *Tools*



—
Passion



PART OF THE ART

C'è qualcosa di particolare nelle mani dei pasticceri. Pavoni Italia è al loro fianco con una collezione nuova e ricchissima. Un catalogo intero di prodotti per trasformare ogni idea in emozione, ogni visione in realtà, ogni gesto in arte. Strumenti per professionisti realizzati senza compromessi. Alla ricerca della forma e della texture perfetta.

Scopri subito. La nuova collezione Pastry 2020 di Pavoni Italia è qui.

There's something special in the hands of Pastry Chefs. Pavoni Italia is by their side with a new and extensive collection. An entire catalogue full of products to transform every idea into emotion, every vision into reality, every gesture into art. Tools for professionals designed without compromise. In search of the perfect shapes and textures.

Discover them now. The new 2020 Pastry collection by Pavoni Italia is here.

Professionisti per i professionisti

Sono oltre 6.000 i prodotti destinati ai professionisti della pasticceria e gelateria. Nata nel 1980 come produttrice di contenitori in plastica per il mondo della panificazione, oggi Pavoni Italia è azienda di riferimento nel mondo. Un marchio italiano con una storia riconosciuta di attenzione alle esigenze dei professionisti, che conosce da vicino la differenza tra semplici strumenti di lavoro e oggetti votati all'eccellenza, capaci di ispirare la creatività dei pasticceri.

Professionals for professionals

More than 6,000 products designed for professionals in the pastry and gelato industry. Founded in 1980 as a manufacturer of plastic containers for bakeries, today Pavoni Italia is a global benchmark company. An Italian brand with a proven track record of paying the utmost attention to the needs of professionals. A brand that knows the difference between simple work tools and products designed for excellence, capable of inspiring the creativity of Pastry Chefs.

—
Productivity





—
Pride

La pasticceria è arte. E Pavoni Italia la guarda con occhi nuovi.

Dalle mani dei migliori pasticceri mondiali nascono capolavori unici, ricchi di dettagli preziosi. Tutti i prodotti Pavoni Italia nascono dalla collaborazione coi migliori professionisti del settore, per dare loro i migliori strumenti, capaci di tradurre in forme concrete le idee delle migliori menti creative. Una costante ricerca di materiali, design e soluzioni tecniche per rendere funzionale ogni prodotto. E unica ogni tua realizzazione.

Pastry making is art. And Pavoni Italia looks upon it with brand new eyes.

From the hands of the world's best Pastry Chefs come unique masterpieces, rich in precious details. All Pavoni Italia products are the fruit of our collaboration with the finest professionals in the industry, so as to provide them with the best tools in translating the ideas of the greatest creative minds into concrete shapes. We are constantly searching for materials, design and technical solutions to make each product functional and every one of your creations unique.

**CHO
COL
ATE**

Easter



Stampi termoformati
Thermoformed moulds

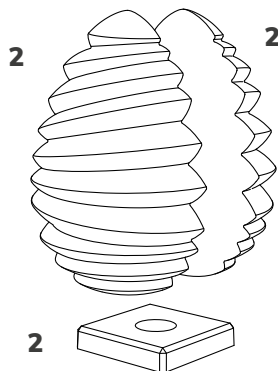

KT187
Pagoda

NEW

mm 137x137x212 h
~ 300 g

PACKAGING: KS32

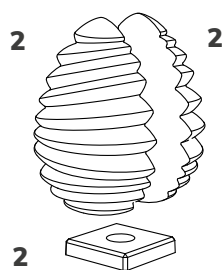

KT186
Pagoda

NEW

mm 98x98x151 h
~ 150 g

PACKAGING: KS26

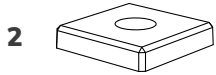
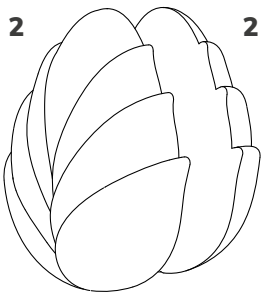

KT190
Blossom

NEW

mm 144x133x212 h
~ 370 g

PACKAGING: KS32



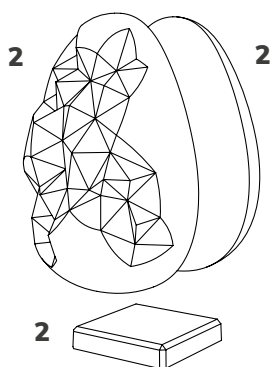

KT172
Picasso

Ø mm 140x215 h
~ 450 g

PACKAGING: KS32

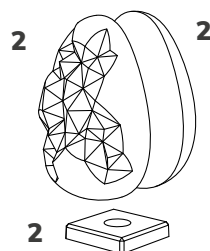

KT188
Picasso

Ø mm 96x150 h
~ 170 g

PACKAGING: KS26

NEW



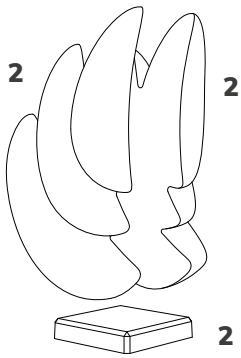

KT182
Sydney

NEW

mm 140x125x250 h
~ 390 g



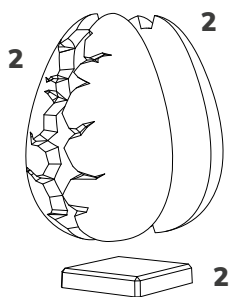

KT183

Abyss

by Davide Comaschi

NEW

Ø mm 140x215 h
~ 340 g

PACKAGING: KS32



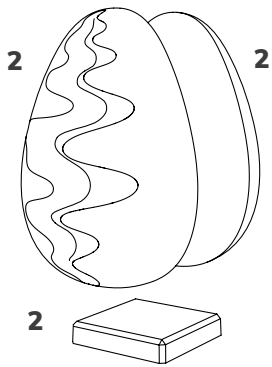

KT173

Senna

Ø mm 140x215 h
~ 450 g

PACKAGING: KS32



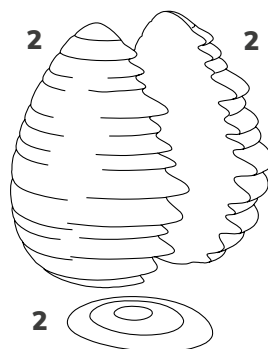

KT138
Speed

mm 135x165x200 h
~ 430 g

PACKAGING: KS32

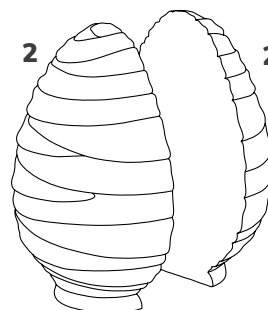

KT139
Ramses

Ø mm 140x200 h
~ 330 g

PACKAGING: KS32

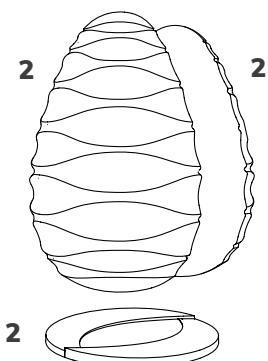

KT157
Beauty

Ø mm 130x205 h
~ 400 g

PACKAGING: KS32

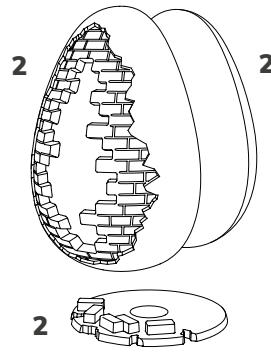

KT168
The Wall

Ø mm 140x200 h
~ 420 g

PACKAGING: KS32

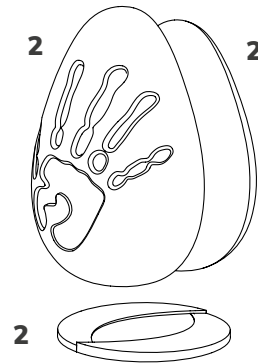

KT156
Hello

Ø mm 130x205 h
~ 380 g

PACKAGING: KS32

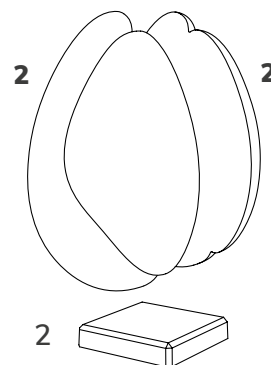

KT174
Grain

Ø mm 135x215 h
~ 400 g

PACKAGING: KS32

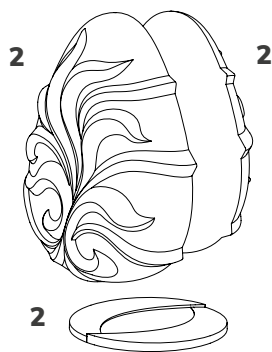

KT167
Barocco

Ø mm 145x200 h
~ 420 g

PACKAGING: KS32

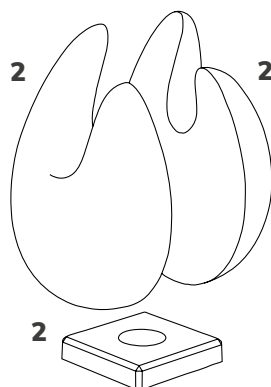

KT140
Organic

Ø mm 135x215 h
~ 330 g

PACKAGING: KS32

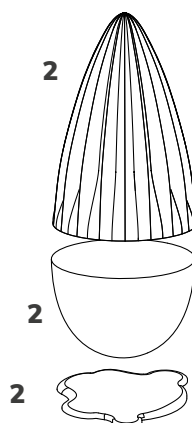

KT130
Squeezer

Ø mm 120x250 h
~ 300 g

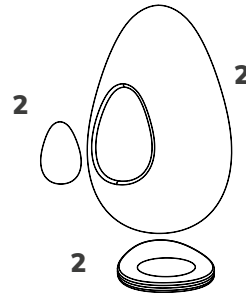

KT50
Lamp

Ø mm 110x160 h
~ 300 g

PACKAGING: KS26

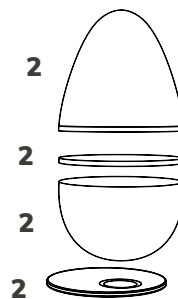

KT51
Deck

mm 135x100x165 h
~ 300 g

PACKAGING: KS26

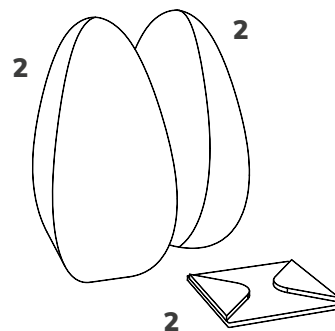

KT70
Stele

mm 90x90x200 h
~ 350 g

PACKAGING: KS26

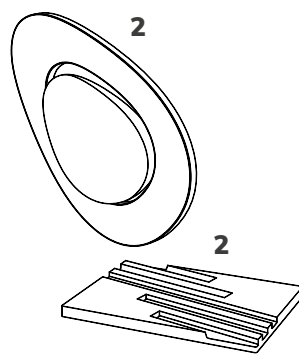

KT71
Swing

mm 130x90x200 h
~ 250 g

PACKAGING: KS26

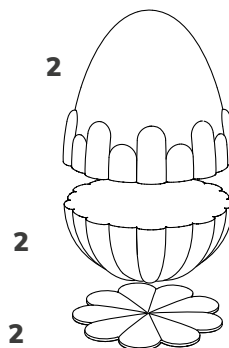

KT129
Nest

Ø mm 150x200 h
~ 400 g

PACKAGING: KS32

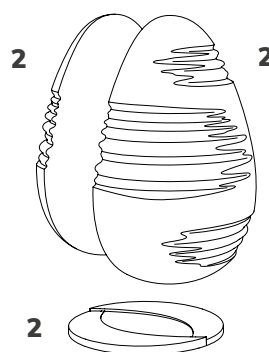

KT169
Nick

Ø mm 130x200 h
~ 380 g

PACKAGING: KS26

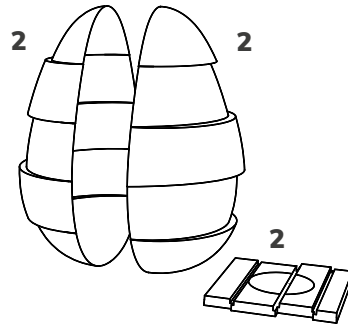

KT74
Split

Ø mm 140x200 h
~ 400 g

PACKAGING: KS32

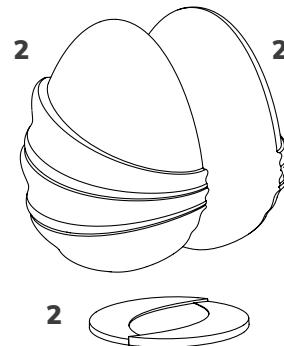

KT76
Wrap

Ø mm 150x200 h
~ 350 g

PACKAGING: KS32

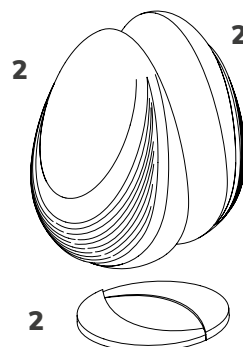

KT77
Comb

Ø mm 140x200 h
~ 350 g

PACKAGING: KS32

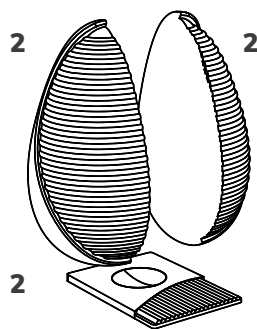

KT90
Stripe

Ø mm 130x200 h
~ 350 g

PACKAGING: KS26

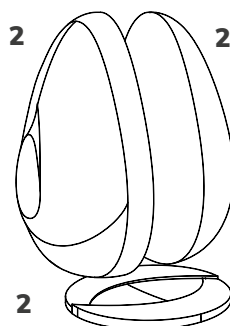

KT91
Mirror

Ø mm 130x200 h
~ 350 g

PACKAGING: KS26

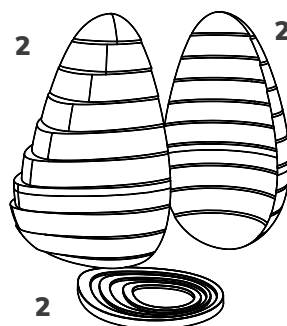

KT92
Galà

Ø mm 130x200 h
~ 350 g

PACKAGING: KS32

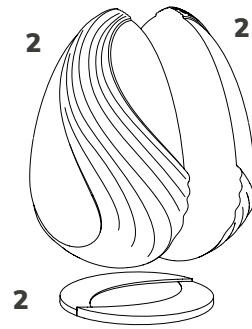

KT78
Pinup

Ø mm 140x200 h
~ 350 g

PACKAGING: KS32

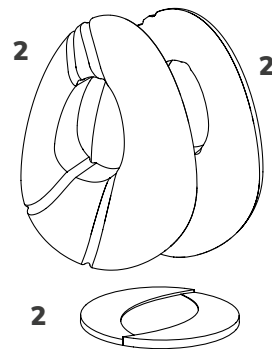

KT79
Spaceship

Ø mm 140x200 h
~ 350 g

PACKAGING: KS32

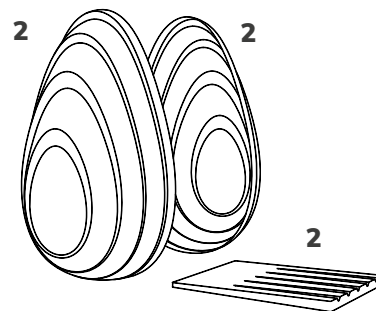

KT72
Level

Ø mm 130x200 h
~ 400 g

PACKAGING: KS26

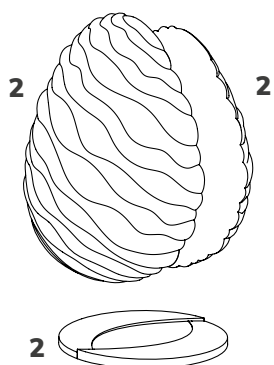

KT158
Fluid

Ø mm 140x205 h
~ 380 g

PACKAGING: KS32

photo credits:
Carlo Cracco



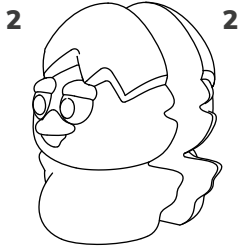

KT189
Bomber

NEW

mm 132x125x160 h
~ 200 g

PACKAGING: KS26



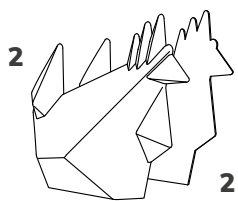

KT184
Rocky Rooster

NEW

mm 170x105x150 h
~ 120 g

PACKAGING: KS26

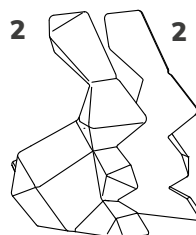

KT185
Rocky Roger

NEW

mm 145x95x180 h
~ 170 g

PACKAGING: KS26



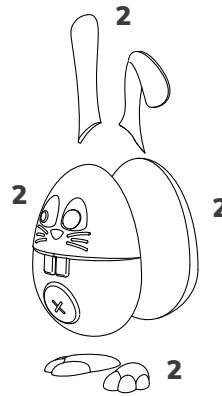

KT131
Eddie

Ø mm 100x210 h
~ 170 g

PACKAGING: KS32

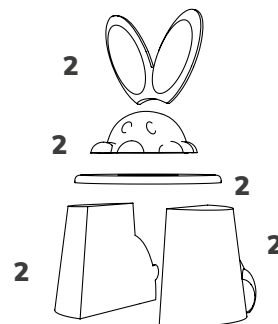

KT154
Magic Bunny

mm 100x120x170 h
~ 200 g

PACKAGING: KS26

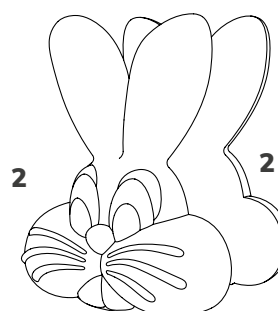

KT170
Roger

mm 155x110x200 h
~ 270 g

PACKAGING: KS26

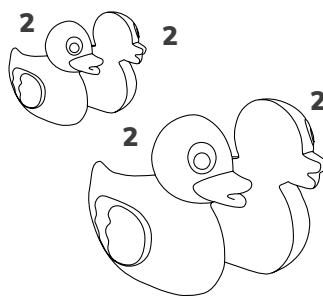

KT142
Papera+Paperella

2 soggetti - 2 items

mm 60x45x75 h
 ~ 40 g

mm 112x80x136 h
 ~ 120 g



KT143
Pecorella

mm 160x100x125 h
 ~ 180 g

PACKAGING: KS26

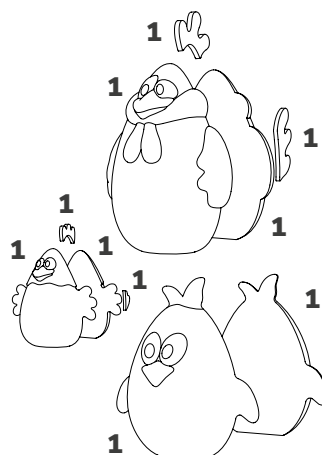

KT155
Kit Chicken Family

3 soggetti - 3 items

mm 120x135x190 h
 ~ 200 g

mm 135x110x145 h
 ~ 150 g

mm 85x75x90 h
 ~ 90 g



Stampi termoformati serigrafati Silkscreened thermoformed moulds

Misura foglio: mm 340x265
Il numero di impronte si intende per scatola

Sheet size: mm 340x265
The number of indents is per box



T856

NEW

mm 40 h
9 modelli
4 colori
10 fogli
540 impronte
9 designs
4 colours
10 sheets
540 indents



T857

NEW

mm 40 h
9 modelli
4 colori
10 fogli
540 impronte
9 designs
4 colours
10 sheets
540 indents



T605

mm 26x40 h
3 colori
10 fogli
450 impronte
3 colours
10 sheets
450 indents

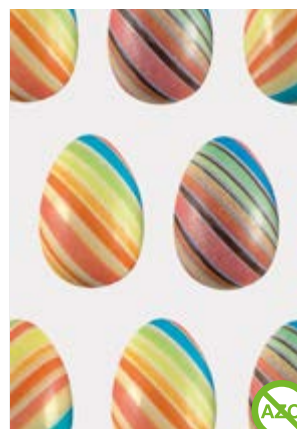

T608

mm 26x40 h
10 fogli
450 impronte
10 sheets
450 indents



T830

mm 18x29 h
4 modelli
10 fogli
630 impronte
4 designs
10 sheets
630 indents



T832

mm 43x63 h
2 colori
10 fogli
240 impronte
2 colours
10 sheets
240 indents



T111

mm 26x40 h

3 colori
10 fogli
450 impronte

3 colours
10 sheets
450 indents



T966

mm 66x100 h

4 modelli
10 fogli
80 impronte

4 designs
10 sheets
80 indents



T611

mm 26x40 h

5 modelli
3 colori
10 fogli
450 impronte

5 designs
3 colours
10 sheets
450 indents



T965

mm 26x40 h

5 modelli
3 colori
10 fogli
450 impronte

5 designs
3 colours
10 sheets
450 indents



T831

mm 43x63 h

2 modelli
10 fogli
240 impronte

2 designs
10 sheets
240 indents



T843

mm 90 h

2 modelli
24 fogli
576 impronte
(288 uova intere)

2 designs
24 sheets
576 indents
(288 whole eggs)



T839

mm 50 h

4 modelli
10 fogli
280 impronte

4 designs
10 sheets
280 indents



T840

mm 60-70 h

3 modelli
10 fogli
240 impronte

3 designs
10 sheets
240 indents





T841

mm 55 h

3 modelli
10 fogli
240 impronte

3 designs
10 sheets
240 indents



T849

mm 35 h

4 modelli
10 fogli
480 impronte

4 designs
10 sheets
480 indents



T850

mm 40 h

3 modelli
10 fogli
540 impronte

3 designs
10 sheets
540 indents



T851

mm 35 h

3 modelli
10 fogli
540 impronte

3 designs
10 sheets
540 indents



T848

mm 105 h

kit per creare 60 conigli
(20 per modello, 10 fogli)

kit to create 60 rabbits
(20 per design, 10 sheets)



T844

mm 105 h

kit per creare 27 galline
(9 per modello, 3 fogli)

kit to create 27 chickens
(9 per design, 3 sheets)



T803

mm 50 h

7 modelli - 10 fogli
200 impronte
7 designs - 10 sheets
200 indents

Kit 200 sacchetti + 200
bastoncini - Kit 200 bags
+ 200 paper sticks

abbinabile con - can be
combined with **KS30**



T113

mm 50 h

4 modelli - 10 fogli
200 impronte
4 designs - 10 sheets
200 indents

Kit 200 sacchetti + 200
bastoncini - Kit 200 bags
+ 200 paper sticks

abbinabile con - can be
combined with **KS30**



Christmas





Stampi termoformati Thermoformed moulds

NEW

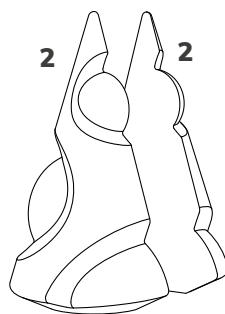

KT178
Merlin

Ø mm 120x200 h
~ 180 g

PACKAGING: KS26

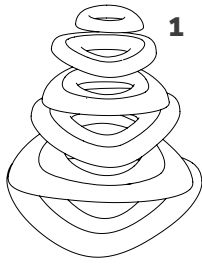
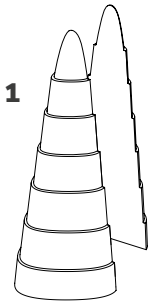

KT176
Saturno

Ø mm 165x195 h
~ 450 g





KT136
Wave

Ø mm 160x200 h
~ 260 g

PACKAGING: KS32

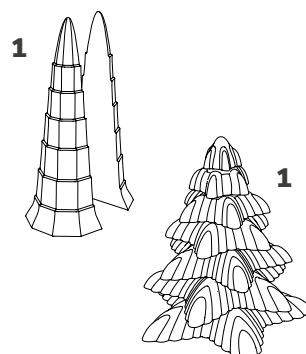

KT177
Fringe

Ø mm 135x150 h
~ 350 g

PACKAGING: KS32

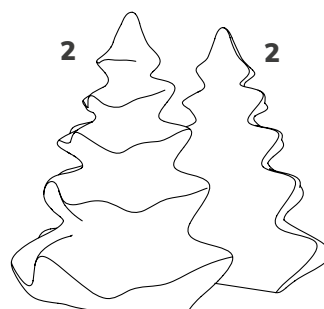

KT163
Tutu

Ø mm 140x150 h
~ 200 g

PACKAGING: KS32

KT164
Tutu

Ø mm 170x200 h
~ 320 g

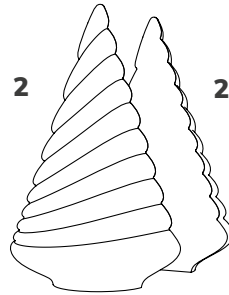

KT150
Soft

Ø mm 125x195 h
~ 200 g

PACKAGING: KS26

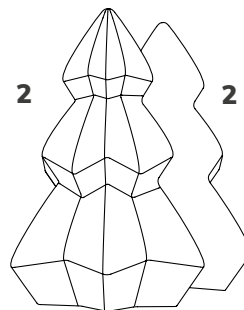

KT151
Crystal

Ø mm 145x200 h
~ 180 g

PACKAGING: KS32

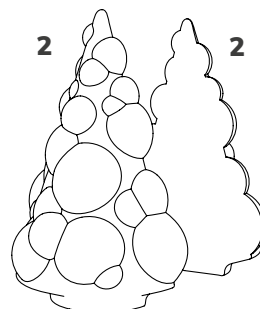

KT175
Ampolla

Ø mm 135x200 h
~ 200 g

PACKAGING: KS32

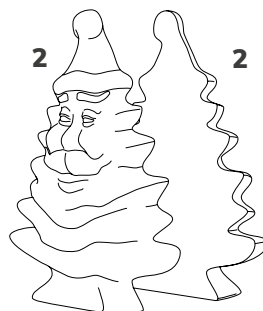

KT135
Albero Animato

mm 160x75x200 h
~ 250 g

PACKAGING: KS26

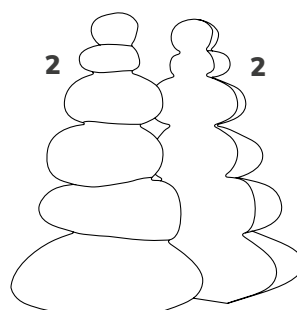

KT137
Zen

Ø mm 160x200 h
~ 290 g

PACKAGING: KS32

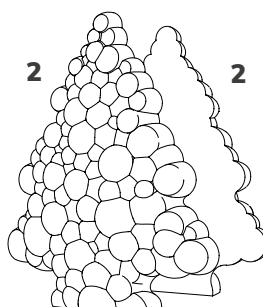

KT152
Bolla

mm 160x65x200 h
~ 250 g

PACKAGING: KS26

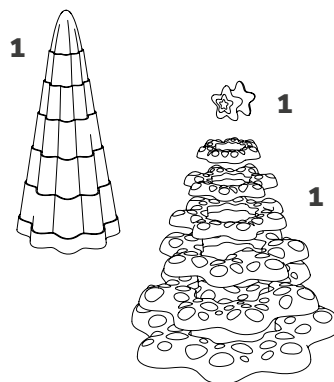

KT162
Ring

Ø mm 160x200 h
~ 500 g

PACKAGING: KS32

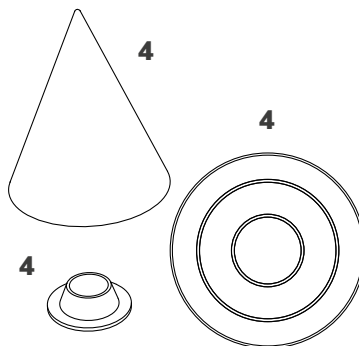

KT16
Albero a cono

Ø mm 110x160 h
~ 250 g

PACKAGING: KS26

KT20
Albero a cono

Ø mm 140x210 h
~ 350 g

PACKAGING: KS32

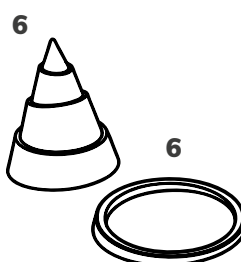

KT60
Kit Alberelli

Ø mm 75x90 h
~ 350 g

PACKAGING: KS26

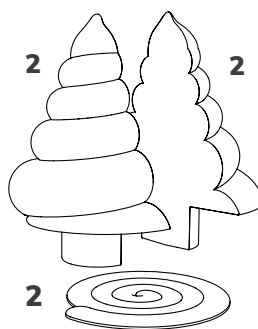

KT125
Spirale

Ø mm 160x210 h
~ 350 g

PACKAGING: KS32

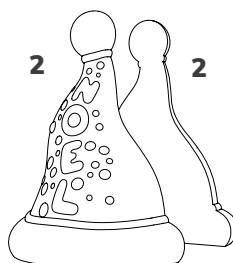

KT153
Noel

Ø mm 130x170 h
~ 180 g

PACKAGING: KS26

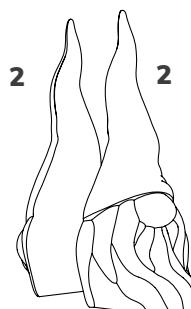

KT165
Gnomo

mm 115x85x200 h
~ 200 g

PACKAGING: KS26

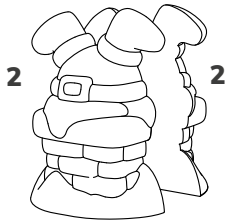

KT179
Santa Chimney

NEW

Ø mm 125x170 h
~ 380 g

PACKAGING: KS26

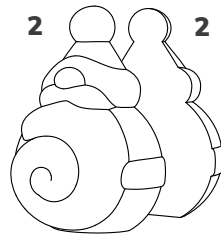

KT180
Santa Twist

NEW

Ø mm 140x180 h
~ 280 g

PACKAGING: KS32



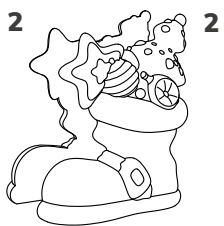

KT181
Santa Boot

NEW

mm 160x80x180 h
~ 390 g

PACKAGING: KS26



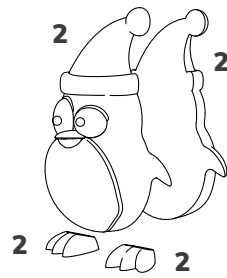

KT120
Pinguino

mm 130x105x170 h
~ 250 g

PACKAGING: KS26

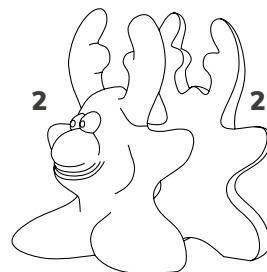

KT133
Renna

mm 145x90x175 h
~ 200 g

PACKAGING: KS26

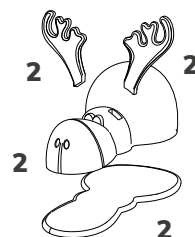

KT86
Rudolph

mm 195x100x100 h
~ 235 g

PACKAGING: KS26

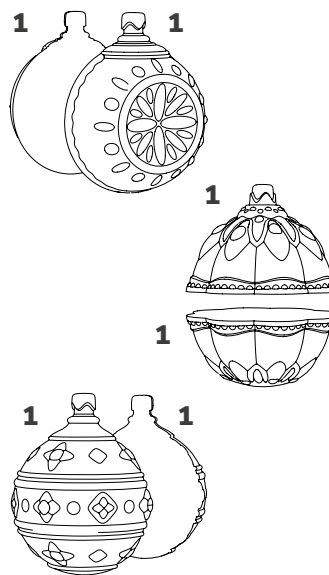

KT149
Xmas Balls

mm 100x75x120 h
 Ø mm105x120 h
 Ø mm100x120 h
 ~ 90 g cad./ each

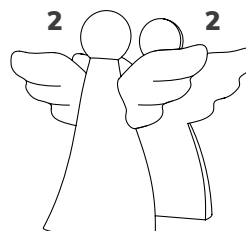

KT148
Angelo

mm 155x75x150 h
 ~ 150 g

PACKAGING: KS26

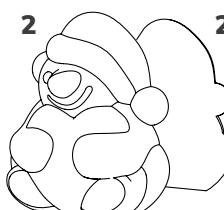

KT166
Teddy

mm 120x115x140 h
 ~ 250 g

PACKAGING: KS26

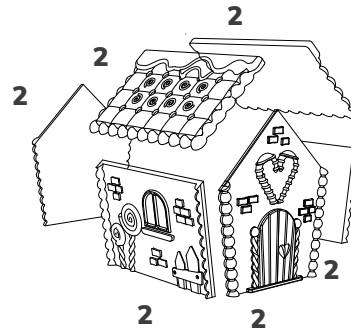

KT126
Casetta

mm 145x135x145 h
~ 400 g

PACKAGING: KS32

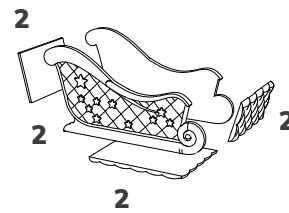

KT127
Slitta

mm 180x100x90 h
~ 200 g

PACKAGING: KS26

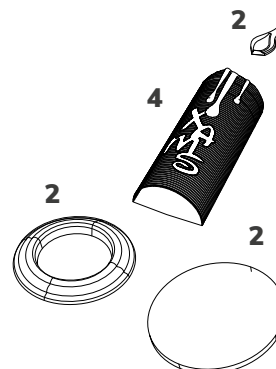

KT87
Candela

Ø mm 110x200 h
~ 215 g

PACKAGING: KS26

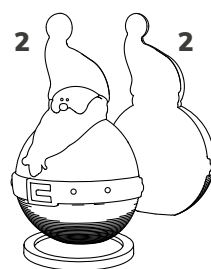

KT122
Babbo

Ø mm 105x170 h
~ 200 g

PACKAGING: KS26

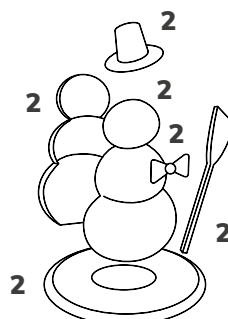

KT22
Pupazzo di neve

Ø mm 130x200 h
~ 300 g

PACKAGING: KS26

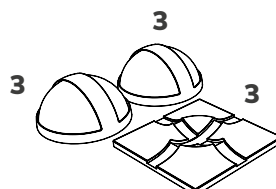

KT61
Palla di Natale

Ø mm 75x85 h
~ 100 g



Stampi termoformati serigrafati Silkscreened thermoformed moulds

Misura foglio: mm 340x265
Il numero di impronte si intende per scatola

Sheet size: mm 340x265
The number of indents is per box



T854

NEW

mm 40 h
24 modelli
4 colori
10 fogli
480 impronte
24 designs
4 colours
10 sheets
480 indents



T855

NEW

mm 50 h
18 modelli
3 colori
10 fogli
360 impronte
18 designs
3 colours
10 sheets
360 indents



T826

mm 50 h
3 modelli
10 fogli
300 impronte
3 designs
10 sheets
300 indents



T827

mm 60 h
4 modelli
10 fogli
240 impronte
4 designs
10 sheets
240 indents



T835

mm 60 h
3 modelli
10 fogli
200 impronte
3 designs
10 sheets
200 indents



T836

mm 35 h
5 modelli
10 fogli
350 impronte
5 designs
10 sheets
350 indents



T837

mm 55 h
 3 modelli
 10 fogli
 240 impronte
 3 designs
 10 sheets
 240 indents



T838

mm 55 h
 2 modelli
 10 fogli
 240 impronte
 2 designs
 10 sheets
 240 indents



T845

mm 40 h
 3 modelli
 10 fogli
 480 impronte
 3 designs
 10 sheets
 480 indents



T846

mm 40 h
 3 modelli
 10 fogli
 480 impronte
 3 designs
 10 sheets
 480 indents



T847

mm 40 h
 3 modelli
 10 fogli
 480 impronte
 3 designs
 10 sheets
 480 indents



T829

mm 60 h
 3 modelli
 10 fogli
 280 impronte
 3 designs
 10 sheets
 280 indents



T822

mm 30 h
 5 modelli
 10 fogli
 200 impronte
 5 designs
 10 sheets
 200 indents



T287

mm 50 h
 5 modelli
 10 fogli
 300 impronte
 5 designs
 10 sheets
 300 indents





T235

mm 48 h

1 modello
10 fogli
360 impronte

1 design
10 sheets
360 indents



T502

mm 53 h

1 modello
10 fogli
300 impronte

1 design
10 sheets
300 indents



T260

mm 62 h

1 modello
10 fogli
300 impronte

1 design
10 sheets
300 indents



T234

mm 42 h

1 modello
10 fogli
800 impronte

1 design
10 sheets
800 indents



T834

mm 70 h - mm 50 h

3 modelli
10 fogli
420 impronte

3 designs
10 sheets
420 indents



T290

mm 68 h

1 modello
10 fogli
400 impronte

1 design
10 sheets
400 indents



T918

mm 60 h

3 modelli
10 fogli
320 impronte

3 designs
10 sheets
320 indents



T828

mm 52 h

4 modelli
10 fogli
400 impronte

4 designs
10 sheets
400 indents





T108

mm 40 h
 4 modelli
 10 fogli
 480 impronte
 4 designs
 10 sheets
 480 indents



T997

mm 40 h
 4 modelli
 10 fogli
 480 impronte
 4 designs
 10 sheets
 480 indents



T231

Ø mm 30
 9 modelli
 10 fogli
 630 mezze sfere
 9 designs
 10 sheets
 630 hemispheres



T231/A

Ø mm 30
 9 modelli
 10 fogli
 630 mezze sfere
 9 designs
 10 sheets
 630 hemispheres



T981

Ø mm 70
 2 modelli
 10 fogli
 120 impronte
 2 designs
 10 sheets
 120 hemispheres



T983

Ø mm 40
 2 modelli
 10 fogli
 480 impronte
 2 designs
 10 sheets
 480 hemispheres



T998

Ø mm 70
 4 modelli
 10 fogli
 120 impronte
 4 designs
 10 sheets
 120 hemispheres



T100

Ø mm 30
 9 modelli
 10 fogli
 630 impronte
 9 designs
 10 sheets
 630 hemispheres





T104

mm 50 h

5 modelli - 10 fogli - 200 impronte
5 designs - 10 sheets - 200 indents

Il kit include 200 sacchetti + 200 bastoncini
The kit includes 200 bags + 200 paper sticks

abbinabile con - can be combined with:



KS30

bastoncini 200 pezzi - sticks 200 pcs



T704

mm 50 h

6 modelli - 10 fogli - 200 impronte
6 designs - 10 sheets - 200 indents

Il kit include 200 sacchetti + 200 bastoncini
The kit includes 200 bags + 200 paper sticks

abbinabile con - can be combined with:



KS30

bastoncini 200 pezzi - sticks 200 pcs



CD6

Ø mm 120

4 modelli
10 fogli
40 impronte

4 designs
10 sheets
40 indents



PZ11

mm 190x130

Il kit include 10 puzzle
10 fogli in PVC - 10 buste

Kit contains 10 puzzles
10 PVC sheets - 10 bags



Serigrafie - Silkscreens

Dimensione fogli 340x265 mm - Sheet dimensions 340x265 mm

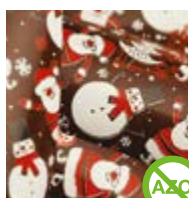

SD87

bianco rosso nero - white red black



30 fogli per confezione
30 sheets per box

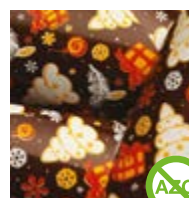

SD88

rosso giallo bianco - red yellow white



30 fogli per confezione
30 sheets per box



Fashion & Style



Stampi termoformati Thermoformed moulds

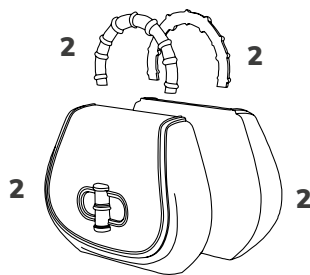

KT145
Bamboo

mm 150x70x165 h
~ 250 g



Stampi magnetici in policarbonato Magnetic polycarbonate moulds



SH02
Zeppa

mm 170x70x155 h
~ 160 g



Stampi termoformati Thermoformed moulds

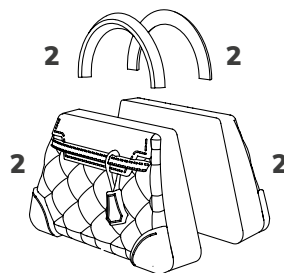

KT123
Borsetta

mm 165x80x150 h
~ 220 g

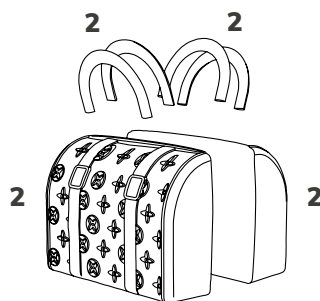

KT144
Bauletto

mm 155x90x160 h
~ 300 g

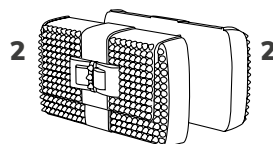

KT146
Pochette

mm 155x70x90 h
~ 170 g



Stampi magnetici in polycarbonato
Magnetic polycarbonate moulds

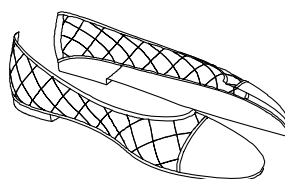

SH01
 Ballerina

mm 185x65x50 h
 ~ 90 g



SCARPADECOLTE
 Scarpetta

mm 150x70x120 h
 ~ 150 g

Sign your creation





Il modo migliore di metterci la firma, la tua. La linea "Sign Your Creation" di Pavoni Italia permette di apporre il tuo logo o firma su tanti prodotti diversi: placchette in cioccolato extrasottili, fogli termoformati, vuoti o pre-riempiti, fogli serigrafati, da utilizzare con o senza chablon. Inviaci il tuo design, elaboreremo ciò che hai inviato e ti invieremo delle proposte.

- Crea il tuo logo
- Inviato a info@pavonitalia.com
- Personalizza placchette in cioccolato e fogli termoformati, vuoti o riempiti, o serigrafati con e senza chablon

The best way to make it your own? Put your name on it! The "Sign Your Creation" line by Pavoni Italia allows you to put your logo or signature on many different products: extra-thin chocolate plaques, thermoformed sheets – empty or pre-filled – and silkscreened sheets, for use with or without a chablon stencil. Send us your design, we will work on what you have sent and we will send you some proposals.

- Create your logo
- Send it to info@pavonitalia.com
- Customise chocolate plaques and thermoformed sheets – empty or filled – or silkscreened sheets with or without a chablon stencil



Placchette in cioccolato extrasottili *Extra-thin chocolate plaques*

Un prodotto d'eccellenza, pronto all'uso e dallo spessore estremamente sottile. Preparate con cioccolato di alta qualità, creano un feeling perfettamente "fatto a mano", per un binomio ideale fra artigianalità ed eleganza.

- **LOGO:** da 1 a 4 colori
- **QUANTITÀ MINIMA:** 10 confezioni (5 fogli a confezione)
- **CIOCCOLATO:** bianco, latte o fondente.

A first-class product, ready to use and extremely thin. Prepared with high quality chocolate, they add a perfect "handmade" touch, for an ideal combination of craftsmanship and elegance.

- **LOGO:** from 1 to 4 colours
- **MINIMUM QUANTITY:** 10 boxes (5 sheets per box)
- **CHOCOLATE:** white, milk, dark.

Tondo - Round

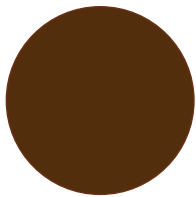
	CODE	DIMENSION (mm)	PEZZI PER SCATOLA PCS PER BOX
	P203	Ø 10	760
	P216	Ø 18	560
	P110	Ø 20	450
	P205	Ø 25	275
	P418	Ø 30	210
	P204	Ø 35	180
	P417	Ø 40	160
	P157	Ø 45	105
	P078	Ø 50	105

Ovale - Oval

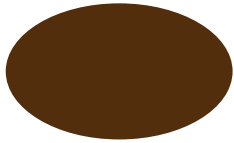
	CODE	DIMENSION (mm)	PEZZI PER SCATOLA PCS PER BOX
	P109	25x15	520
	P150	30x20	300
	P002/335	42x25	200
	P332	30x40	190
	P206	50x15	240
	P397	72x25	125



Quadrato - Square

	CODE	DIMENSION (mm)	PEZZI PER SCATOLA PCS PER BOX
	P170	13x13	1485
	P096	15x15	1250
	P004/105	20x20	630
	P041/136	25x25	450
	P005/065	30x30	300
	P012/365	37x37	180
	P073	40x40	135
	P021/127	50x50	105

Rettangolare - Rectangular

	CODE	DIMENSION (mm)	PEZZI PER SCATOLA PCS PER BOX
	P168	20x8	1620
	P219	35x9	450
	P468	60x10	450
	P428	120x12	360
	P020	30x15	600
	P057/131	70x15	250
	P156	40x16	405
	P348	25x20	540
	P037	55x20	210
	P003/108	37x24	300
	P074	50x25	210
	P056	70x25	150
	P339	35x30	250
	P030	55x30	150
	P023/135	50x36	150
P075	60x40	90	

Cuore - Heart

	CODE	DIMENSION (mm)	PEZZI PER SCATOLA PCS PER BOX
	P048	32x29	200
	P115	34x33	200
	P011	30x30	300
	P012	37,5x37,5	400
	P053	50x50	105



Blister

Tante forme e dimensioni dei termoformati vuoti o pre-riempiti con cioccolato fondente o bianco, completamente personalizzabili con il tuo design.

BLISTER VUOTI

- **LOGO:** da 1 a 4 colori
- **QUANTITÀ MINIMA:** 2 confezioni
(50 fogli a confezione)

BLISTER PRE-RIEMPITI

- **LOGO:** da 1 a 4 colori
- **QUANTITÀ MINIMA:** 10 confezioni
(5 fogli a confezione)
- **CIOCCOLATO:** bianco o fondente

In many shapes and sizes; empty or pre-filled thermoformed moulds with dark or white chocolate, fully customisable with your own design.

EMPTY BLISTER

- **LOGO:** from 1 to 4 colours
- **MINIMUM QUANTITY:** 2 boxes
(50 sheets per box)

PRE-FILLED BLISTER

- **LOGO:** from 1 to 4 colours
- **MINIMUM QUANTITY:** 10 boxes
(5 sheets per box)
- **CHOCOLATE** white or dark

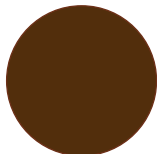

Tondo - Round

	CODE	DIMENSION (mm)	IMPRONTE PER FOGLIO - INDENTS PER SHEET	
	B181	Ø 24	120	senza bordo without frame
	B139	Ø 30	72	senza bordo without frame
	B159	Ø 40	48	senza bordo without frame

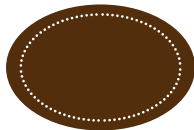

Ovale - Oval

	CODE	DIMENSION (mm)	IMPRONTE PER FOGLIO INDENTS PER SHEET	
	B161	33x22	90	senza bordo without border
	B162	40x25	72	senza bordo without frame
	B167	47x24	70	senza bordo without frame
	B134	57x35	36	senza bordo without frame
	BR148	33x22	90	con bordo with frame
	BR108	40x25	72	con bordo with frame
	BR109	57x35	36	con bordo with frame

Quadrato - Square

	CODE	DIMENSION (mm)	IMPRONTE PER FOGLIO - INDENTS PER SHEET	
	B707	20x20	192	senza bordo without frame
	B204	30x30	72	senza bordo without frame
	B705	32x32	80	senza bordo without frame
	BR147	40x40	48	con bordo with frame

Rettangolare - Rectangular

	CODE	DIMENSION (mm)	IMPRONTE PER FOGLIO - INDENTS PER SHEET	
	B702	60x8	120	senza bordo without frame
	B197	60x15	84	senza bordo without frame
	B163	55x30	36	senza bordo without frame
	BR149	55x30	36	con bordo with frame

Cuore - Heart

	CODE	DIMENSION (mm)	IMPRONTE PER FOGLIO - INDENTS PER SHEET	
	BR102	33x32	54	con bordo with frame

How to use





Fogli serigrafati "Decocioc" Silkscreened sheets "Decocioc"

Il tuo logo e le tue idee, esattamente come le desideri. I fogli serigrafati Decocioc possono essere personalizzati con il tuo marchio o design in ordine sparso o prespaziato, in tanti chablon dalle forme diverse.

- **SERIGRAFIE:** da 1 a 4 colori
- **QUANTITÀ MINIMA:** 5 confezioni, totale 250 fogli (50 fogli a scatola)
- **MISURA FOGLIO:** mm 340x265

Your logo, your ideas, exactly as you want them. Decocioc silkscreened sheets can be customised with your brand or design in a scattered or pre-spaced order, with a variety of chablon stencil shapes.

- **SILKSCREENED SHEETS:** from 1 to 4 colours
- **MINIMUM QUANTITY:** 5 boxes, total 250 sheets (50 sheets per box)
- **SHEET SIZE:** mm 340x265



Fogli serigrafati con marchio in ordine sparso.
Silkscreened sheets with logo in random order.







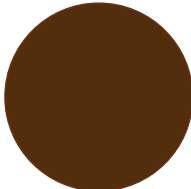

Fogli serigrafati con marchio prespaziato da utilizzarsi con chablon - Silkscreened sheets with pre-spaced logo to be used with chablon.

Chablon per fogli serigrafati Chablon for silkscreened sheets

Tondi, quadrati, rettangolari, triangolari, a cuore, ellittici. Scegli fra le numerose forme e dimensioni di chablon (mm 340x280).

Round, square, rectangular, triangular, heart-shaped, oval. Choose from a wide range of chablon shapes and sizes (mm 340x280).

	CODE	DIMENSION (mm)	IMPRONTE PER CHABLON INDENTS PER CHABLON
	D25T	Ø 25	56
	D3T	Ø 30	48
	D35T	Ø 35	35
	D4T	Ø 40	30
	D40-O	40x24	36
	D45-O	45x27	30
	D3C	Ø 30	48
	D35C	Ø 35	35
	D25QR	25x25	56
	D4QR	40x40	30
	D51R	52x12	65
	D52R	52x26	35
	D38TR	38x38	66

Choco Bar Moulds





Vincent Vallée x Choco Bar Moulds

Il cioccolato è passione pura. I nuovi stampi per tavolette di cioccolato, sviluppati dal World Chocolate Master 2015 Vincent Vallée insieme al team di ricerca Pavoni Italia, hanno nella precisa essenzialità il loro cuore. Tre design unici e coraggiosi, per chi ama essere avanti al proprio tempo.

Chocolate is pure passion. The new moulds for chocolate bars - developed by 2015 World Chocolate Master Vincent Vallée in collaboration with Pavoni Italia R&D team - have their core in the accurate essentiality. Three unique and bold designs, for those who aim to be ahead.

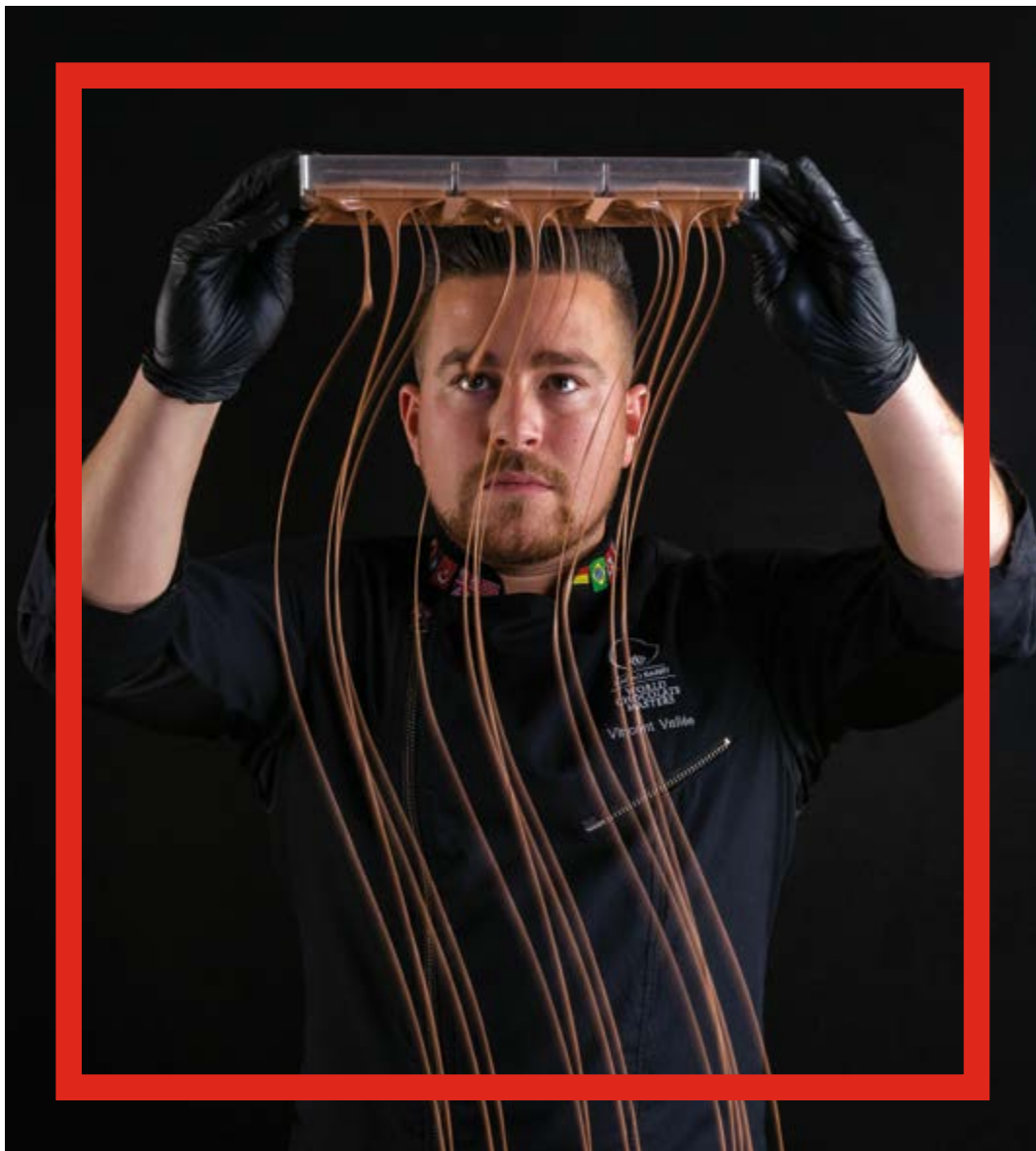



PC5004
Fragment
by Vincent Vallée

NEW

mm 155x77x10 h
~ 100 g

3 impronte - indents

Dim stampo - Mould size:
mm 275x175





PC5005
Edelweiss
by Vincent Vallée

NEW

mm 155x77x10 h
~ 100 g

3 impronte - indents

Dim stampo - Mould size:
mm 275x175



**PC5006****Pavé**

by Vincent Vallée

NEWmm 155x78x10 h
~ 100 g

3 impronte - indents

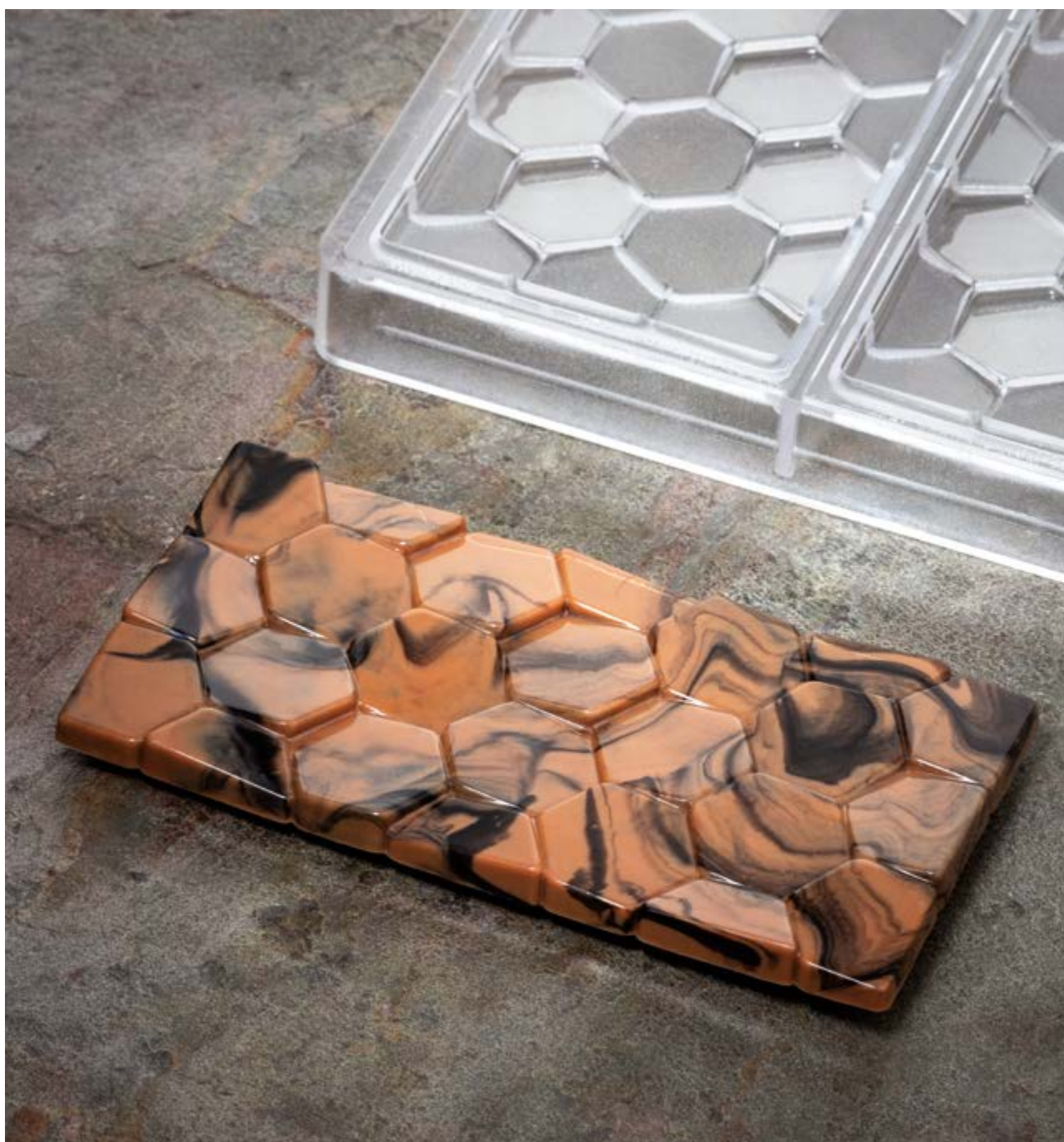
Dim stampo - Mould size:
mm 275x175

Fabrizio Fiorani x Choco Bar Moulds



PC5001
Sparkling
by Fabrizio Fiorani

NEW

mm 150x77x12 h
~ 100 g

3 impronte - indents

Dim stampo - Mould size:
mm 275x175



Guarda il video dedicato a **Choco Bar Moulds by Fabrizio Fiorani** sul canale Youtube di Pavoni Italia
Watch the video **Choco Bar Moulds by Fabrizio Fiorani** on Pavoni Italia's Youtube channel

**PC5002****Crush**

by Fabrizio Fiorani

NEW

mm 155x77x10 h

~ 100 g

3 impronte - indents

Dim stampo - Mould size:
mm 275x175



PC5003

Ola

by Fabrizio Fiorani

NEW

mm 155x77x10 h
~ 100 g

3 impronte - indents

Dim stampo - Mould size:
mm 275x175



Antonio Bachour x Choco Bar Moulds



PC5000

Lovely

by Antonio Bachour

NEW

mm 150x76x10 h
~ 100 g

3 impronte - indents

Dim stampo - Mould size:
mm 275x175



Bonbons





Antonio Bachour x Praline Moulds

L'arte della pralina. Bonbons è la linea di stampi per praline nata dalla fantasia di Antonio Bachour e dalla progettazione Pavoni Italia. Linee morbide, giocose, dal gusto pop: un tocco di novità da interpretare in ventuno inimitabili creazioni.

The art of praline. Bonbons is a line of praline moulds, fruit of the imagination of Antonio Bachour and the design of Pavoni Italia. Soft, playful lines with a note of pop: a fresh twist to be interpreted in twenty-one inimitable creations.

Dimensione stampo - Mould size: mm 275x135

21 pezzi per stampo - 21 pcs per mould

Disponibile anche BPA free - Available also BPA free



PC38

mm 44x24x20 h
+/- 10 g



PC39

mm 38x26x18 h
+/- 10 g



PC40

mm 33x28x20 h
+/- 10 g



PC41

mm 43x25x17 h
+/- 10 g



PC42

mm 41x24x20 h
+/- 10 g



PC43

mm 36x25x20 h
+/- 10 g



PC44

mm 35x24x17 h
+/- 10 g



PC45

Ø mm 30x16 h
+/- 10 g



PC46

mm 40x18x16 h
+/- 10 g

**PC47**

mm 27x27x15 h
+/- 10 g

**PC48**

mm 42x21x18 h
+/- 10 g

**PC56**

mm 31x26x16 h
+/- 10 g

**PC57**

mm 33x26x16 h
+/- 10 g

**PC58**

mm 33x29x17 h
+/- 10 g

**PC59**

mm 26x26x16 h
+/- 10 g

**PC60**

mm 33x22x16 h
+/- 10 g

**PC61**

mm 33x27x17 h
+/- 10 g

**PC62**

mm 34x22x16 h
+/- 10 g

**PC63**

mm 30x29x17 h
+/- 10 g

**PC64**

mm 26x26x16 h
+/- 10 g

**PC65**

mm 28x28x18 h
+/- 10 g



Guarda il video dedicato a **Bonbons** sul canale Youtube di Pavoni Italia
Watch the video "**Bonbons**" on Pavoni Italia's Youtube channel

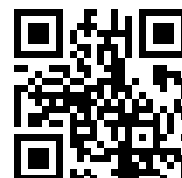

Iconic





Fabrizio Fiorani x Praline Moulds

La prima pralina col vuoto al centro. Iconic è un must. Un'idea che nasce dal desiderio di rompere gli schemi creando qualcosa di unico, tra cinque forme geometriche pure e l'innovazione tecnica del foro passante svasato, dal team di ricerca Pavoni Italia.

The first praline with a hole through its centre. Iconic is a must. An idea that stems from the desire to break the patterns by creating something unique, among five pure geometric shapes and the technical innovation of the countersunk through-hole by the Pavoni Italia research and development team.



Dimensione stampo - Mould size: mm 275x135

21 pezzi per stampo - 21 pcs per mould

Disponibile anche BPA free - Available also BPA free

**PC49**

mm 33x30x15 h
+/- 10 g

**PC51**

mm 26x26x16 h
+/- 10 g

**PC52**

mm 31x29x16 h
+/- 10 g

**PC53**

Ø mm 28x16 h
+/- 10 g

**PC55**

mm 29x30x16 h
+/- 10 g



Guarda il video dedicato a **Iconic** sul canale Youtube di Pavoni Italia
Watch the video "**Iconic**" on Pavoni Italia's Youtube channel

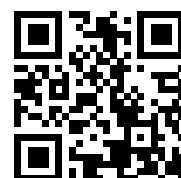

Abyss

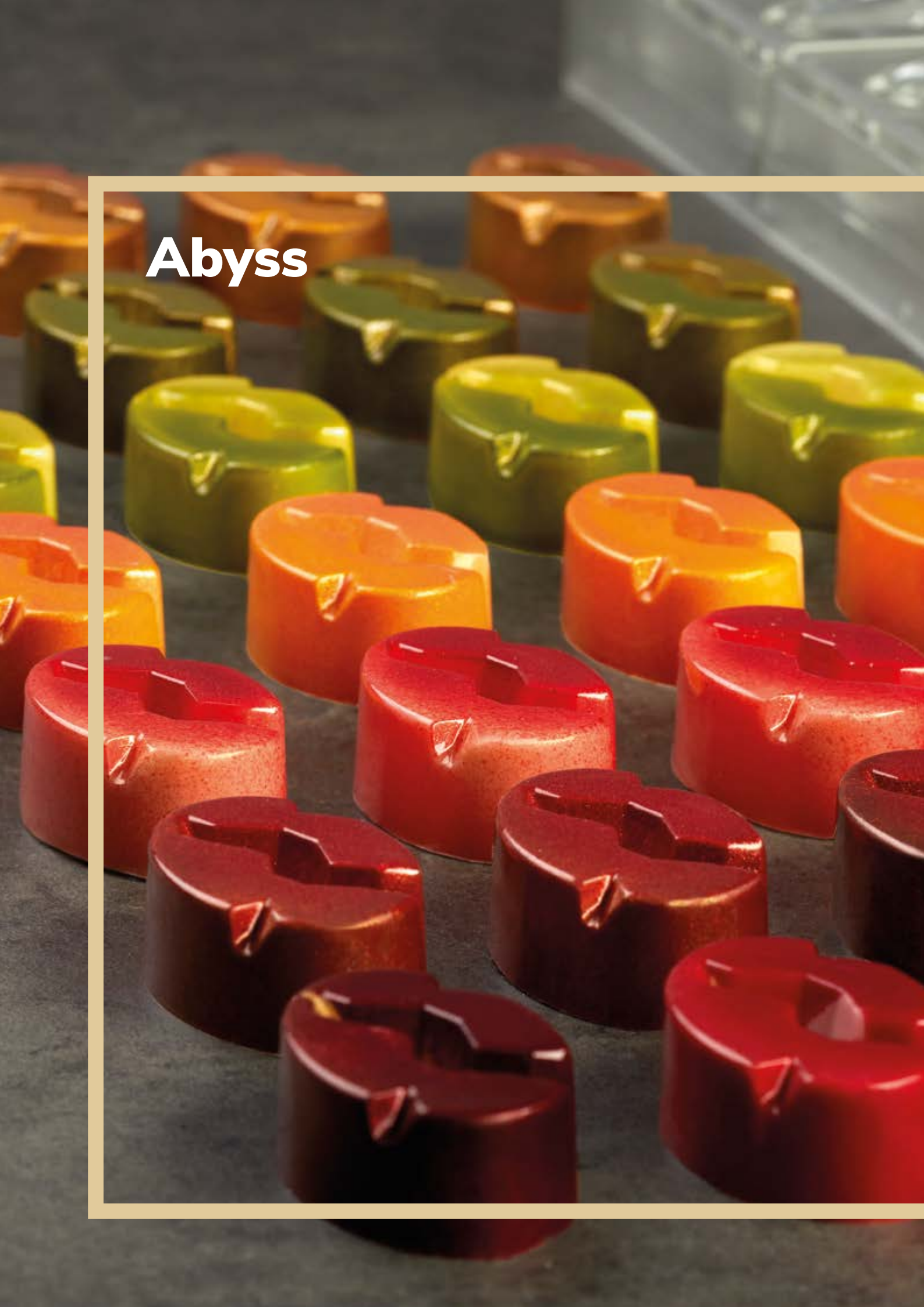



Davide Comaschi x Praline Moulds

Linee e volumi ispirati dalle grandi architetture naturali. Abyss spacca la pralina al centro, tracciando la linea per interpretazioni eleganti e raffinate. La massima armonizzazione fra alta pasticceria e design, in un incontro unico fra il Campione del Mondo Davide Comaschi e Pavoni Italia.

Lines and shapes inspired by the great natural structures. Abyss splits the praline in the centre, tracing the line for elegant and refined expressions. The ultimate balance between haute patisserie and design, in a unique collaboration between the World Champion Davide Comaschi and Pavoni Italia.



Dimensione stampo - Mould size: mm 275x135

18 pezzi per stampo - 18 pcs per mould

Disponibile anche BPA free - Available also BPA free

PC66



mm 31x31x12,5 h
+/- 10 g

designed by
Giuseppe Tortato
ADI DESIGN INDEX 2019



PC67

Ø mm 33x12,5 h
+/- 10 g



PC68

mm 41x24x12,5 h
+/- 10 g



PC69

mm 39x20x12,5 h
+/- 10 g



Guarda il video dedicato a **Abyss** sul canale Youtube di Pavoni Italia
Watch the video "**Abyss**" on Pavoni Italia's Youtube channel

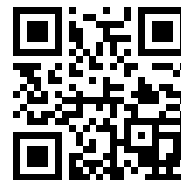

Praline Moulds







Innovation

Dimensione stampo - Mould size: mm 275x135

Disponibile anche BPA free - Available also BPA free



PC36

Ø mm 25x25 h
+/- 10 g
21 pezzi per stampo
21 pcs per mould



PC23

mm 18x18x20 h
+/- 10 g
21 pezzi per stampo
21 pcs per mould
by Davide Comaschi



PC01

mm 14x37x19 h
+/- 10 g
21 pezzi per stampo
21 pcs per mould



PC02

mm 17x37x17 h
+/- 10 g
21 pezzi per stampo
21 pcs per mould



PC03

mm 15x37x15 h
+/- 10 g
21 pezzi per stampo
21 pcs per mould



PC04

mm 15x37x19 h
+/- 10 g
21 pezzi per stampo
21 pcs per mould



PC05

mm 17x37x17 h
+/- 10 g
21 pezzi per stampo
21 pcs per mould



PC06

mm 16x37x16 h
+/- 10 g
21 pezzi per stampo
21 pcs per mould



PC07

mm 17x37x17 h
+/- 10 g
21 pezzi per stampo
21 pcs per mould



PC08

Ø mm 30x18 h
+/- 10 g
21 pezzi per stampo
21 pcs per mould



PC09

Ø mm 30x18 h
+/- 10 g
21 pezzi per stampo
21 pcs per mould



PC10

mm 32x23x19 h
+/- 10 g
21 pezzi per stampo
21 pcs per mould



PC11

Ø mm 30x17 h
+/- 10 g
21 pezzi per stampo
21 pcs per mould



PC12

mm 30x30x18 h
+/- 10 g
21 pezzi per stampo
21 pcs per mould



PC13

mm 22x22x20 h
+/- 10 g
21 pezzi per stampo
21 pcs per mould



PC14

Ø mm 26x16 h
+/- 10 g
21 pezzi per stampo
21 pcs per mould



PC15

mm 26x23x21 h
+/- 10 g
21 pezzi per stampo
21 pcs per mould



PC16

Ø mm 31x20 h
+/- 10 g
21 pezzi per stampo
21 pcs per mould



PC17

mm 30x30x17 h
+/- 10 g
21 pezzi per stampo
21 pcs per mould



PC18

Ø mm 28x17 h
+/- 10 g
21 pezzi per stampo
21 pcs per mould



PC19

mm 22x18x28 h
+/- 10 g
24 pezzi per stampo
24 pcs per mould



PC20

mm 22x21x28 h
+/- 10 g
24 pezzi per stampo
24 pcs per mould



PC21

mm 18x18x28 h
+/- 10 g
24 pezzi per stampo
24 pcs per mould



PC22

Ø mm 21x28 h
+/- 10 g
24 pezzi per stampo
24 pcs per mould



PC37

Ø mm 26x23,5 h
+/- 10 g
21 pezzi per stampo
21 pcs per mould

Heart Design

by Davide Comaschi

3 forme diverse in ogni stampo, per formare 5 cuori completi.

3 different shapes per mould to create 5 whole hearts.

Dimensione stampo - Mould size: mm 275x135

15 pezzi per stampo - 15 pcs per mould

Disponibile anche BPA free - Available also BPA free

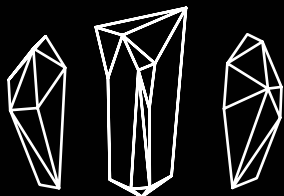

PC50

+/- 13 g



Guarda il video dedicato a **Heart Design** sul canale Youtube di Pavoni Italia
Watch the video "**Heart Design**" on Pavoni Italia's Youtube channel

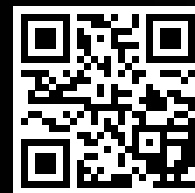



Artisanal

Dimensione stampo - Mould size: mm 275x135

21 pezzi per stampo - 21 pcs per mould

Disponibile anche BPA free - Available also BPA free

Tonde - Round



PC100

Ø mm 28x14 h
+/- 10 g



PC101

Ø mm 28x14 h
+/- 10 g



PC102

Ø mm 28x14 h
+/- 10 g



PC113

Ø mm 28x14 h
+/- 10 g

Rettangolari - Rectangular



PC106

mm 37x16x14 h
+/- 10 g



PC107

mm 37x16x14 h
+/- 10 g



PC108

mm 37x16x14 h
+/- 10 g



PC114

mm 37x16x14 h
+/- 10 g

Ovali - Oval



PC109

mm 37x21x14 h
+/- 10 g



PC110

mm 37x21x14 h
+/- 10 g



PC111

mm 37x21x14 h
+/- 10 g



PC115

mm 37x21x14 h
+/- 10 g

Quadrate - Square



PC103

mm 26x26x13 h
+/- 10 g



PC104

mm 26x26x13 h
+/- 10 g



PC105

mm 26x26x13 h
+/- 10 g



PC112

mm 26x26x13 h
+/- 10 g



Tradition

Dimensione stampo - Mould size: mm 275x175

Disponibile anche BPA free - Available also BPA free

NEW



SP2002S

Ø mm 32x16 h
+/- 10 g
15 pezzi per stampo
15 pcs per mould



SP2251S

Ø mm 50x25 h
+/- 33 g
12 pezzi per stampo
12 pcs per mould



SP2252S

Ø mm 60x30 h
+/- 56 g
8 pezzi per stampo
8 pcs per mould



SP2253S

Ø mm 55x27,5 h
+/- 44 g
6 pezzi per stampo
6 pcs per mould



SP2254S

Ø mm 65x32,5 h
+/- 86 g
6 pezzi per stampo
6 pcs per mould

Dimensione stampo - Mould size: mm 275x135

Disponibile anche BPA free - Available also BPA free



SP1217S

Ø mm 24x12 h
+/- 5 g
24 pezzi per stampo
24 pcs per mould



SP1001S

mm 33x21x16 h
+/- 10 g
21 pezzi per stampo
21 pcs per mould



SP1002S

Ø mm 23x16 h
+/- 8 g
21 pezzi per stampo
21 pcs per mould



SP1003S

mm 35x26x19 h
+/- 12 g
24 pezzi per stampo
24 pcs per mould

**SP1024S**

Ø mm 25x17 h
+/- 8 g
21 pezzi per stampo
21 pcs per mould

**SP1025S**

mm 18x28x16 h
+/- 8 g
24 pezzi per stampo
24 pcs per mould

**SP1032S**

mm 32x21x13 h
+/- 7 g
24 pezzi per stampo
24 pcs per mould

**SP1045S**

mm 28x25x17 h
+/- 11 g
24 pezzi per stampo
24 pcs per mould

**SP1064S**

mm 32x21x14 h
+/- 8 g
24 pezzi per stampo
24 pcs per mould

**SP1082S**

mm 32x19x16 h
+/- 10 g
30 pezzi per stampo
30 pcs per mould

**SP1156S**

mm 30x15x12 h
+/- 6 g
30 pezzi per stampo
30 pcs per mould

**SP1214S**

mm 25x28x15 h
+/- 8 g
24 pezzi per stampo
24 pcs per mould

**SP1219S**

mm 22x18x13 h
+/- 5 g
24 pezzi per stampo
24 pcs per mould

**SP1244S**

mm 32x22x14 h
+/- 10 g
24 pezzi per stampo
24 pcs per mould

**SP1327S**

mm 28x18x13 h
+/- 6 g
24 pezzi per stampo
24 pcs per mould

**SP1334S**

mm 27x16x13 h
+/- 6 g
24 pezzi per stampo
24 pcs per mould



Magnetic

Concepito per la realizzazione di praline stampate con fogli serigrafati.

Designed for the creation of pralines printed with silkscreened sheets.

Dimensione stampo - Mould size: mm 275x135

15 pezzi per stampo - 15 pcs per mould

Disponibile anche BPA free - Available also BPA free



MM11

Ø mm 30
+/- 13 g



MM12

mm 35x30
+/- 15 g



MM13

mm 30x30
+/- 13 g



MM14

Ø mm 30
+/- 10 g

Chocolate Moulds







Stampi termoformati serigrafati

Silkscreened thermoformed moulds

Misura foglio: mm 340x265
Il numero di impronte si intende per scatola

Sheet size: mm 340x265
The number of indents is per box

T858 Evidenziatore - Marker

NEW

lunghezza - length mm 90

1 modello - 3 colori - 10 fogli - 300 impronte
(150 evidenziatori)

1 design - 3 colours - 10 sheets - 300 indents
(150 markers)



T842 Matita - Pencil Size S

lunghezza - length mm 80

1 modello - 6 colori - 9 fogli - 540 impronte
(270 matite)

1 design - 6 colours - 9 sheets - 540 indents
(270 pencils)



T110 Matita - Pencil Size L

lunghezza - length mm 220

1 modello - 6 colori - 12 impronte
(6 matite)

1 design - 6 colours - 12 indents
(6 pencils)





T852

mm 137x67x7 h

60 impronte
60 indents

PACKAGING: KS49



T115

mm 160x120x7 h

40 impronte
40 indents

PACKAGING: KS38



TFOOT-70

Ø mm 70
10 fogli - 120 mezze sfere
10 sheets - 120 hemispheres

TFOOT-30

Ø mm 30
10 fogli - 630 mezze sfere
10 sheets - 630 hemispheres



T114

Ø mm 50
5 modelli - 10 fogli -
200 impronte
5 designs - 10 sheets -
200 indents
Il kit include 200 sacchetti +
200 bastoncini
The kit includes 200 bags +
200 paper sticks

KS30

200 bastoncini - sticks



T706

mm 32x32
1 modello
10 fogli
800 impronte
1 design
10 sheets
800 indents



T709

mm 20x20
6 modelli
10 fogli
1920 impronte
6 designs
10 sheets
1920 indents



T506*

mm 40x30 h
3 modelli
10 fogli
640 impronte
3 designs
10 sheets
640 indents

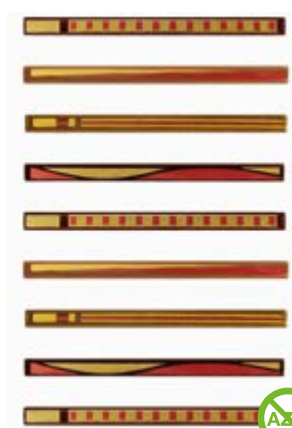

T907

mm 120x8x2 h
4 modelli
10 fogli
560 impronte
4 designs
10 sheets
560 indents



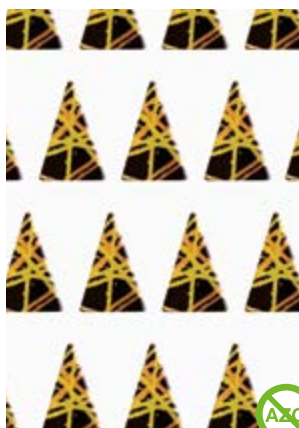

T407

mm 31x47 h

1 modello
10 fogli
960 impronte

1 design
10 sheets
960 indents



T925

mm 31x47 h

1 modello
10 fogli
960 impronte

1 design
10 sheets
960 indents



T401

mm 32x32

1 modello
10 fogli
800 impronte

1 design
10 sheets
800 indents



T705

mm 32x32

1 modello
10 fogli
800 impronte

1 design
10 sheets
800 indents



T405

Ø mm 63 - 45 - 27

1 modello
10 fogli
600 impronte

1 design
10 sheets
600 indents



T406

h mm 76 - 52 - 27

1 modello
10 fogli
480 impronte

1 design
10 sheets
480 indents

**Stampi
termoformati
Thermoformed
moulds**

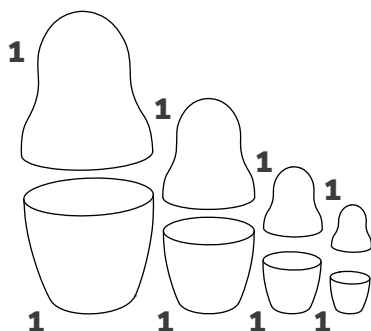

KTMATRIOSKA

Matrioska

by Olga Penioza

4 soggetti - 4 items

mm 200 - 150 - 100 - 50 h





KT159
Semisfere

Kit 3 semisfere
Kit 3 hemispheres
Ø mm 80
Ø mm 100
Ø mm 120

KT160
Semisfere

Kit 3 semisfere
Kit 3 hemispheres
Ø mm 140
Ø mm 160
Ø mm 180

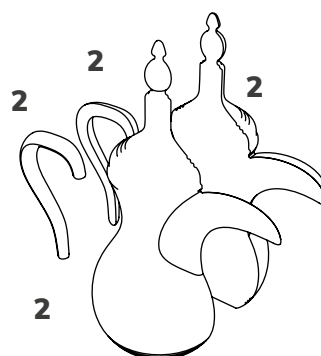

KTDALLAH
Dallah

mm 178x96x230 h
~ 320 g



Delicious Snack

Due stampi in silicone per creare mille snack preziosi e creativi, dolci o salati. Sono concepiti per darti la possibilità di creare ripieni e golose farciture sotto la copertura. Gli stampi sono pensati per essere utilizzati in forno, in frigorifero e abbattitore (resistono a temperature da -40°C a $+250^{\circ}\text{C}$).

Two silicone moulds to create a thousand precious and creative snacks, sweet or savoury. Designed to give you the freedom to create delicious fillings under the coating. The moulds have been developed for use in ovens, refrigerators and blast chillers (withstanding temperatures from -40°C to $+250^{\circ}\text{C}$).

Dimensione stampo - Mould size: mm 285x175

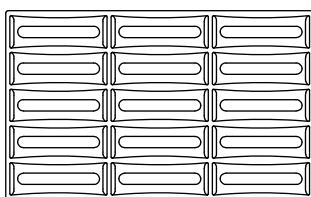

DS01

mm 90x30x19 h
~ 38 ml

15 impronte - indents

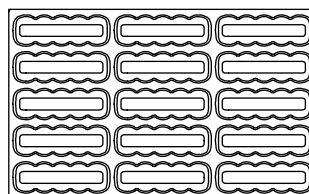

DS02

mm 90x30x19 h
~ 38 ml

15 impronte - indents





Chocoflex

Stampi in silicone pratici, flessibili e resistenti per creazioni dolci o salate. Ideali per realizzare grandi quantità in poco tempo. Resistono da -40°C a + 250°C per uso in forno, frigorifero o abbattitore.

Practical, flexible and durable silicone moulds for sweet or savoury creations. Ideal for making large quantities in a short time. Withstanding temperatures from -40°C to +250°C for use in the oven, refrigerator or blast chiller.

Dimensione stampo - Mould size: mm 290x190

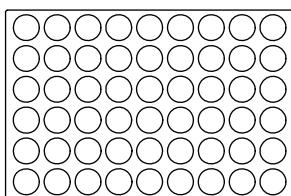

LS01

Ø mm 26x14 h
~ 7,5 ml
54 impronte - indents

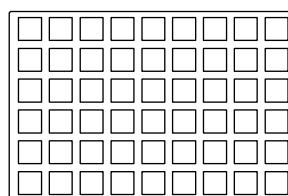

LS02

mm 23x23x14 h
~ 7,5 ml
54 impronte - indents

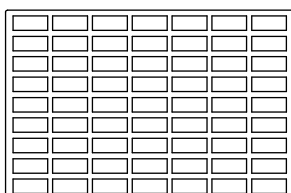

LS03

mm 35x14x14 h
~ 7,5 ml
63 impronte - indents

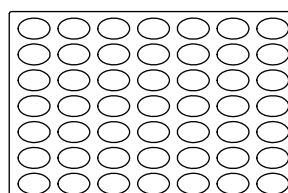

LS04

mm 32x21x14 h
~ 7,5 ml
49 impronte - indents

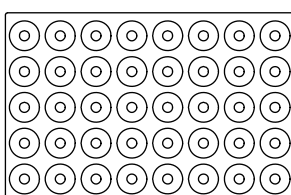

LS06



Ø esterno - external mm 30
Ø interno - internal mm 10
h 12 mm
~ 7,5 ml
40 impronte - indents



Chocolate Decoration



Serigrafie 400x250 mm Silkscreens 400x250 mm

-  Cioccolato fondente - Dark chocolate
-  Cioccolato al latte - Milk chocolate
-  Cioccolato bianco - White chocolate

**SD126**

rosso - red



20 fogli per confezione
20 sheets per box

**SD132**

arancione - orange



20 fogli per confezione
20 sheets per box

**SD129**

verde chiaro - light green



20 fogli per confezione
20 sheets per box

**SD136**

verde bianco - green white

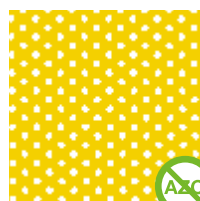

20 fogli per confezione
20 sheets per box

**SD138**

giallo bianco - yellow white



20 fogli per confezione
20 sheets per box

**SD105***

rosso bianco - red white

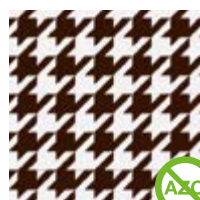

17 fogli per confezione
17 sheets per box

**SD134**

bianco marrone - white brown



20 fogli per confezione
20 sheets per box

**SD127**

fucsia - fuchsia



20 fogli per confezione
20 sheets per box

**SD131**

rosa - pink



20 fogli per confezione
20 sheets per box

**SD137**

fucsia bianco - fuchsia white



20 fogli per confezione
20 sheets per box

**SD115**

rosso bianco - red white



17 fogli per confezione
17 sheets per box

**SD135**

arancione bianco - orange white



20 fogli per confezione
20 sheets per box

**SD133**

rosso bianco - red white



20 fogli per confezione
20 sheets per box

**SD104**

nero bianco - black white



20 fogli per confezione
20 sheets per box



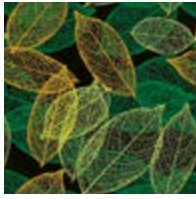

SD118

verde - green



15 fogli per confezione
15 sheets per box

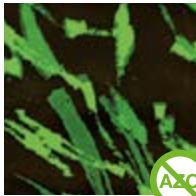

SD96

verde - green



15 fogli per confezione
15 sheets per box



SD92*

oro - gold



17 fogli per confezione
17 sheets per box



SD106

rosso giallo - red yellow



15 fogli per confezione
15 sheets per box

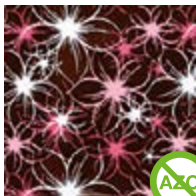

SD94

rosa bianco - pink white



15 fogli per confezione
15 sheets per box



SD95

rosso bianco viola - red white purple



15 fogli per confezione
15 sheets per box



SD99

giallo - yellow



15 fogli per confezione
15 sheets per box



SD100

verde - green



15 fogli per confezione
15 sheets per box

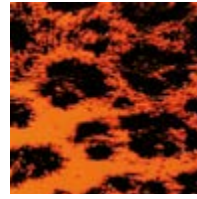

SD102*

leopardato - leopard print



15 fogli per confezione
15 sheets per box

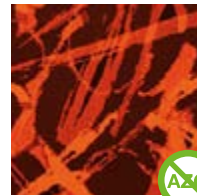

SD101*

arancione - orange



15 fogli per confezione
15 sheets per box



SD97

arancione bianco - orange white



15 fogli per confezione
15 sheets per box



SD107

rosso bianco - red white



15 fogli per confezione
15 sheets per box



SD90

lilla bianco - lilac white



17 fogli per confezione
17 sheets per box



SD109*

rosa - pink



15 fogli per confezione
15 sheets per box

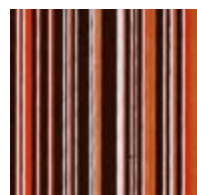

SD110*

arancione - orange



15 fogli per confezione
15 sheets per box



SD111

rosso - red



15 fogli per confezione
15 sheets per box



**SD139**

rosso bianco - red white

20 fogli per confezione
20 sheets per box**SD117**

rosa bianco - pink white

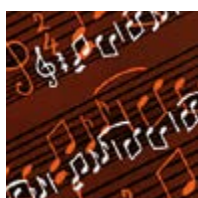
17 fogli per confezione
17 sheets per box**SD103**

arancione bianco nero - orange white black

15 fogli per confezione
15 sheets per box*fino a esaurimento
subject to availability

Serigrafie 340x265 mm Silkscreens 340x265 mm

- Cioccolato fondente - Dark chocolate
- Cioccolato al latte - Milk chocolate
- Cioccolato bianco - White chocolate

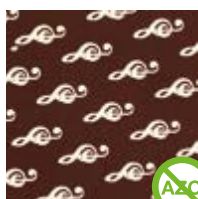
**SD12B**

bianco - white

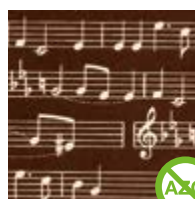
30 fogli per confezione
30 sheets per box**SD19B**

bianco - white

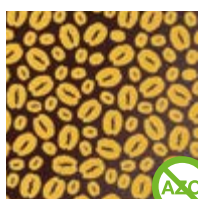
30 fogli per confezione
30 sheets per box**SD15G**

giallo oro - golden yellow

30 fogli per confezione
30 sheets per box**SD15M**

marrone - brown

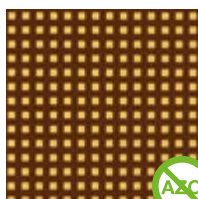
30 fogli per confezione
30 sheets per box**SD36G**

giallo - yellow

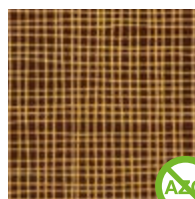
30 fogli per confezione
30 sheets per box**SD20ORO**

oro - gold

30 fogli per confezione
30 sheets per box**SD40G**

giallo oro - golden yellow

30 fogli per confezione
30 sheets per box**SD44G**

giallo oro - golden yellow

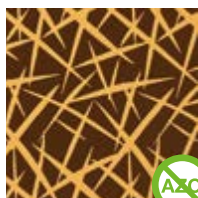
30 fogli per confezione
30 sheets per box**SD39G**

giallo oro - golden yellow

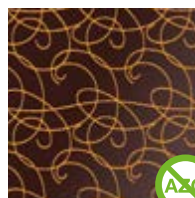
30 fogli per confezione
30 sheets per box**SD41G**

giallo oro - golden yellow

30 fogli per confezione
30 sheets per box



SD38G

giallo oro - golden yellow



30 fogli per confezione
30 sheets per box



SD42R

rosso - red



30 fogli per confezione
30 sheets per box



SD83

lilla viola bianco - lilac purple white



30 fogli per confezione
30 sheets per box

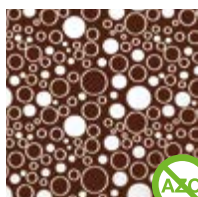

SD45B

bianco - white



30 fogli per confezione
30 sheets per box

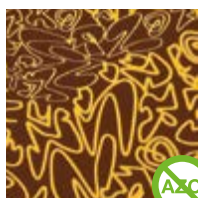

SD56ORO

oro - gold



30 fogli per confezione
30 sheets per box



SD75

arancione rosso fucsia - orange red fuchsia



30 fogli per confezione
30 sheets per box



SD13ORO

oro - gold



30 fogli per confezione
30 sheets per box



SD61

rosso nero - red black



30 fogli per confezione
30 sheets per box

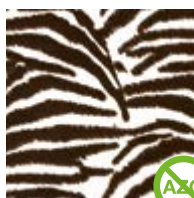

SD73

nero bianco - black white



30 fogli per confezione
30 sheets per box



SD77

bianco - white



30 fogli per confezione
30 sheets per box



SD76

giallo - yellow



30 fogli per confezione
30 sheets per box

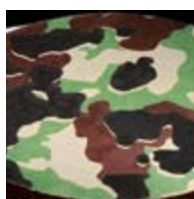

SD120

camouflage by Massimo Bottura



30 fogli per confezione
30 sheets per box

Colori metallizzati
Metallized colours



DB5ORO

oro - gold



30 fogli per confezione
30 sheets per box



DB10

oro - gold



30 fogli per confezione
30 sheets per box



**DB14**

oro - gold

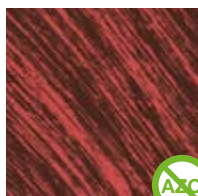
30 fogli per confezione
30 sheets per box**DB18**

rubino - ruby

30 fogli per confezione
30 sheets per box**DB47**

argento - silver

30 fogli per confezione
30 sheets per box**DB39**

nero argento - black silver

30 fogli per confezione
30 sheets per box**DB35**

bianco arancione rame - white orange copper

30 fogli per confezione
30 sheets per box**DB16**

oro rubino - gold ruby

30 fogli per confezione
30 sheets per box**DB33**

rame - copper

30 fogli per confezione
30 sheets per box**DB36**

rubino - ruby

30 fogli per confezione
30 sheets per box**DB41**

nero argento - black silver

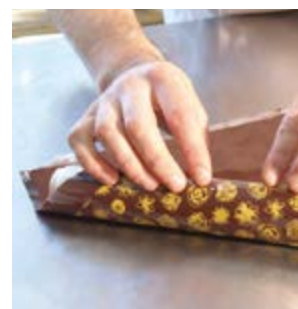
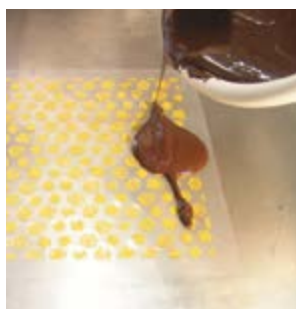
30 fogli per confezione
30 sheets per box**How to use**

Chocofine

Chocofine è una linea di decorazioni in puro cioccolato per conferire un tocco di eleganza alle tue creazioni. Completamente Azo-free, cioè privi di coloranti azoici, le decorazioni Chocofine sono caratterizzate da uno spessore sottile che non appesantisce il dolce ma ne esalta l'estetica.

Chocofine is a line of decorations in pure chocolate to give a gentle touch to your creations. Totally Azo-free (without azoic colours), the Chocofine decorations are featured with a minimum thickness to exalt the aesthetics of your desserts.



CF13

mm 23x60



96 foglie per confezione
96 leaves per box



CF14

mm 23x60



96 foglie per confezione
96 leaves per box



CF16

mm 35x60



72 foglie per confezione
72 leaves per box



CF58

mm 35x58



72 foglie per confezione
72 leaves per box



CF51

mm 35x60



51 foglie per confezione
51 leaves per box

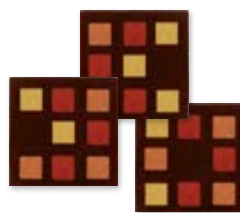

CF63

mm 30x30



120 placchette per confezione
120 plaquettes per box



CF11

mm 30x30



120 placchette per confezione
120 plaquettes per box



CF12

mm 30x30



120 placchette per confezione
120 plaquettes per box



CF52

mm 25x25



270 placchette per confezione
270 plaquettes per box



CF61

Ø mm 30



90 placchette per confezione
90 plaquettes per box

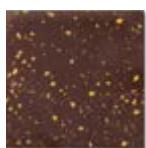

CF05*

mm 30x30



120 placchette per confezione
120 plaquettes per box



CF19*

mm 70x16



180 placchette per confezione
180 plaquettes per box



CF22

mm 70x16



180 placchette per confezione
180 plaquettes per box



CF21

mm 70x16



180 placchette per confezione
180 plaquettes per box



CF36

mm 25



210 placchette per confezione
210 plaquettes per box

*fino a esaurimento
subject to availability



Texture per decoro praline Texture for praline decoration

STRKIT1

32 fogli mm 400x250
4 decorazioni
8 per tipo

32 sheets mm 400x250
4 decorations
8 for each type

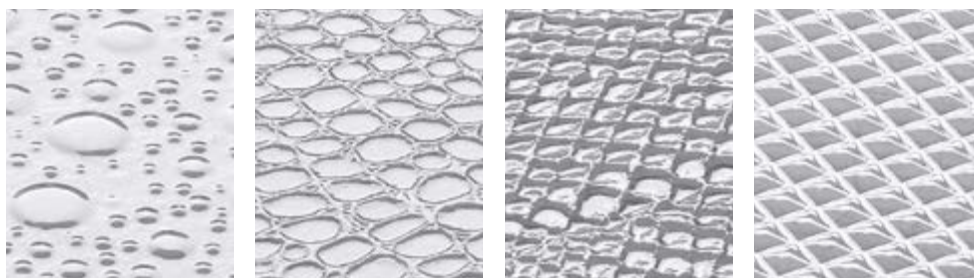

STRKIT2

32 fogli mm 400x250
4 decorazioni
8 per tipo

32 sheets mm 400x250
4 decorations
8 for each type



Chocolate Equipment



FlyChoc

Un progetto realizzato in collaborazione con il Maestro Stefano Laghi e Filippo Re. Dieci attrezzi in acciaio inox pensati per realizzare decorazioni in cioccolato dalle forme e dimensioni diverse. Con FlyChoc piume e foglie si realizzano in modo semplice, veloce e razionale, con un risultato impeccabile.

A project developed in collaboration with Pastry Chefs Stefano Laghi and Filippo Re. Ten stainless steel tools to create chocolate decorations of various shapes and sizes. With FlyChoc feathers and leaves can be created simply, quickly and rationally, with an impeccable result.

Foglia larga - Large leaf



CODE	SIZE	FOGLIA - LEAF DIMENSION (mm)
CH1	S	40x30
CH2	M	50x36
CH3	L	60x44

Foglia - Leaf



CODE	SIZE	FOGLIA - LEAF DIMENSION (mm)
CH4	S	42x22
CH5	M	60x30
CH6	L	80x40

Piuma - Feather



CODE	SIZE	PIUMA - FEATHER DIMENSION (mm)
CH7	S	60x20
CH8	M	80x23
CH9	L	100x24
CH10	XL	120x24

Forchettine pralineria











Praline forks

Forchettine per pralineria con filo in acciaio inox. Acquistabili anche singolarmente, con i relativi codici.

Praline forks with stainless steel wire. Also sold individually, with specific codes.

SFP

Serie completa di 10 pezzi - Complete set of 10 pcs

	CODE		CODE
	SFP1		SFP5
	SFP9		SFP4
	SFP8		SFP3
	SFP6		SFP2
	SFP7		SFP10

Fogli chitarra

Guitar sheets

Lo strumento ideale per la creazione di decorazioni in cioccolato. Molto versatili per la lavorazione del cioccolato, permettono di ottenere una finitura liscia e lucida e garantiscono il distacco immediato delle realizzazioni. Possono essere utilizzati anche per separare le preparazioni da stoccare in abbattitore, al fine di non far attaccare fra di loro i prodotti.

The perfect tool for creating chocolate decorations. Very versatile for working with chocolate, they allow a smooth glossy finish and guarantee immediate detachment of creations. They can also be used to separate desserts to be stored in a blast chiller to prevent products from sticking.

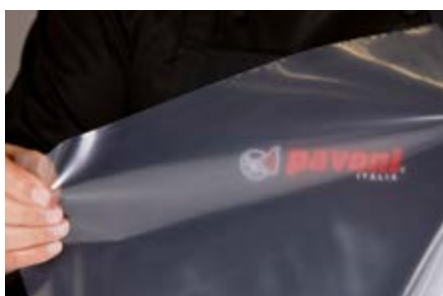

CODE	DIMENSION (mm)	SPESSORE THICKNESS (µm)	PCS PER BOX
FCH34	390x390	100	100 (25 pcs risma - reams)
FCH64	590x390	100	100 (25 pcs risma - reams)

Materiale LDPE - LDPE Material

**PAS
TRY**



Silicone

Il silicone in pasticceria

Nella realizzazione dei prodotti in silicone utilizziamo sempre ed esclusivamente silicone platinico al 100%, secondo le normative UE. Il platino inserito nella materia prima rende il silicone di qualità eccellente, idoneo al contatto con alimenti, atossico, inodore e insapore e sicuro anche a temperature molto elevate. È una scelta che permette di mantenere altissima la performance dei prodotti e che garantisce ai nostri clienti articoli sicuri e resistenti. Gli stampi Pavoni Italia sono innovativi, flessibili e antiaderenti: riproducono fedelmente ogni dettaglio dello stampo, per creare realistiche e incredibili ricette dal particolare effetto 3D!

Silicone in pastry

When manufacturing silicone products we always and exclusively use 100% platinum silicone, in accordance with EU regulations. The platinum inserted in the raw material makes the silicone a product of extremely high quality, suitable for contact with food, non-toxic, odourless and tasteless and safe even at very high temperatures. A choice that ensures the highest product performance, guaranteeing our customers with safe and durable items. Pavoni Italia moulds are innovative, flexible and non-stick: they faithfully reproduce every detail of the mould, to create realistic and incredible recipes with a distinctive 3D effect!

I suoi vantaggi - Advantages



Atossico, inodore e insapore
Non-toxic, odourless and tasteless



Flessibile e salvaspazio
Flexible and space-saving



Infrangibile e a lunga durata
Unbreakable and long-lasting



Resistente da -40°C a +250°C
Withstands -40°C to +250°C



Passa da abbattitore a forno senza attese e viceversa
Switches between blast chiller and oven and vice versa



Lavabile in lavastoviglie
Dishwasher safe

Consigli - Tips

- Lava i tuoi stampi in lavastoviglie senza utilizzare prodotti abrasivi o detergenti particolarmente aggressivi.
Wash your moulds in the dishwasher without using abrasive products or particularly aggressive detergents.
- Non usare coltelli a contatto con lo stampo.
Do not use knives in contact with the mould.
- Non posizionare lo stampo su fonti di calore dirette (fuoco, grill, vetroceramica e piastra elettrica).
Do not place the mould on direct heat sources (fire, grill, ceramic glass or electric plate).
- Non utilizzare la funzione CRISP nel microonde.
Do not use the CRISP function in the microwave.

Rispettando questi consigli, i tuoi stampi Pavoni Italia resisteranno a migliaia di utilizzi!

By following these guidelines, you will be able to use your Pavoni Italia moulds thousands of times!



GĒDRIG GROĻĒT





Cédric Grolet

Il sogno della perfezione. Ogni forma è studiata con delle piccole varianti, piccoli dettagli che sapranno donare al prodotto finito un vero valore aggiunto. Tre tipologie di stampi in silicone, dalla tortiera allo stampo per monoporzioni, fino ad arrivare allo stampo per arricchire mini tart, tutti ispirati dalla mente creativa di Cédric Grolet per Pavoni Italia: ecco Citron, Marron e Noisette.

The dream of perfection. Each shape is designed with small variations, tiny details that will give the finished product real added value. Three types of silicone moulds, from the cake mould to the single-serving moulds, to the mould for enhancing mini tarts; all inspired by the creative mind of Cédric Grolet for Pavoni Italia: here are Citron (lemon), Marron (chestnut) and Noisette (hazelnut).



Guarda i video dedicati a **Cédric Grolet** sul canale Youtube di Pavoni Italia
Watch the videos **Cédric Grolet** on Pavoni Italia's Youtube channel



Pavoduo 300x175 mm

Monoporzioni
Single-serving portions

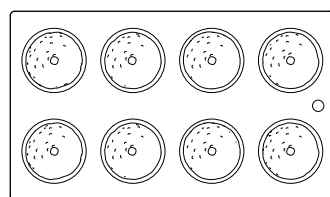
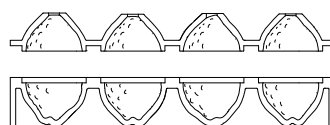

AF006
Citron

Ø mm 53x70 h
~ 85 ml

8 impronte - indents

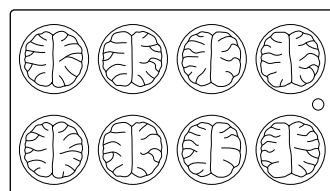
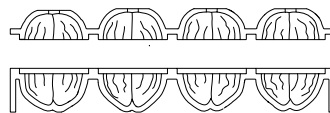

AF007
Marron

Ø mm 53x55 h
~ 85 ml

8 impronte - indents

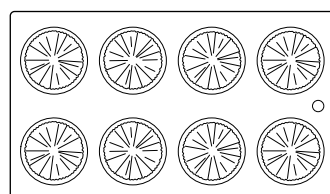
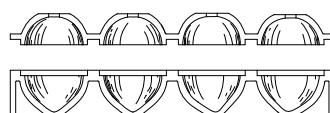

AF008
Noisette

Ø mm 54x60 h
~ 82 ml

8 impronte - indents



Pavoflex 400x300 mm

Crostate monoporzione Single-serving tarts

PX4359
Citron

Ø mm 60x37 h
~ 65 ml

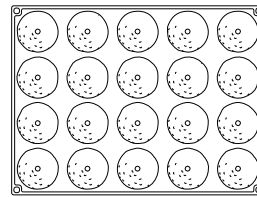

20 impronte - indents
abbinabile alla fascia
microforata - combined
with the micro-perforated
band **XF7020**
vedi pag - see page 163



PX4357
Marron

Ø mm 60x35 h
~ 65 ml

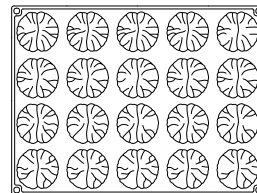

20 impronte - indents
abbinabile alla fascia
microforata - combined
with the micro-perforated
band **XF7020**
vedi pag - see page 163



PX4358
Noisette

Ø mm 60x35 h
~ 65 ml

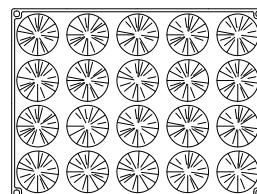

20 impronte - indents
abbinabile alla fascia
microforata - combined
with the micro-perforated
band **XF7020**
vedi pag - see page 163

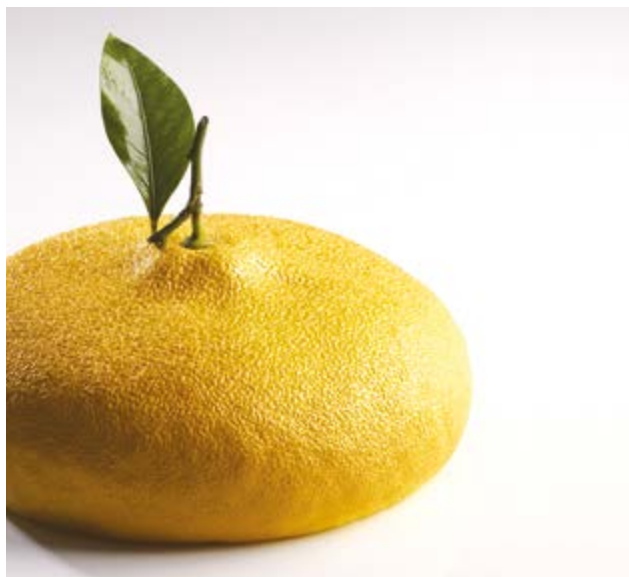

Pavocake

Torte Cakes

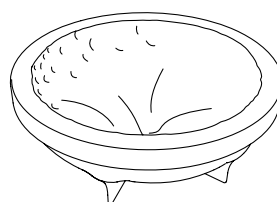

KE057
Citron

Ø mm 180x70 h
~ 1215 ml

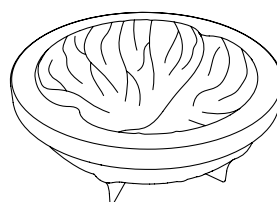

KE056
Marron

Ø mm 180x71 h
~ 1140 ml

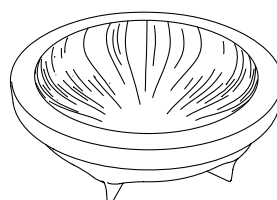

KE055
Noisette

Ø mm 180x70 h
~ 1155 ml

Progetto Crostate







FUSTO III
MILANO

Gianluca Fusto x Progetto Crostate

Progetto Crostate nasce da un buono - che fa cosa buone - e Pavoni Italia. Un kit creativo di fasce inox lisce, fasce inox microforate, stampi in silicone e tappetino microforato Forosil per interpretare in modo nuovo un classico della pasticceria. Crostate classiche e moderne, monoporzioni, straordinari effetti 3D, pensati per far combaciare l'arte con la pasticceria e dare nuove emozioni.

Progetto Crostate is the result of the collaboration between Gianluca Fusto and Pavoni Italia. A creative kit made up of smooth and micro-perforated stainless steel bands, silicone moulds and Forosil micro-perforated mat, allowing you to reinterpret in a new way a classic of pastry. Classic and modern tarts, single-serving tarts, extraordinary 3D effects, designed to match art with pastry and inspire new emotions.



Guarda i video dedicati a **Progetto Crostate** sul canale Youtube di Pavoni Italia

Watch the videos **Progetto Crostate** on Pavoni Italia's Youtube channel

Crostate Tarts

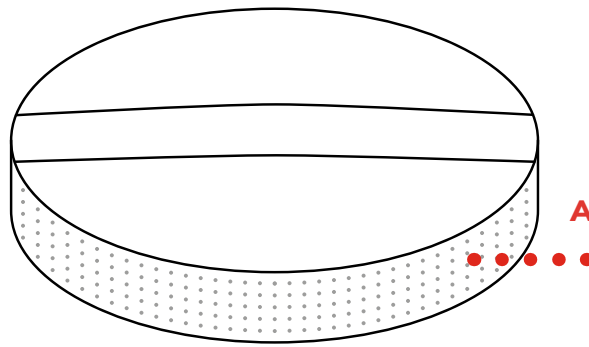

Classic

fasce inox microforate per realizzare una frolla perfetta
micro-perforated stainless steel bands for a perfect shortcrust pastry

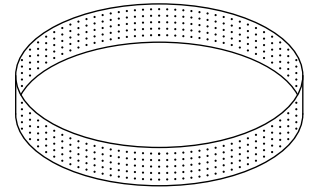

fasce inox lisce per creare strati e inserimenti a misura compatibili con le fasce forate
smooth stainless steel bands to create layers compatible with the micro-perforated bands

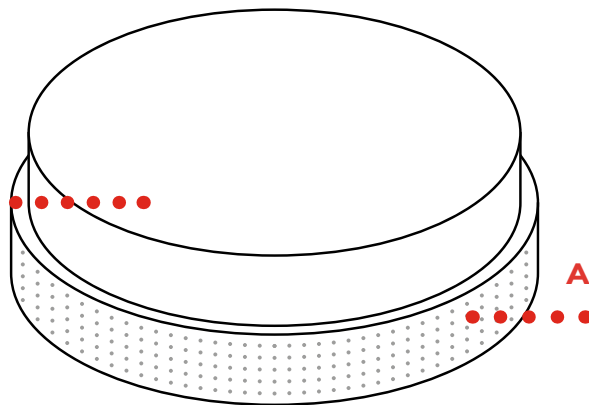
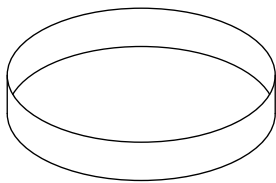

Modern

fasce inox microforate per realizzare una frolla perfetta
micro-perforated stainless steel bands for a perfect shortcrust pastry

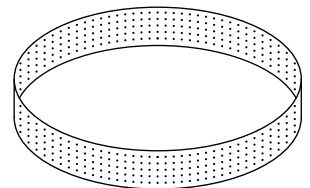

stampi in silicone per top dalle forme tridimensionali moderne, a tutto tondo
silicone moulds to create tops with modern and 3D shapes

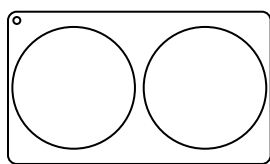

NEW

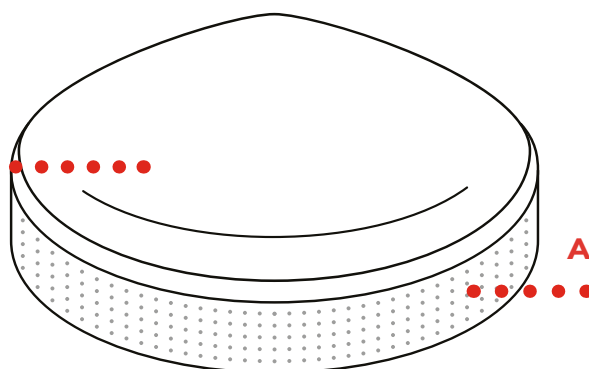

3D Modern

fasce inox microforate per realizzare una frolla perfetta
micro-perforated stainless steel bands for a perfect shortcrust pastry

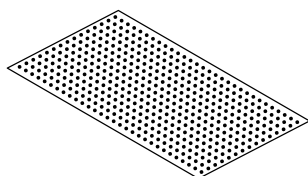
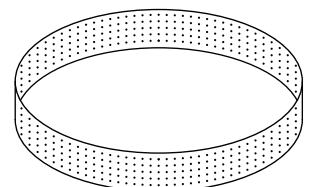

G
tappetino Forosil in silicone microforato
Forosil silicone micro-perforated pad

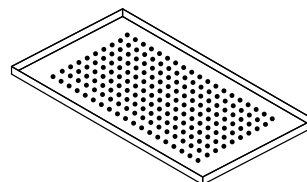

H
teglia microforata o griglia
micro-perforated tray or grid

Crostate monoporzione Single-serving tarts

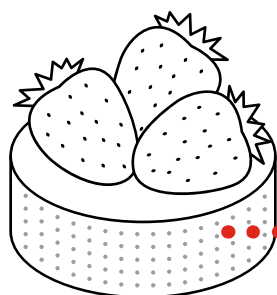

Classic

fasce inox microforate per
monoporzioni
micro-perforated stainless
steel bands for single-
serving tarts

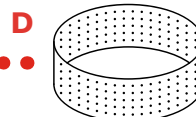

fasce inox lisce per
monoporzioni
smooth stainless steel bands
for single-serving tarts

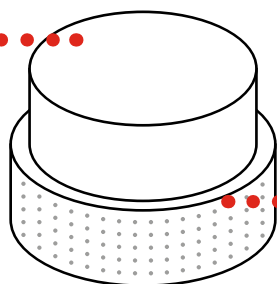
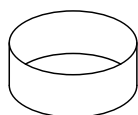

Modern

fasce inox microforate per
monoporzioni
micro-perforated stainless
steel bands for single-
serving tarts

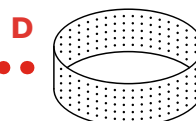

stampi in silicone per crostate
monoporzione
silicone mould for single-serving tarts

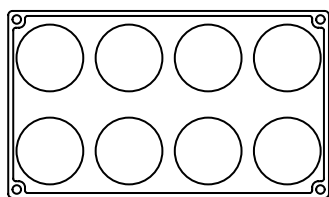

NEW

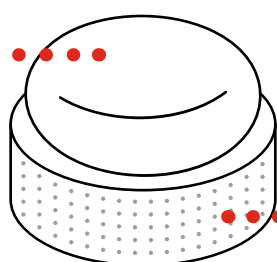

3D Modern

fasce inox microforate per
crostate monoporzio
micro-perforated stainless
steel bands for single-
serving tarts

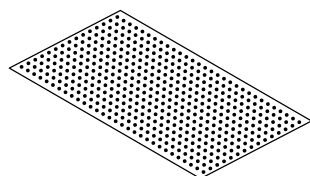
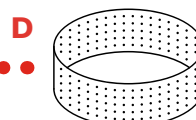

G
tappetino Forosil in
silicone microforato
Forosil silicone micro-
perforated pad

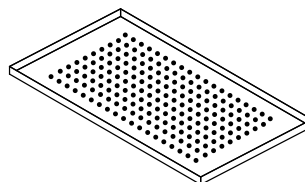

H
teglia microforata o
griglia
micro-perforated tray or
grid

Crostate Tarts







Top 3D

I Top 3D sono la novità e il perfetto completamento di Progetto Crostate: l'interpretazione contemporanea della crostata, da apprezzare finalmente a 360°. Un'idea unica, capace di stupire la clientela più raffinata, sviluppata insieme a Gianluca Fusto.

The new Top moulds are the perfect range extension of Progetto Crostate and the contemporary interpretation of the tart with a 3D look. A unique idea able to be appreciated by the most refined customers and developed together with Gianluca Fusto.

NEW

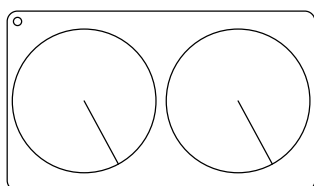

TOP17

Frisbee

dim stampo - mould mm 300x175

Ø mm 140x33 h

~ 285 ml

abbinabile alla fasce tonde microforate
can be combined with the micro-perforated round bands

NEW

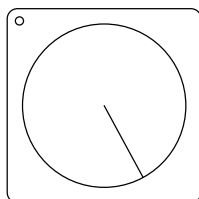

TOP18

Frisbee

dim stampo - mould mm 190x190

Ø mm 160x37 h

~ 414 ml

abbinabile alla fasce tonde microforate
can be combined with the micro-perforated round bands

NEW

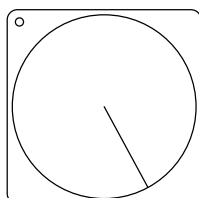

TOP19

Frisbee

dim stampo - mould
mm 190x190

Ø mm 180x40 h

~ 572 ml

abbinabile alla fasce tonde microforate
can be combined with the micro-perforated round bands



Fasce inox microforate per crostate rotonde

Micro-perforated stainless steel round bands for tarts



CODE	DIMENSION (mm)	PORTIONS
XF1520	Ø150x20 h	2/4
XF1720	Ø170x20 h	4/6
XF1920	Ø190x20 h	6/8
XF2120	Ø210x20 h	10/12
XF2320	Ø230x20 h	14/16
XF2520	Ø250x20 h	18/20
XF1535	Ø150x35 h	2/4
XF1735	Ø170x35 h	4/6
XF1935	Ø190x35 h	6/8
XF2135	Ø210x35 h	10/12
XF2335	Ø230x35 h	14/16

Fasce inox lisce per crostate rotonde

Smooth stainless steel round bands for tarts



CODE	DIMENSION (mm)	PORTIONS
X1202	Ø120x20 h	2/4
X1402	Ø140x20 h	2/4
X1602	Ø160x20 h	4/6
X1802	Ø180x20 h	6/8
X2002	Ø200x20 h	10/12
X2202	Ø220x20 h	14/16
X2402	Ø240x20 h	18/20



Fasce inox microforate per crostate a forma di cuore

Heart shaped micro-perforated stainless steel bands for tarts



CODE	DIMENSION (mm)	PORTIONS
XF25	160x150x20 h	2/4
XF27	180x170x20 h	4/6
XF29	205x190x20 h	6/8
XF31	225x210x20 h	14/16
XF26	160x150x35 h	2/4
XF28	180x170x35 h	4/6
XF30	205x190x35 h	10/12
XF32	225x210x35 h	14/16

Fasce inox lisce per crostate a forma di cuore

Heart shaped smooth stainless steel bands for tarts



CODE	DIMENSION (mm)	PORTIONS
X32	130x120x20 h	2/4
X31	150x140x20 h	4/6
X33	170x160x20 h	6/8
X34	195x180x20 h	10/12
X35	220x200x20 h	14/16



Fasce inox microforate per crostate triangolari

Micro-perforated stainless steel triangular bands for tarts



CODE	DIMENSION (mm)	PORTIONS
XF17	175x160x20 h	2/4
XF21	220x200x20 h	8/10
XF18	175x160x35 h	2/4
XF22	220x200x35 h	8/10

Fasce inox lisce per crostate triangolari

Smooth stainless steel triangular bands for tarts



CODE	DIMENSION (mm)	PORTIONS
X24	150x130x20 h	2/4
X23	170x150x20 h	2/4
X28	195x170x20 h	8/10
X27	215x190x20 h	8/10



Fasce inox microforate per crostate a forma di ellisse Micro-perforated stainless steel elliptic bands for tarts



CODE	DIMENSION (mm)	PORTIONS
XF19	210x115x20 h	2/4
XF23	270x150x20 h	6/8
XF20	210x115x35 h	2/4
XF24	270x150x35 h	6/8

Fasce inox lisce per crostate a forma di ellisse Smooth stainless steel elliptic bands for tarts



CODE	DIMENSION (mm)	PORTIONS
X26	180x90x20 h	2/4
X25	205x110x20 h	2/4
X30	235x120x20 h	6/8
X29	260x140x20 h	6/8



Fasce inox microforate per crostate ovali

Micro-perforated stainless steel oval bands for tarts



CODE	DIMENSION (mm)	PORTIONS
XFO197020	190x70x20 h	2/4
XFO299020	290x90x20 h	6/8
XFO197035	190x70x35 h	2/4
XFO299035	290x90x35 h	6/8

Fasce inox lisce per crostate ovali

Smooth stainless steel oval bands for tarts



CODE	DIMENSION (mm)	PORTIONS
XO186020	180x60x20 h	2/4
XO288020	280x80x20 h	6/8

Fasce inox microforate per crostate quadrate

Micro-perforated stainless steel square bands for tarts

angoli arrotondati - rounded corners



CODE	DIMENSION (mm)	PORTIONS
XF03	150x150x20 h	2/4
XF04	190x190x20 h	6/8
XF05	150x150x35 h	2/4
XF06	190x190x35 h	6/8

angoli vivi - sharp corners



CODE	DIMENSION (mm)	PORTIONS
XF151520	150x150x20 h	2/4
XF191920	190x190x20 h	6/8
XF151535	150x150x35 h	2/4
XF191935	190x190x35 h	6/8

Fasce inox lisce per crostate quadrate

Smooth stainless steel square bands for tarts

angoli arrotondati - rounded corners



CODE	DIMENSION (mm)	PORTIONS
X03	120x120x20 h	2/4
X04	140x140x20 h	2/4
X05	160x160x20 h	4/6
X06	180x180x20 h	6/8

angoli vivi - sharp corners

CODE	DIMENSION (mm)	PORTIONS
X121220	120x120x20 h	2/4
X141420	140x140x20 h	2/4
X161620	160x160x20 h	4/6
X181820	180x180x20 h	6/8

Fasce inox microforate per crostate rettangolari

Micro-perforated stainless steel rectangular bands for tarts

angoli arrotondati - rounded corners

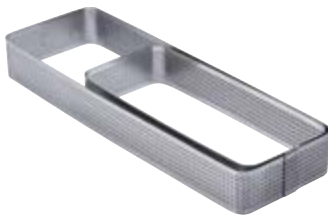

CODE	DIMENSION (mm)	PORTIONS
XF07	190x80x20 h	2/4
XF08	290x90x20 h	6/8
XF09	190x80x35 h	2/4
XF10	290x90x35 h	6/8

angoli vivi - sharp corners



CODE	DIMENSION (mm)	PORTIONS
XF197020	190x80x20 h	2/4
XF299020	290x90x20 h	6/8
XF197035	190x80x35 h	2/4
XF299035	290x90x35 h	6/8

Fasce inox lisce per crostate rettangolari

Smooth stainless steel rectangular bands for tarts

angoli arrotondati - rounded corners



CODE	DIMENSION (mm)	PORTIONS
X07	180x60x20 h	2/4
X08	280x80x20 h	6/8

angoli vivi - sharp corners

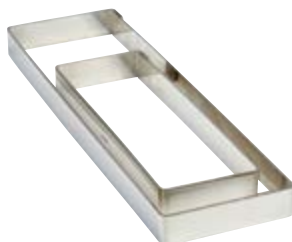

CODE	DIMENSION (mm)	PORTIONS
X186020	180x60x20 h	2/4
X288020	280x80x20 h	6/8



pavoni. xi

Fasce inox lisce per crostate

Smooth stainless steel bands for tarts

Tonda - Round*



CODE	DIMENSION (mm)	SPESSORE THICKNESS
X1202	Ø 120x20 h	15/10
X1402	Ø 140x20 h	15/10
X1602	Ø 160x20 h	15/10
X1802	Ø 180x20 h	15/10
X2002	Ø 200x20 h	15/10
X2202	Ø 220x20 h	15/10
X2402	Ø 240x20 h	15/10
X2602	Ø 260x20 h	15/10
X2802	Ø 280x20 h	15/10
X1403	Ø 140x30 h	15/10
X1603	Ø 160x30 h	15/10
X1803	Ø 180x30 h	15/10
X3910	Ø 100x40 h	15/10
X3912	Ø 120x40 h	15/10
X3914	Ø 140x40 h	15/10
X3916	Ø 160x40 h	15/10
X3918	Ø 180x40 h	15/10
X3920	Ø 200x40 h	15/10
X3922	Ø 220x40 h	15/10
X3924	Ø 240x40 h	15/10
X3926	Ø 260x40 h	15/10
X3928	Ø 280x40 h	15/10
X3930	Ø 300x40 h	15/10
X3932	Ø 320x40 h	15/10
X3934	Ø 340x40 h	15/10
X3936	Ø 360x40 h	15/10
X4010	Ø 100x50 h	15/10
X4012	Ø 120x50 h	15/10

CODE	DIMENSION (mm)	SPESSORE THICKNESS
X4014	Ø 140x50 h	15/10
X4016	Ø 160x50 h	15/10
X4018	Ø 180x50 h	15/10
X4020	Ø 200x50 h	15/10
X4022	Ø 220x50 h	15/10
X4024	Ø 240x50 h	15/10
X4026	Ø 260x50 h	15/10
X4028	Ø 280x50 h	15/10
X4030	Ø 300x50 h	15/10
X4032	Ø 320x50 h	15/10
X4034	Ø 340x50 h	15/10
X4036	Ø 360x50 h	15/10

Rettangolare - Rectangular*



CODE	DIMENSION (mm)	SPESSORE THICKNESS
X411836	350x170x40 h	20/10
X413040	390x290x40 h	20/10
X414060	590x390x40 h	20/10
X421836	350x170x50 h	20/10
X423040	390x290x50 h	20/10
X424060	590x390x50 h	20/10

Cuore - Heart



CODE	DIMENSION (mm)	SPESSORE THICKNESS
X7718	Ø 180x40 h	10/10
X7720	Ø 200x40 h	10/10
X7722	Ø 220x40 h	10/10
X7724	Ø 240x40 h	10/10
X7726	Ø 260x40 h	10/10

* A richiesta si possono realizzare misure particolari (quantità min. 20 pz).

* Special measures can be requested (min quantity 20 pcs).

Crostate monoporzione

Single-serving tarts







Fasce inox microforate per crostate monoporzione

Micro-perforated stainless steel bands for single-serving tarts

Il vero segreto di Progetto Crostate, ideale per realizzare una frolla perfetta. La presenza dei microfori assicura una cottura omogenea, evitando il collasso dei bordi e una doratura ottimale dei fondi.

The real secret of Progetto Crostate, for making the perfect shortcrust pastry. The micro-perforations of the bands ensure even baking, preventing the edges from collapsing, and optimal browning of the base.



XF11

mm 100x55x20 h

abbinabile a
combined with
PX3201 or **X17**



XF15

mm 125x30x20 h

abbinabile a
combined with
PX3204 or **X21**



XF12

mm 96x57x20 h

abbinabile a
combined with
PX3202 or **X18**



XF16

mm 85x75x20 h

abbinabile a
combined with
PX3205 or **X22**



XF13

mm 90x50x20 h

abbinabile a
combined with
PX3203 or **X19**



XF7020

Ø mm 70x20 h

abbinabile a
combined with
PX3200 or **X0602**



XF14

mm 75x70x20 h

abbinabile a
combined with
PX3206 or **X20**



XF0656520

mm 65x65x20 h

abbinabile a
combined with
PX3207 or **X37**



Fasce inox lisce per crostate monoporzione

Smooth stainless steel bands for single-serving tarts

Le fasce lisce in acciaio inox sono pensate per creare strati e inserimenti a misura perfettamente compatibili con le fasce forate.

The smooth stainless steel bands are designed to create layers and inserts that fit perfectly within the perforated bands.

**X17**

mm 90x45x20 h

abbinabile a
combined with
XF11

**X21**

mm 115x20x20 h

abbinabile a
combined with
XF15

**X18**

mm 85x45x20 h

abbinabile a
combined with
XF12

**X22**

mm 75x65x20 h

abbinabile a
combined with
XF16

**X19**

mm 80x40x20 h

abbinabile a
combined with
XF13

**X0602**

Ø mm 60x20 h

abbinabile a
combined with
XF7020

**X20**

mm 65x60x20 h

abbinabile a
combined with
XF14

**X37**

mm 55x55x20 h

abbinabile a
combined with
XFO656520



Pavoflex 300x175 mm

Una nuova linea di stampi in silicone per arricchire crostate monoporzione. Dodici differenti forme per creare raffinate sagome tridimensionali, ispirate al mondo del design.

A new line of silicone moulds to enhance single-serving tarts. Twelve different designs to create refined three-dimensional shapes, inspired by the world of design.

NEW

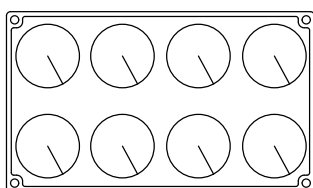

PX3208
Frisbee

Ø mm 60x28 h
~ 48 ml
8 impronte - indents
abbinabile a - combined
with **XF7020**

NEW

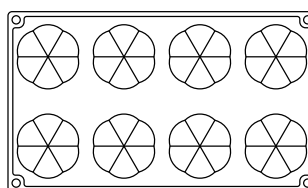

PX3209
Charm

Ø mm 60x21,5 h
~ 46 ml
8 impronte - indents
abbinabile a - combined
with **XF7020**

NEW

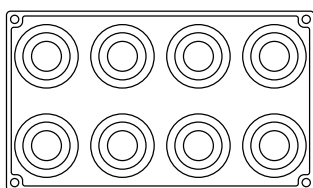

PX3210
Step

Ø mm 60x32 h
~ 49,5 ml
8 impronte - indents
abbinabile a - combined
with **XF7020**

NEW

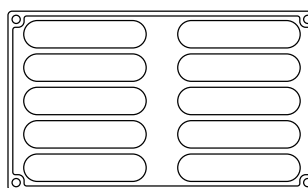

PX3211
Pill

mm 117x24,5x19,5 h
~ 40 ml
10 impronte - indents
abbinabile a - combined
with **XF15**



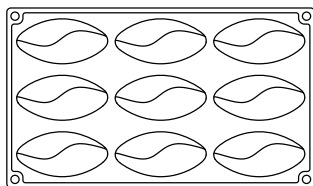

PX3201
Shell

mm 86x41x22 h
~ 43 ml
9 impronte - indents
abbinabile a - combined
with **XF11**

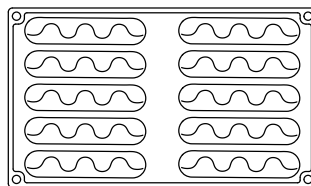

PX3204
Sand

mm 115x24x20 h
~ 38 ml
10 impronte - indents
abbinabile a - combined
with **XF15**

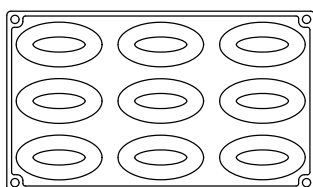

PX3202
Cameo

mm 81x41x19 h
~ 42 ml
9 impronte - indents
abbinabile a - combined
with **XF12**

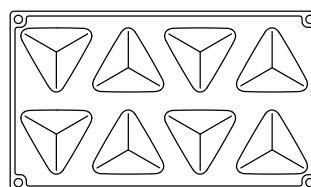

PX3205
Pyramid

mm 66x60x28 h
~ 46 ml
8 impronte - indents
abbinabile a - combined
with **XF16**

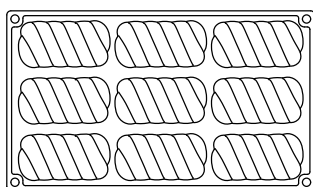

PX3203
Spring

mm 84x41x20 h
~ 50 ml
9 impronte - indents
abbinabile a - combined
with **XF13**

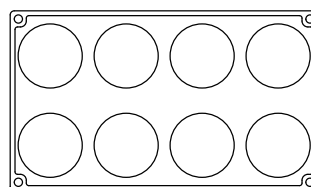

PX3200
Round

Ø mm 60x20 h
~ 48 ml
8 impronte - indents
abbinabile a - combined
with **XF7020**

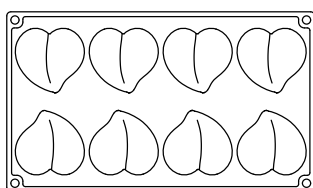

PX3206
Heart

mm 65x60x21 h
~ 46 ml
8 impronte - indents
abbinabile a - combined
with **XF14**

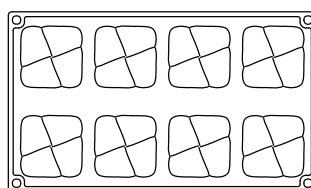

PX3207
Rock

mm 55x55x23 h
~ 54 ml
8 impronte - indents
abbinabile a - combined
with **XF0656520**

Fasce inox microforate per crostate monoporzione

Micro-perforated stainless steel bands for single-serving tarts

Tonda - Round



CODE	DIMENSION (mm)
XF9020	Ø 90x20 h
XF1120	Ø 110x20 h

Quadrata con angoli arrotondati - Square with rounded corners



CODE	DIMENSION (mm)
XF01	85x85x20 h
XF02	105x105x20 h

Fasce inox lisce per crostate monoporzione

Smooth stainless steel bands for single-serving tarts

Tonda - Round



CODE	DIMENSION (mm)
X0802	Ø 80x20 h
X1002	Ø 100x20 h

Quadrata con angoli arrotondati - Square with rounded corners



CODE	DIMENSION (mm)
X01	70x70x20 h
X02	90x90x20 h

Accessori - Accessories

Tappetino in silicone microforato Silicone micro-perforated mat

Grazie alla sua antiaderenza è il complemento perfetto da abbinare alla teglia. La presenza dei microfori facilita la distribuzione ottimale del calore.

Thanks to its non-stick properties, it is the perfect complement for the tray. The micro holes help the optimal distribution of heat.



CODE	DIMENSION (mm)
FOROSIL64	585x385

Teglia in alluminio microforata e griglia Micro-perforated aluminium tray and grid

Con i suoi microfori la teglia permette una migliore distribuzione del calore e una cottura e resa ottimale del prodotto finito.

Thanks to its micro holes, the tray allows a better distribution of heat, for an optimal baking and a perfect finished product.

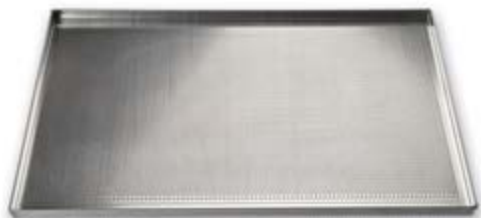

CODE	DIMENSION (mm)
JF06040D20P00G	600x400x20

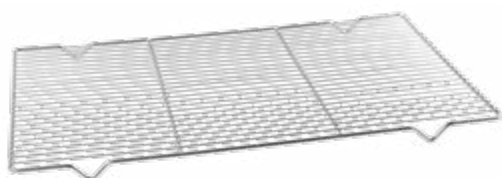

CODE	DIMENSION (mm)
GLA64	600x400

My Valentine







Pavocake



KE049S

Beloved
by Emmanuele Forcone

mm 250x140x60 h
~ 1200 ml

coppapasta incluso
cutter included

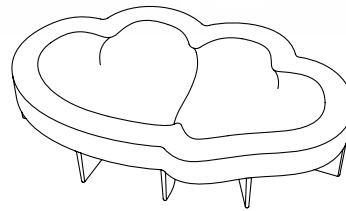

KE060

Lovely
by Antonio Bachour

mm 200x126x50 h
~ 1000 ml

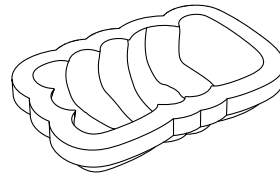

KE061

Lovely
by Antonio Bachour

mm 166x103x40 h
~550 ml

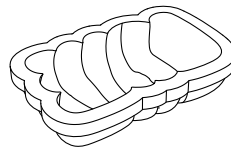

KE016

Passion

mm 175x165x58 h
~ 960 ml

abbinabile con
inserimento:
can be combined with
insert:

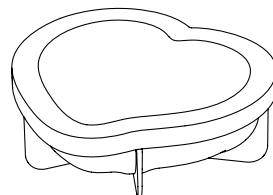

KE017

vedi pag - see page 257



Pavoflex 400x300 mm



PX4370S

Beloved

by Emmanuele Forcone

mm 127x71x38 h
~ 200 ml

9 impronte - indents

coppapasta incluso
cutter included

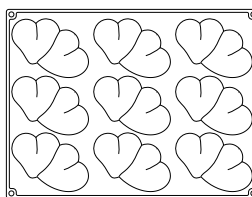

PX4363

Lovely

by Antonio Bachour

mm 80x43x36 h
~ 90 ml

15 impronte - indents

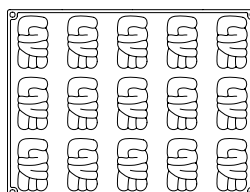

PX4305

Passion

mm 71x66x38 h
~ 100 ml

12 impronte - indents

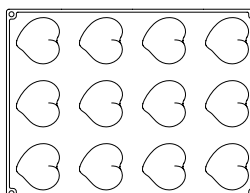

PX4325

Passion

mm 40x30x20 h
~ 18 ml

30 impronte - indents

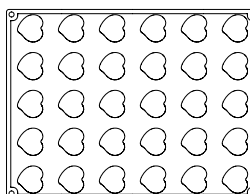

Progetto Crostate

I cuori di Progetto Crostate sono perfetti per un San Valentino indimenticabile.

Progetto Crostate's hearts are perfect for an unforgettable Valentine's Day.

Scopri di più a pag 150 e 160
Discover more at page 150 and 160



Stampi termoformati serigrafati Silkscreened thermoformed moulds



T927

Ø mm 25 h

4 modelli
10 fogli
1200 impronte

4 designs
10 sheets
1200 indents



T821

mm 33x29 h

4 modelli
10 fogli
630 impronte

4 designs
10 sheets
630 indents



T225/G

mm 48x41 h

6 modelli
10 fogli
360 impronte

6 designs
10 sheets
360 indents



Stampi per praline Praline moulds

Dimensione stampo - Mould size: mm 275x135

21 pezzi per stampo - 21 pcs for mould

Disponibile - Available BPA free



PC17

mm 30x30x17 h
+/- 10 g



PC55

by Fabrizio Fiorani

mm 29x30x16 h
+/- 10 g





PC58

by Antonio Bachour

mm 33x29x17 h
+/- 10 g

Serigrafie 340x265 mm Silkscreens 340x265 mm

-  Cioccolato fondente - Dark chocolate
-  Cioccolato al latte - Milk chocolate
-  Cioccolato bianco - White chocolate



SD42R

rosso - red



30 fogli per confezione
30 sheets per box



SD61

rosso nero - red black



30 fogli per confezione
30 sheets per box



SD83

lilla viola bianco - lilac purple white



30 fogli per confezione
30 sheets per box



Serigrafie 400x250 mm Silkscreens 400x250 mm



SD139

rosso bianco - red white



20 fogli per confezione
20 sheets per box



Catering



Pavoflex 300x175 mm

Belli, facili e veloci. Gli stampi Pavoflex 300x175 mm sono ideali per straordinarie preparazioni di buffet, perché garantiscono risultati eccezionali mentre rendono più rapido il lavoro. Forme con volumi ideali per trasformare ogni banchetto in un successo.

Beautiful, easy and quick to realize. Pavoflex 300x175 mm moulds are perfect for astonishing preparations in your buffet, as they allow optimal results and they make your work faster. Shapes with the right volumes to make every buffet a success.

NEW

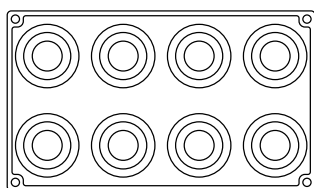

PX3210
Step

Ø mm 60x32 h
~ 49,5 ml
8 impronte - indents

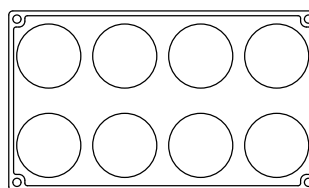

PX3200
Round

Ø mm 60x20 h
~ 48 ml
8 impronte - indents

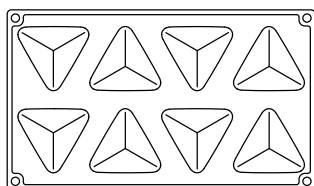

PX3205
Pyramid

mm 66x60x28 h
~ 46 ml
8 impronte - indents

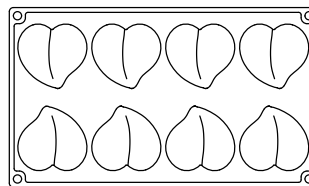

PX3206
Heart

mm 65x60x21 h
~ 46 ml
8 impronte - indents

Monoporzioni
Single-serving
portions







Pavoflex 400x300 mm



PX4353S

Pastel

by Antonio Bachour

mm 125x28x28 h
~ 90 ml

14 impronte - indents

coppapasta incluso
cutter included

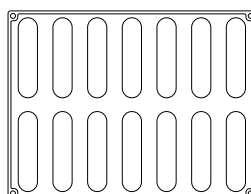

Antonio Bachour x Pavoflex 400x300 mm

Una linea di monoporzioni sviluppata con Pavoni Italia, firmata da uno dei più grandi e noti maestri di pasticceria internazionali. Sono cinque le novità tra le forme morbide e sinuose firmate da Antonio Bachour, ispirate a forme floreali esotiche e alla natura. Un eccezionale punto di partenza, per interpretazioni che sapranno stupire.

A line of single-serving portions developed with Pavoni Italia, designed by one of the greatest and most famous international Pastry Chefs. There are five new designs among the soft and curvy shapes created by Antonio Bachour, inspired by exotic floral shapes and nature. An exceptional starting point for creations that cannot fail to impress.



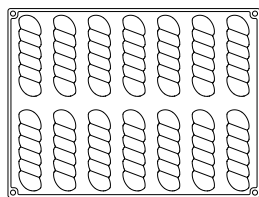

PX4373

Domino

by Antonio Bachour

NEW

mm 126x33x32 h
~ 80 ml

14 impronte - indents



Pavoflex 400x300 mm

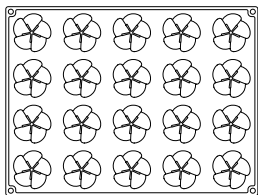

PX4371

Lotus

by Antonio Bachour

NEW

Ø mm 57x63 h

~ 105 ml

20 impronte - indents



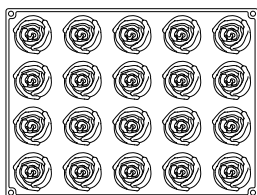

PX4376

Romance

by Antonio Bachour

NEW

mm 56x54x61 h
~ 106 ml

20 impronte - indents



Pavoflex 400x300 mm

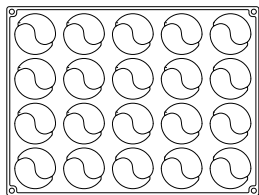

PX4375

Yoga

by Antonio Bachour

NEW

Ø mm 60x42 h
~ 102 ml

20 impronte - indents



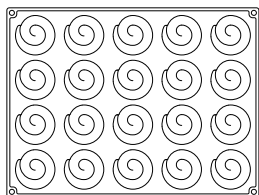

PX4374

Nautilus

by Antonio Bachour

NEW

Ø mm 60x40 h

~ 106 ml

20 impronte - indents





Pavoflex 400x300 mm

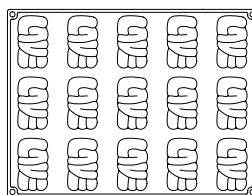

PX4363

Lovely

by Antonio Bachour

mm 80x43x36 h

~ 90 ml

15 impronte - indents

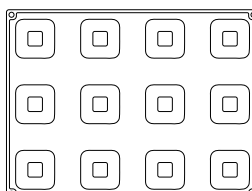

PX4361

Tulum

by Antonio Bachour

mm 56x56x34 h

~ 90 ml

12 impronte - indents

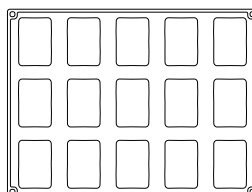

PX4364

Gummy

by Antonio Bachour

mm 74x50x27 h

~ 90 ml

15 impronte - indents

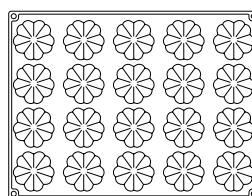

PX4362

Gel

by Antonio Bachour

Ø mm 60x63 h
~ 90 ml

20 impronte - indents



PX4360S

Miami

by Antonio Bachour

mm 118x33x42 h
~ 90 ml

14 impronte - indents

coppapasta incluso
cutter included

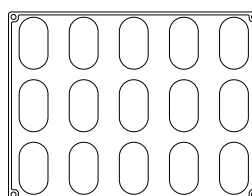
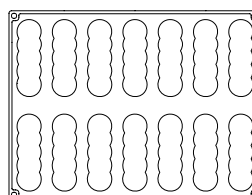

PX4356

Delish

by Antonio Bachour

mm 82x44x37 h
~ 100 ml

15 impronte - indents



Pavoflex 400x300 mm



PX4351S

Confy

by Antonio Bachour

mm 128x30x28 h
~ 90 ml

14 impronte - indents

coppapasta incluso
cutter included

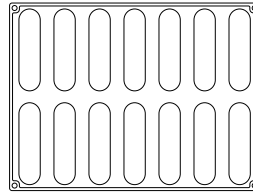

PX4365

Tulip

by Antonio Bachour

Ø mm 55x56 h
~ 90 ml

20 impronte - indents

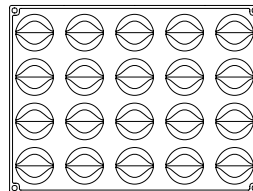

PX4352S

Pelota

by Antonio Bachour

mm 130x32x28 h
~ 90 ml

14 impronte - indents

coppapasta incluso
cutter included

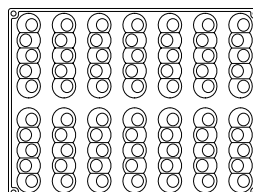

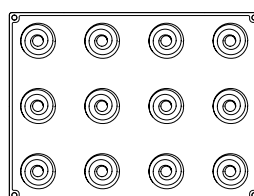

PX4340

Over

by Antonio Bachour

Ø mm 65x50 h
~ 90 ml

12 impronte - indents

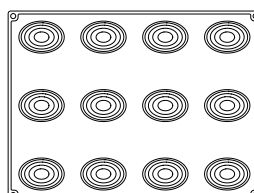

PX4341

Polly

by Antonio Bachour

mm 78x56x43 h
~ 90 ml

12 impronte - indents

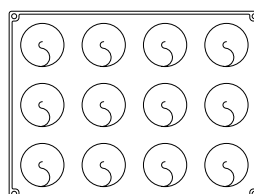

PX4355

Jasmine

by Antonio Bachour

Ø mm 65x57 h
~ 100 ml

12 impronte - indents

Pavoflex 400x300 mm

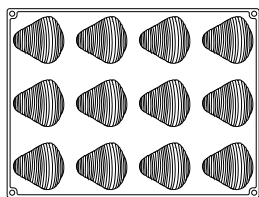

PX4377S

Sfogliatella

by Giuseppe Amato

mm 77x71,5x35 h
~ 90 ml

12 impronte - indents



coppapasta incluso
cutter included

NEW



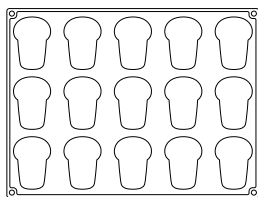

PX4382S
Babà

mm 78x54x46 h
~ 96 ml

15 impronte - indents

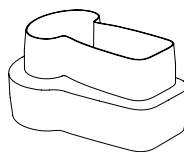

coppapasta incluso
cutter included

NEW





Pavoflex 400x300 mm



PX4370S

Beloved

by Emmanuele Forcone

mm 127x71x38 h
~ 200 ml

9 impronte - indents

coppapasta incluso
cutter included

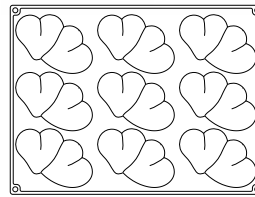

PX4305

Passion

mm 71x66x38 h
~ 100 ml

12 impronte - indents

photo credits:
Andrea Tortora
Benedetta Bassanelli

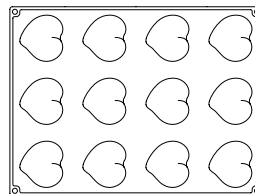

PX4343

Mister

mm 58x58x33 h
~ 90 ml

12 impronte - indents

PX4345

Miss

mm 78x48x33 h
~ 90 ml

15 impronte - indents

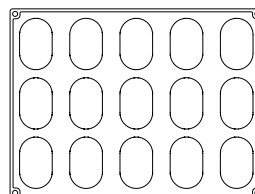
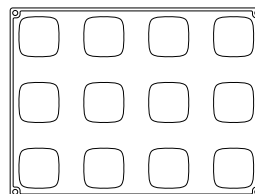

Scopri di più sulle serigrafie **SD134** e **SD133** a pag 117 - Discover more about silkscreens **SD134** and **SD133** at page 117



NEW

PX4372
Gnammy

Ø mm 68x34 h
~ 90 ml

12 impronte - indents

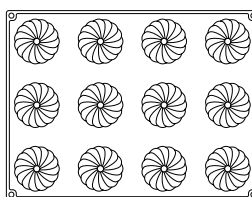

PX4349
Loop

Ø mm 65x34 h
~ 90 ml

12 impronte - indents

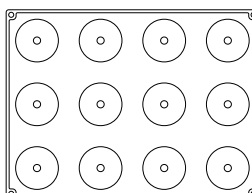

photo credits:
Richard Hawke



PX4307
Moon

Ø mm 61x50 h
~ 100 ml

12 impronte - indents

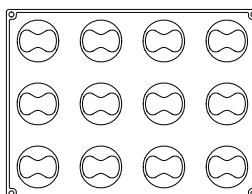
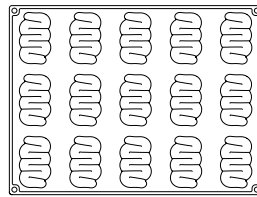

photo credits:
Cécile Moritel



Pavoflex 400x300 mm



PX4342

Turn

mm 80x46x38 h
~ 100 ml

15 impronte - indents

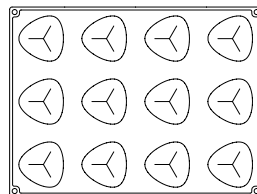

PX4303

Natural

mm 69x68x52 h
~ 100 ml

12 impronte - indents

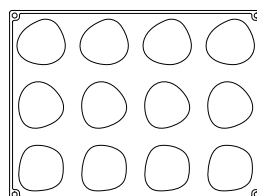

PX4301

Zen

Ø mm 68x32 h
~ 100 ml

12 impronte - indents

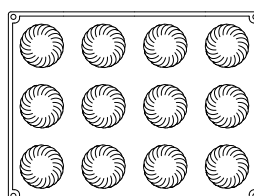

PX4317
Caleidon

Ø mm 66x34 h
~ 93 ml

12 impronte - indents

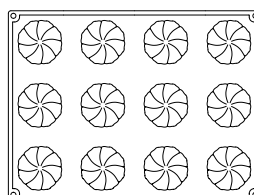

PX4322
Twister

Ø mm 66x35 h
~ 88 ml

12 impronte - indents

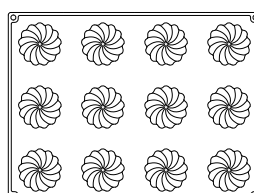

PX4308
Delice

Ø mm 64x52 h
~ 100 ml

12 impronte - indents

Pavoflex 400x300 mm

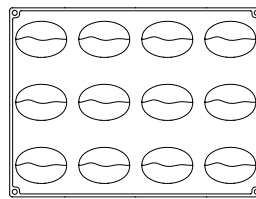

PX4312

Moka

mm 83x58x32 h

~ 100 ml

12 impronte - indents

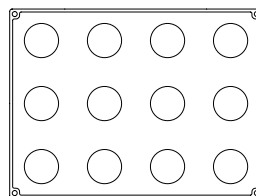

PX4302

Drop

Ø mm 66x47 h

~ 100 ml

12 impronte - indents

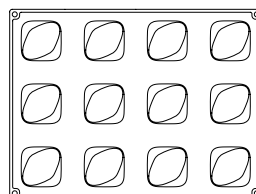

PX4306

Déco

mm 58x58x40 h

~ 100 ml

12 impronte - indents



PX4321
Planet

Ø mm 66x34 h
~ 93 ml

12 impronte - indents

photo credits:
Nicolas Bacheyre

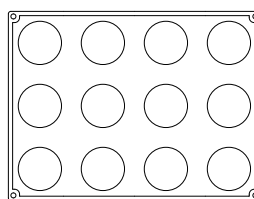

PX4327
Battuta d'inizio
by Davide Oldani

Ø mm 55
~ 80 ml

20 impronte - indents

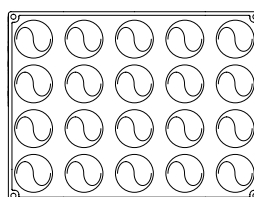

PX4338
Battuta d'inizio
by Davide Oldani

Ø mm 45
~ 48 ml

24 impronte - indents

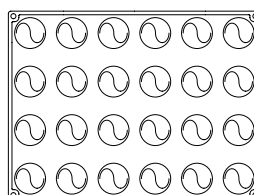

PX4304
Curvy

mm 83x53x42 h
~ 100 ml

12 impronte - indents

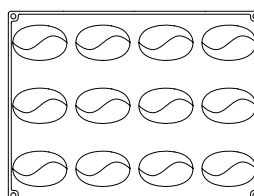



Pavoflex 400x300 mm

PX4329

Pear

by Emmanuele
Forcone

Ø mm 53x70 h
~ 90 ml

20 impronte - indents

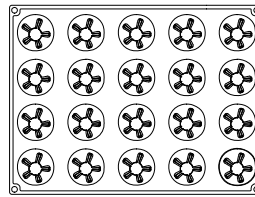

PX4330

Apple

by Emmanuele
Forcone

Ø mm 55x48 h
~ 90 ml

20 impronte - indents

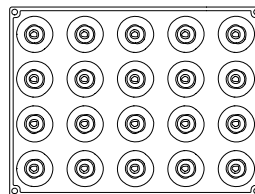

PX4331

Cherry

by Emmanuele
Forcone

mm 58x53x46 h
~ 90 ml

20 impronte - indents

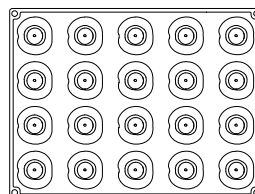

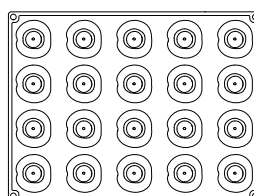

PX4331

Peach

by Emmanuele
Forcone

mm 58x53x46 h
~ 90 ml

20 impronte - indents

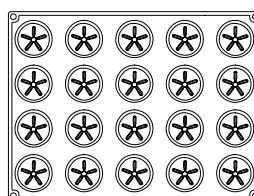

PX4332

Tangerine

by Emmanuele
Forcone

Ø mm 57x50 h
~ 90 ml

20 impronte - indents

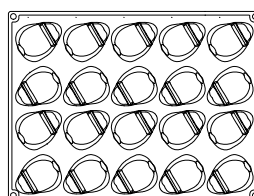

PX4333

Strawberry

by Emmanuele
Forcone

mm 71x54x46 h
~ 90 ml

20 impronte - indents



Pavoflex 400x300 mm

PX4335S

Square

by Gianluca Fusto

mm 68x68x15 h
~ 68 ml

12 impronte - indents

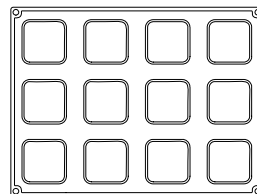

Il kit include - the kit includes:

coppapasta
inserimento
insert cutter mm
53x53

coppapasta biscotto
cookie cutter
mm 93x93



PX4337S

Rectangular

by Gianluca Fusto

mm 92x50x15 h
~ 67 ml

12 impronte - indents

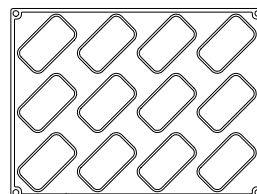

Il kit include - the kit includes:

coppapasta
inserimento
insert cutter
mm 77x35

coppapasta biscotto
cookie cutter
mm 117x75



Guarda il video dedicato a **Progetto Mono** sul canale Youtube di Pavoni Italia

Watch the video **Progetto Mono** on Pavoni Italia's Youtube channel



PX4334S

Round

by Gianluca Fusto

Ø mm 74x15 h
~ 64 ml

12 impronte - indents



Il kit include - the kit includes:

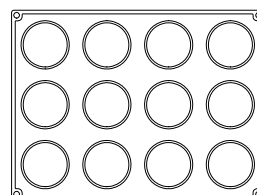

coppapasta inserimento
insert cutter
Ø mm 59

coppapasta biscotto
cookie cutter
Ø mm 99



PX4336S

Oval

by Gianluca Fusto

mm 93x62x15 h
~ 67 ml

12 impronte - indents

Il kit include - the kit includes:

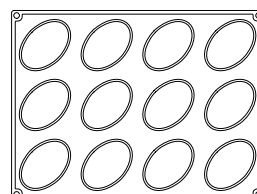

coppapasta inserimento
insert cutter
mm 79x35

coppapasta biscotto
cookie cutter
mm 118x87



Pavoflex 600x400 mm

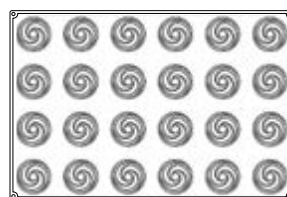

PX039
Bocciole

Ø mm 70x42 h
~ 130 ml

24 impronte - indents



Pavoflex 600x400 mm

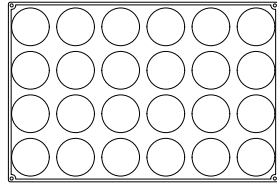

PX078
Daisy

Ø mm 74x15 h
~ 65 ml

24 impronte - indents

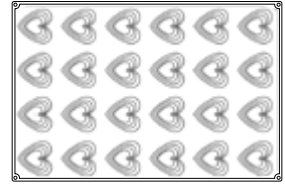

PX032
Love

mm 78x77x34 h
~ 110 ml

24 impronte - indents

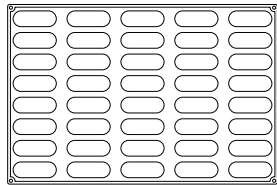

PX068
Gianduiotto

mm 90x30x53 h
~ 83 ml

40 impronte - indents

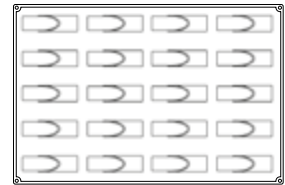

PX024
Flow

mm 120x33x32 h
~ 100 ml

20 impronte - indents

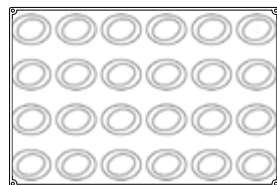

PX064
Wave

mm 83x62x35 h
~ 130 ml

24 impronte - indents



PX016
Intrigo

Ø mm 70x42 h
~ 100 ml

24 impronte - indents

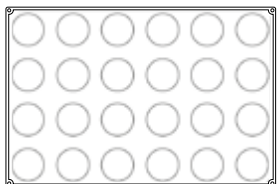

PX001
Semisfera

Ø mm 70x40 h
~ 120 ml

24 impronte - indents

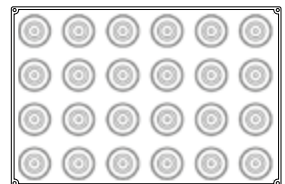

PX034
Ring

Ø mm 70x50 h
~ 110 ml

24 impronte - indents

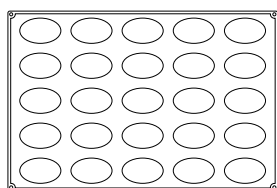

PX067
Oval

mm 85x50x43 h
~ 100 ml

25 impronte - indents

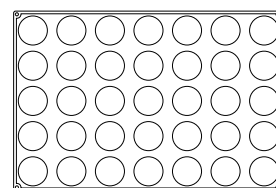

PX065
Kupola

Ø mm 60x58 h
~ 110 ml

35 impronte - indents

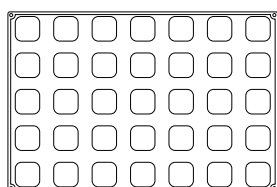

PX070
Tango

mm 50x50x58 h
~ 130 ml

35 impronte - indents

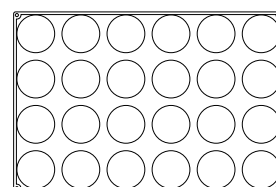

PX069
Levante

Ø mm 80x53 h
~ 110 ml

24 impronte - indents

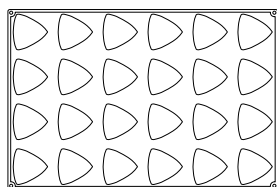

PX066
Trilo

mm 75x72x58 h
~ 96 ml

24 impronte - indents

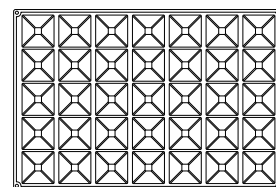

PX004
Piramide

mm 70x70x45 h
~ 80 ml

35 impronte - indents

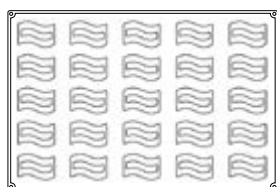

PX023
Ondina

mm 80x45x40 h
~ 130 ml

25 impronte - indents

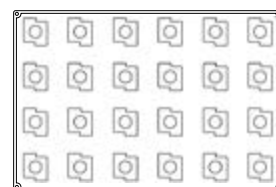

PX030
Tekno

mm 58x50x50 h
~ 115 ml

24 impronte - indents

Pavoflex 600x400 mm

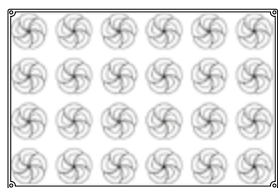

PX063
Spirale

Ø mm 75x38 h
~ 130 ml

24 impronte - indents

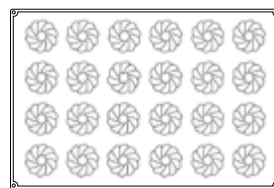

PX018
Fantasia

Ø mm 75x48 h
~ 120 ml

24 impronte - indents

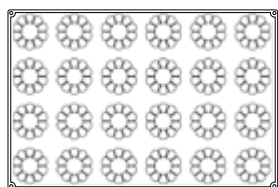

PX003
Briochette

Ø mm 79x37 h
~ 100 ml

24 impronte - indents

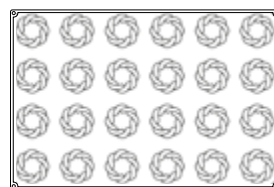

PX040
Intreccio

Ø mm 70x40 h
~ 130 ml

24 impronte - indents

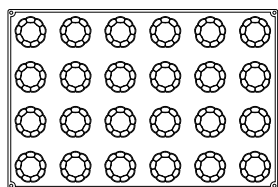

PX051
Charlotte

Ø mm 65x38 h
~ 105 ml

24 impronte - indents

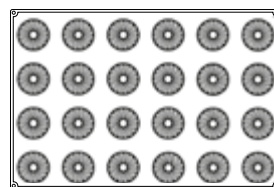

PX014
Guglhupf

Ø mm 70x33 h
~ 70 ml

24 impronte - indents

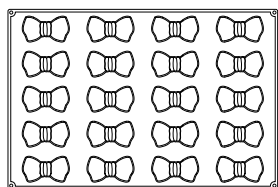

PX052
Papillon

mm 100x52x35 h
~ 105 ml

20 impronte - indents

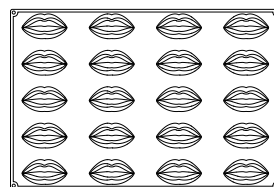

PX054
Bocca

mm 93x50x36 h
~ 105 ml

20 impronte - indents

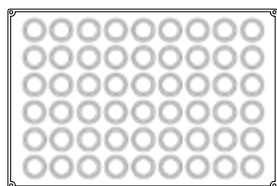

PX005
Mini Muffin

Ø mm 50x28 h
~ 45 ml

54 impronte - *indents*

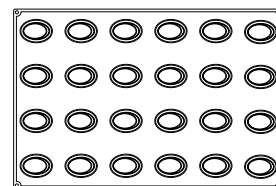

PX031*
Parentesi

mm 72x52x44 h
~ 100 ml

24 impronte - *indents*



PX035
Move

mm 120x35x36 h
~ 110 ml

20 impronte - *indents*

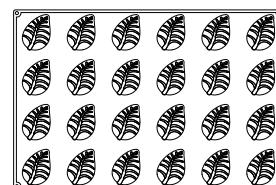

PX055
Foglia

mm 86x56x38 h
~ 105 ml

24 impronte - *indents*



PX015
Trittico

mm 120x32x32 h
~ 115 ml

20 impronte - *indents*

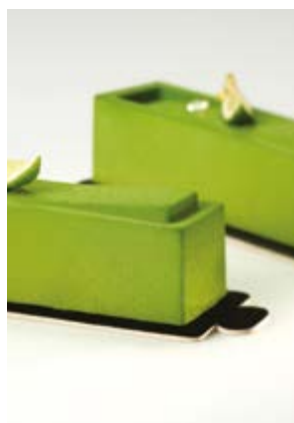

PX027
Libra

mm 120x30x35 h
~ 110 ml

20 impronte - *indents*



PX025
Soft

mm 120x32x38 h
~ 115 ml

20 impronte - *indents*



PX042
Twist

mm 122x32x33 h
~ 100 ml

20 impronte - *indents*

Pavoflex 600x400 mm



PX007
Cubo

mm 50x50x50 h
~ 115 ml

28 impronte - indents

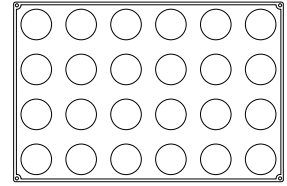

PX057
Cilindro

Ø mm 65x40 h
~ 130 ml

24 impronte - indents

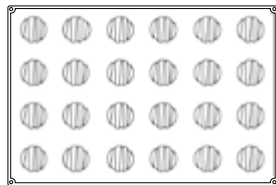

PX019
Rigo

Ø mm 60x45 h
~ 115 ml

24 impronte - indents

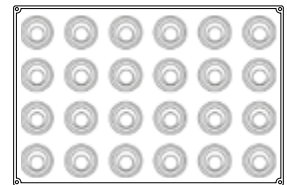

PX010
Babele

Ø mm 68x50 h
~ 130 ml

24 impronte - indents

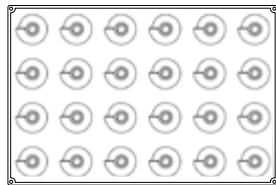

PX021
Cono

Ø mm 65x65 h
~ 125 ml

24 impronte - indents

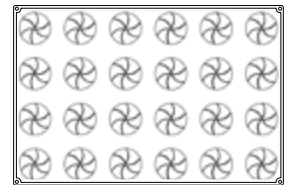

PX033
Vertigo

Ø mm 70x44 h
~ 110 ml

24 impronte - indents

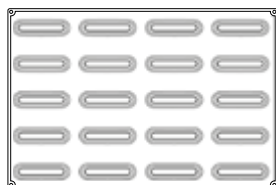

PX036
Round

mm 123x35x32 h
~ 100 ml

20 impronte - indents



PX026
Log

mm 120x30x32 h
~ 110 ml

20 impronte - indents

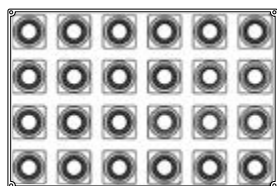

PX041
Caesar

mm 70x70x50 h
~ 130 ml

24 impronte - *indents*

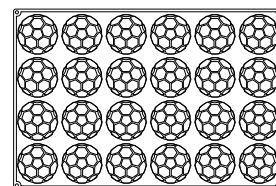

PX307
Pallone

Ø mm 80x45 h
~ 150 ml

24 impronte - *indents*

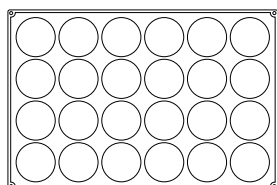

PX056
Big Muffin

Ø mm 85x50 h
~ 235 ml

24 impronte - *indents*



PX002
Muffin

Ø mm 70x40 h
~ 130 ml

24 impronte - *indents*

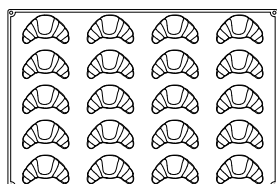

PX053*
Croissant

mm 100x60x36 h
~ 95 ml

20 impronte - *indents*

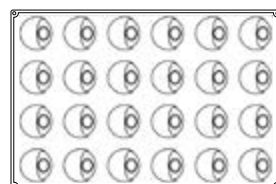

PX029
Eclisse

Ø mm 72x41 h
~ 110 ml

24 impronte - *indents*

*fino a esaurimento
subject to availability

Mignon







Pavoflex 400x300 mm

NEW

PX4378

Sfogliatella

by Giuseppe Amato

mm 45x43,5x22 h

~ 20 ml

30 impronte - indents

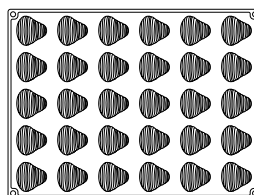



Pavoflex 400x300 mm

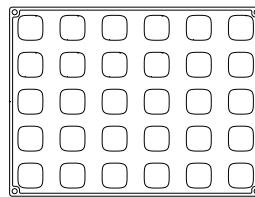

PX4346
Mister Mignon

mm 35x35x20 h
~ 18 ml

30 impronte - indents

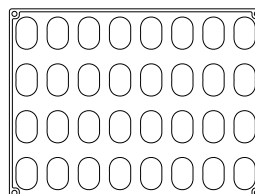

PX4348
Miss Mignon

mm 46x28x20 h
~ 18 ml

32 impronte - indents

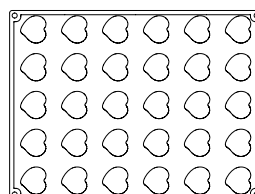

PX4325
Passion

mm 40x30x20 h
~ 18 ml

30 impronte - indents

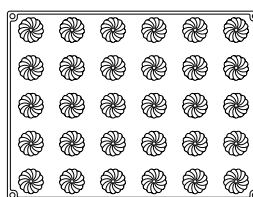

PX4324

Delice

Ø mm 36x29 h

~ 18 ml

30 impronte - indents

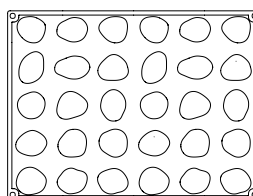

PX4326

Zen

dimensioni varie
different shapes

~ 18 ml

30 impronte - indents

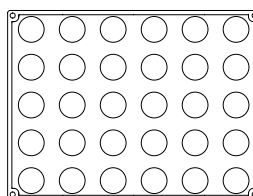

PX4323

Planet

Ø mm 38x20 h

~ 18 ml

30 impronte - indents

photo credits:
Richard Hawke



Pavoflex 600x400 mm

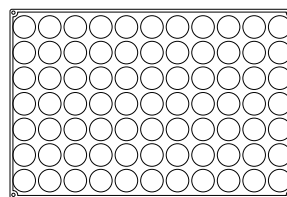

PX303 Semisfera

Ø mm 42x21 h
~ 20 ml

77 impronte - indents

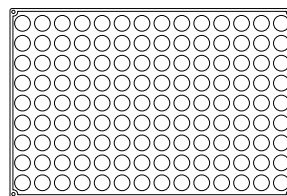

PX304 Semisfera

Ø mm 30x18 h
~ 10 ml

126 impronte - indents



Pavoflex 600x400 mm

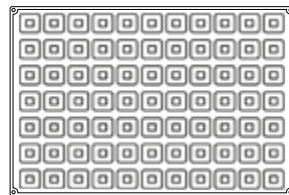

PX046
Savarin Mignon

mm 38x38x13 h
~ 14 ml

77 impronte - indents

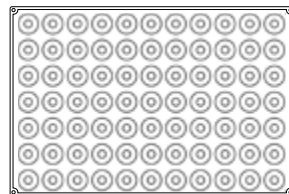

PX045
Savarin Mignon

Ø mm 40x13 h
~ 13 ml

77 impronte - indents

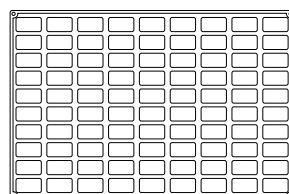

PX306
Mini Finanziere

mm 49x26x11 h
~ 11 ml

90 impronte - indents

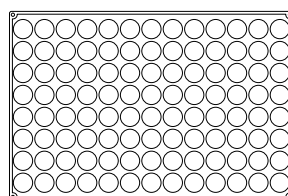

PX302
Pomponette

Ø mm 36x17 h
~ 15 ml

104 impronte - indents

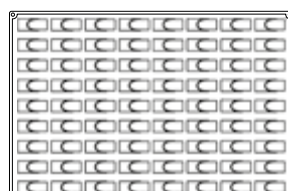

PX047
Flow Mignon

mm 60x24x23 h
~ 25 ml

72 impronte - indents



PX017
Intrigo Mignon

Ø mm 40x28 h
~ 25 ml

54 impronte - indents

Pavoflex 600x400 mm

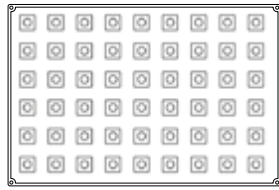

PX012
Cubo Mignon

mm 30x30x30 h
~ 25 ml

54 impronte - *indents*



PX013
Cilindro Mignon

Ø mm 35x35 h
~ 25 ml

54 impronte - *indents*

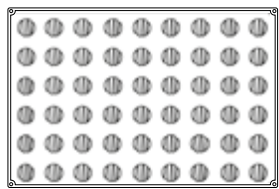

PX020
Rigo Mignon

Ø mm 35x30 h
~ 25 ml

54 impronte - *indents*

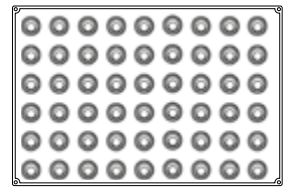

PX011
Babele

Ø mm 40x30 h
~ 25 ml

54 impronte - *indents*

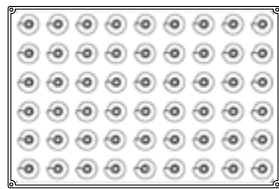

PX022
Cono Mignon

Ø mm 40x43 h
~ 30 ml

54 impronte - *indents*

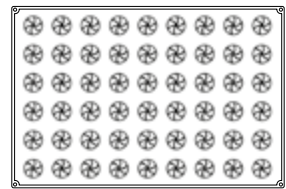

PX048
Vertigo Mignon

Ø mm 40x27 h
~ 25 ml

54 impronte - *indents*

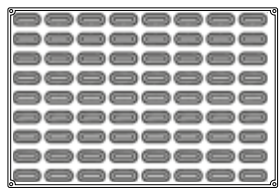

PX044
Round Mignon

mm 60x24x23 h
~ 25 ml

72 impronte - *indents*

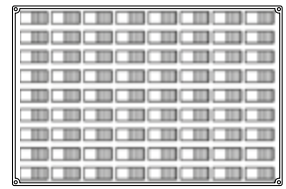

PX043
Log Mignon

mm 60x24x21 h
~ 29 ml

72 impronte - *indents*

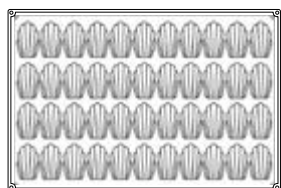

PX006
Madeleine

mm 78x45x18 h
~ 35 ml

44 impronte - indents

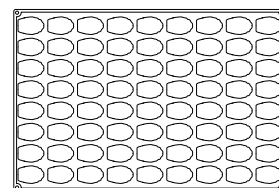

PX305
Mini Madeleine

mm 52x33x15 h
~ 15 ml

72 impronte - indents

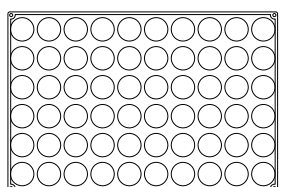

PX301
Mini Tartellette

Ø mm 48x15 h
~ 21 ml

60 impronte - indents

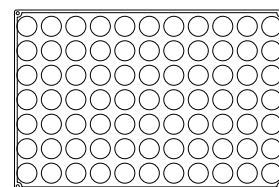

PX300
Petit Four

Ø mm 40x20 h
~ 22 ml

77 impronte - indents

Torte Cakes





Pavocake

NEW

KE062

Cyclone

by Emmanuele
Forcone

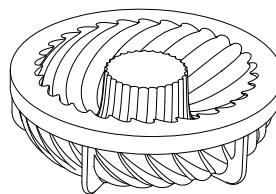

external Ø mm 180

internal Ø mm 55

mm 57 h

~ 1036 ml

Emmanuele Forcone x Pavocake

Tante idee per una pasticceria a colori. Dalla collaborazione fra Emmanuele Forcone, Campione del Mondo di Pasticceria, e Pavoni Italia nascono le Torte di Emmanuele, dallo straordinario effetto tridimensionale, e i TOPs, da interpretare in modo creativo sia in abbinamento alle torte che come spettacolari dessert al piatto.

So many ideas for a coloured pastry. The collaboration between Emmanuele Forcone, World Pastry Champion, and Pavoni Italia has led to the creation of Torte di Emmanuele with extraordinary 3D effects, and TOPs to be creatively interpreted both in combination with cakes and as spectacular plated desserts.

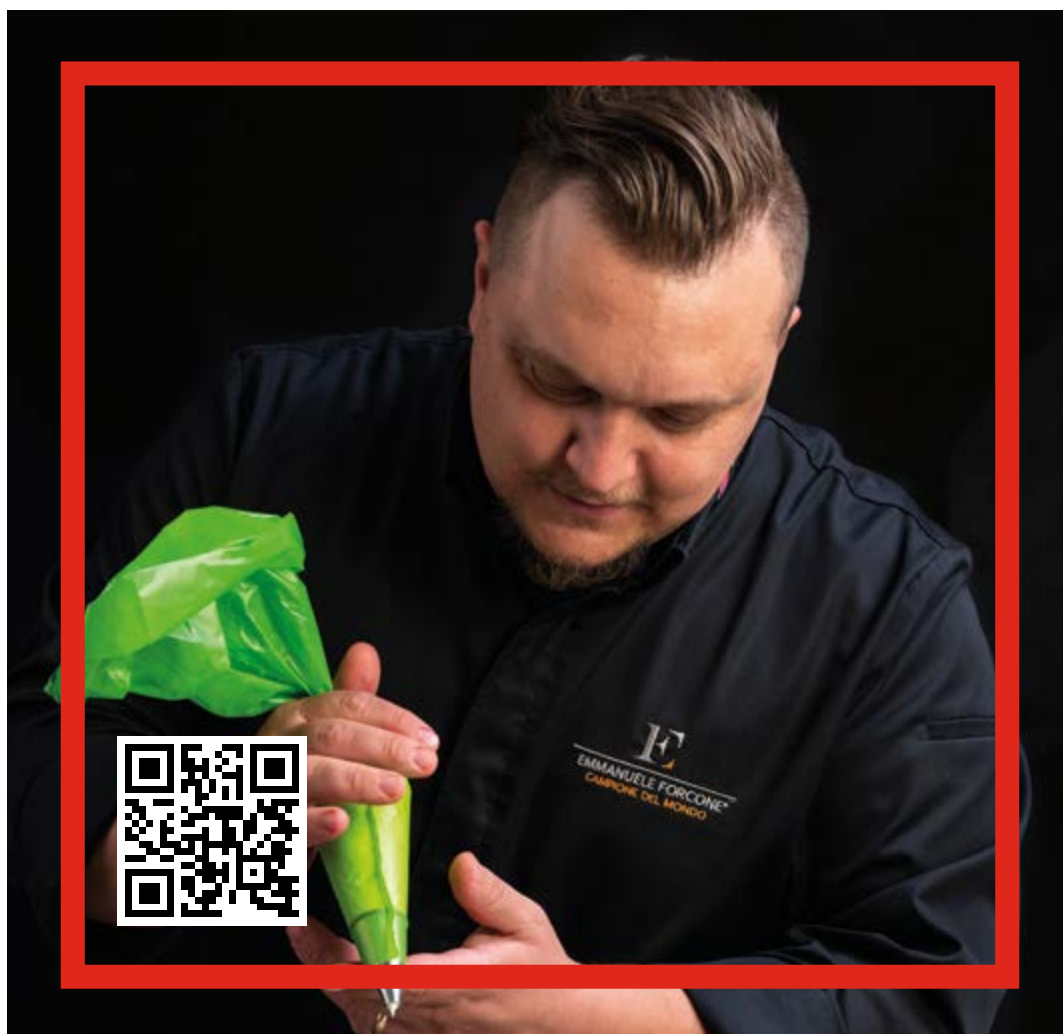

Guarda il video **Pavocake by Emmanuele Forcone** sul canale Youtube di Pavoni Italia
Watch the video **Pavocake by Emmanuele Forcone** on Pavoni Italia's Youtube channel

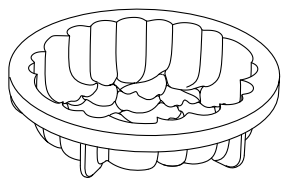

KE068

Eros

by Emmanuele
Forcone

NEW

mm 179x178x48 h
~ 1022 ml



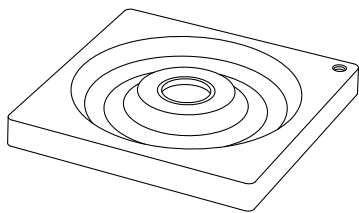

KE069S

Hula

by Emmanuele Forcone

Top external Ø mm 170
internal Ø mm 65
mm 21 h
~ 294 ml

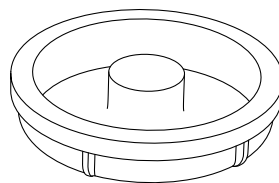

NEW

Base
external Ø mm 180
internal Ø mm 54
mm 40 h
~ 848 ml



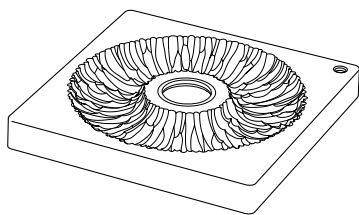

KE070S

Corolla

by Emmanuele Forcone

Top external Ø mm 171
 internal Ø mm 60
 mm 21 h
 ~ 269 ml

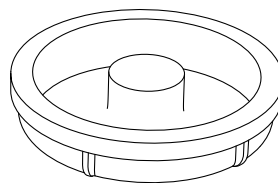

NEW

Base
 external Ø mm 180
 internal Ø mm 54
 mm 40 h
 ~ 848 ml



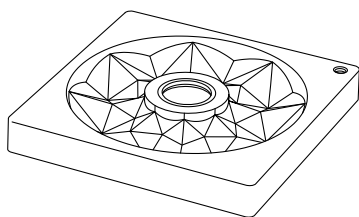

KE071S

Louvre

by Emmanuele Forcone

Top external Ø mm 170
internal Ø mm 60
mm 23 h
~ 256 ml

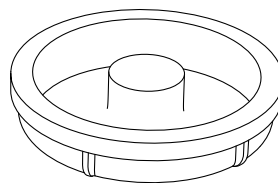

NEW

Base
external Ø mm 180
internal Ø mm 54
mm 40 h
~ 848 ml



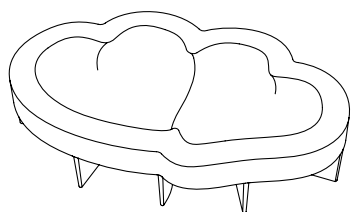

KE049S

Beloved

by Emmanuele
Forcone

mm 250x140x60 h
~ 1200 ml



coppapasta incluso
cutter *included*



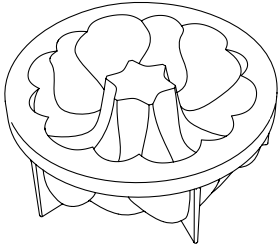

KE047

Nevada

by Emmanuele
Forcone

external Ø mm 180
internal Ø mm 36
mm 70 h
~ 1150 ml

abbinabile con inserimento:
can be combined with insert:

KE020

vedi pag - see page 257



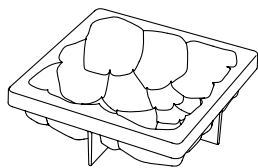

KE050

Ametista

by Emmanuele

Forcone

mm 165x165x50 h

~ 1000 ml



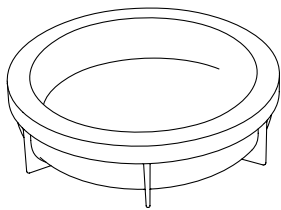

KE024

Planet

by Emmanuele
Forcone

Ø mm 180x45 h
~ 1000 ml

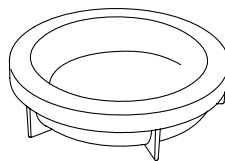

KE052

Mini Planet

by Emmanuele
Forcone

Ø mm 145x40 h
~ 600 ml



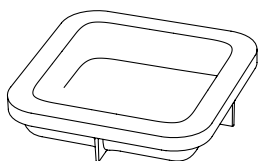

KE043

Mars

by Emmanuele
Forcone

mm 165x165x40 h
~ 1000 ml

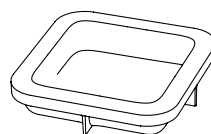

KE051

Mini Mars

by Emmanuele
Forcone

mm 135x135x37 h
~ 600 ml



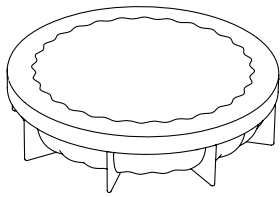

KE013

Plissée

by Emmanuele
Forcone

Ø mm 180x47 h
~ 1000 ml

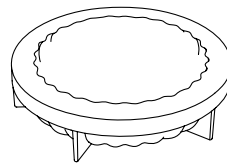

KE053

Mini Plissée

by Emmanuele
Forcone

Ø mm 145x40 h
~ 550 ml



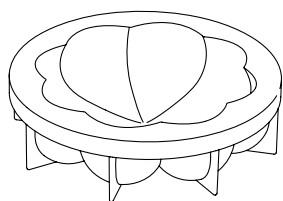

KE015

Bombée

by Emmanuele Forcone

Ø mm 180x50 h
~ 1000 ml

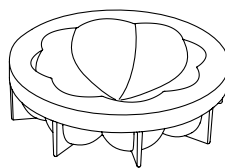

KE054

Mini Bombée

by Emmanuele Forcone

Ø mm 145x43 h
~ 550 ml





KE018

Queen

by Emmanuele Forcone

external Ø mm 180
internal Ø mm 52
mm 57 h
~ 1000 ml

abbinabile con
inserimento:
can be combined with
insert:

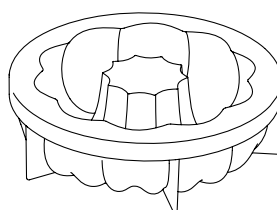

KE020

vedi pag - see page 257



KE019

Royal

by Emmanuele Forcone

external Ø mm 180
internal Ø mm 61
mm 57 h
~ 1000 ml

abbinabile con
inserimento:
can be combined with
insert:

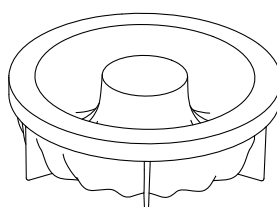

KE020

vedi pag - see page 257



KE032

Galaxy

by Emmanuele Forcone

external Ø mm 175
internal Ø mm 55
mm 55 h
~ 1000 ml

abbinabile con
inserimento:
can be combined with
insert:

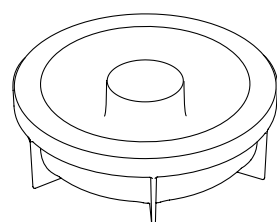

KE020

vedi pag - see page 257

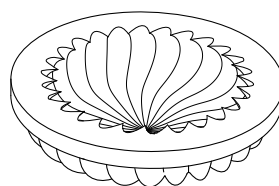

KE042
Flip

by Emmanuele
Forcone

Ø mm 180x45 h
~ 900 ml

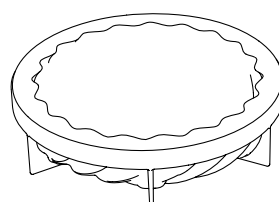

KE027
Caleidon

by Emmanuele
Forcone

Ø mm 180x45 h
~ 1000 ml

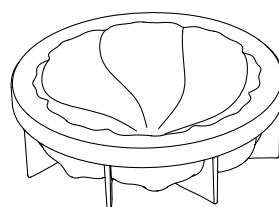

KE030
Twister

by Emmanuele
Forcone

Ø mm 180x50 h
~ 1000 ml

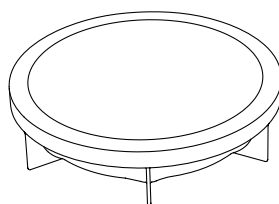

KE025

Classic

by Emmanuele
Forcone

Ø mm 180x45 h
~ 1000 ml

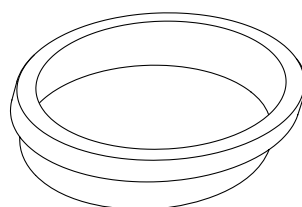

KE026

Windy

by Emmanuele
Forcone

mm 195x180x45 h
~ 1100 ml

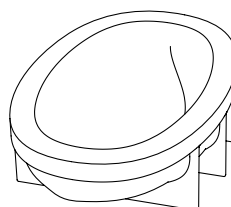

KE028

Curvy

by Emmanuele
Forcone

mm 200x130x65 h
~ 960 ml

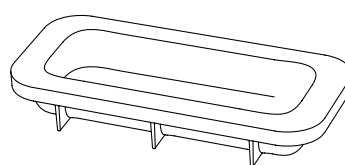

KE044
Venus

by Emmanuele
Forcone

mm 250x100x40 h
~ 900 ml

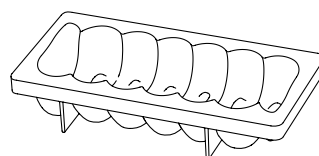

KE039
Honorè

by Emmanuele
Forcone

mm 230x105x45 h
~ 1000 ml

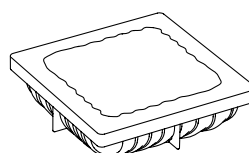

KE023
Pop

by Emmanuele
Forcone

mm 162x162x46 h
~ 1000 ml

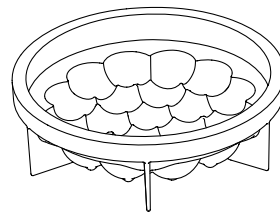

KE029

Puffy

by Emmanuele
Forcone

Ø mm 180x55 h
~ 1000 ml

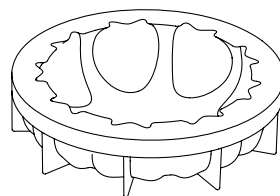

KE014

Petal

by Emmanuele
Forcone

Ø mm 180x47 h
~ 1000 ml

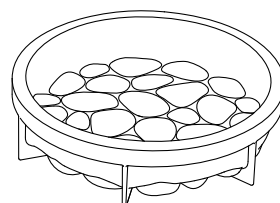

KE038

Rocky

by Emmanuele
Forcone

Ø mm 180x50 h
~ 1050 ml



KE016

Passion

by Emmanuele Forcone

mm 175x165x58 h
~ 960 ml

abbinabile con
inserimento:
can be combined
with insert:

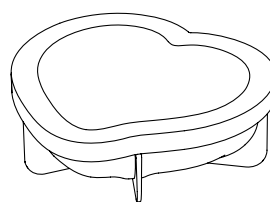

KE017

vedi pag - see
page 257



KE037

Square

by Emmanuele Forcone

external mm 150x150
internal mm 45x45
55 h
~ 1000 ml

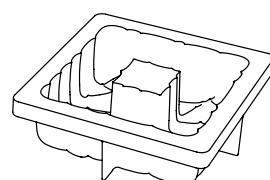

KE031

Top

by Emmanuele Forcone

Ø mm 180x45 h
~ 900 ml

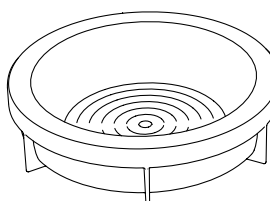

Karim Bourgi x Pavocake

Un'altra idea unica da uno dei più apprezzati pasticciere del panorama internazionale. Dopo Coin, Karim Bourgi, capo pasticciere di Alman Group, ha interpretato con Pavoni Italia Squeeze, una torta dalla trama unica: forme frastagliate e ricche, da interpretare e valorizzare in modo creativo attraverso colori e decorazioni eleganti.

Another unique idea from one of the most respected Pastry Chefs on the international scene. After Coin, Karim Bourgi – Head Pastry Chef of Alman Group – teamed up with Pavoni Italia to create Squeeze, a cake with a unique texture with irregular and complex shapes that can be creatively interpreted and enhanced with elegant colours and decorations.



Guarda il video **Pavocake by Karim Bourgi** sul canale Youtube di Pavoni Italia
Watch the video **Pavocake by Karim Bourgi** on Pavoni Italia's Youtube channel

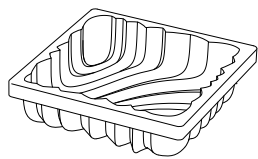

KE065
Squeeze
by Karim
Bourgi

NEW

mm 164x164x47 h
~ 1086 ml



Maurizio Santin x Pavocake

Disco è lo stampo in silicone essenziale e seducente sviluppato da Maurizio Santin con Pavoni Italia. La linea è minimale, aderente al credo "less is more". La perfezione è tutta nell'equilibrio di pochi elementi, che si valorizzano vicendevolmente: un cm di masticabilità, uno di caratterizzazione con inserto, uno di setosità e morbidezza. Tutta la forma che diventa sostanza, in soli 3 cm di eleganza.

Disco is the essential and seductive silicone mould developed by Maurizio Santin with Pavoni Italia. The line is minimal, according to his "less is more" belief. Perfection is in the balance of few elements which enhance each other: 1 cm of chewiness, 1 cm characterization with insert, 1 cm of smoothness. Shape becomes substance, 3 cm of pure elegance.



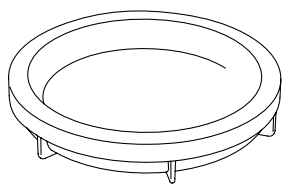

KE058

Disco

by Maurizio Santin

Ø mm 180x30 h

~ 720 ml



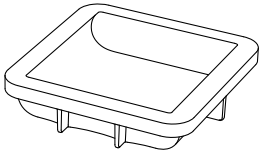

KE063
Jupiter

NEW

mm 167x158x40 h
~ 1006 ml



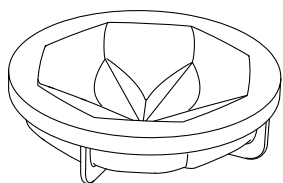

KE064
Sunny

NEW

Ø mm 180x50 h
~ 966 ml





Sapore orientale e gusto esotico. Singapore è lo stampo sviluppato da Pavoni Italia in collaborazione con la Nazionale di Pasticceria singaporiana, campione dell'Asian Pastry 2016. Un'idea di successo, che ha contribuito alla realizzazione della torta Choco-Fraise vincitrice della Coppa del Mondo 2017.

Oriental and exotic taste. Singapore is the mould developed by Pavoni Italia in collaboration with the Singaporean National Pastry team, 2016 Asian Pastry Champion. A successful idea, which helped the team in creating the Choco-Fraise winning cake of 2017 World Pastry Cup.

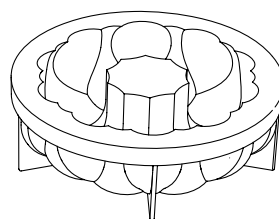

KE036
Singapore

external Ø mm 180
internal Ø mm 55
mm 60 h
~ 1000 ml

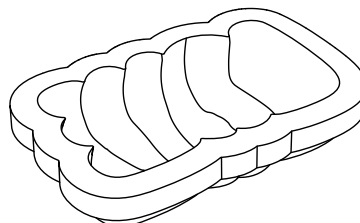

KE060
Lovely
by Antonio Bachour

mm 200x126x50 h
~ 1000 ml

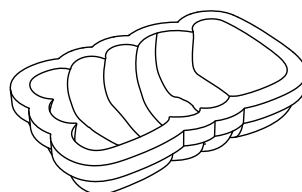

KE061
Lovely
by Antonio Bachour

mm 166x103x40 h
~ 550 ml



KE001

Ø mm 180x45 h
~ 900 ml

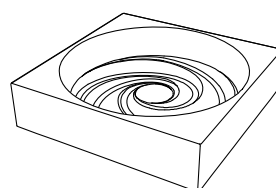

PK001

Kit 6 tortiere+
vassoio
6 cake moulds+
tray kit



KE002

Ø mm 180x45 h
~ 1135 ml

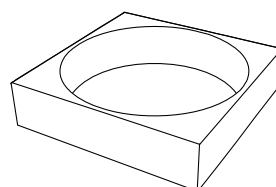

PK002

Kit 6 tortiere+
vassoio
6 cake moulds+
tray kit



KE003

Ø mm 180x60 h
~ 1140 ml

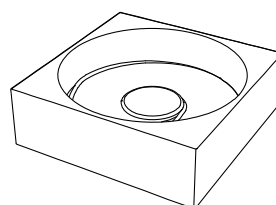

PK003

Kit 6 tortiere+
vassoio
6 cake moulds+
tray kit



KE004

Ø mm 180x45 h
~ 920 ml

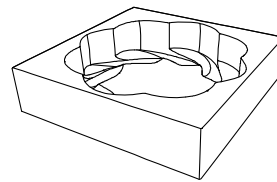

PK004

Kit 6 tortiere+
vassoio
6 cake moulds+
tray kit



KE005

Ø mm 180x45 h
~ 1000 ml

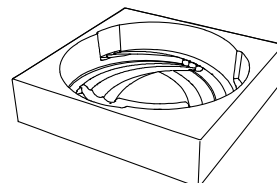

PK005

Kit 6 tortiere+
vassoio
6 cake moulds+
tray kit



KE006

Ø mm 180x55 h
~ 1150 ml

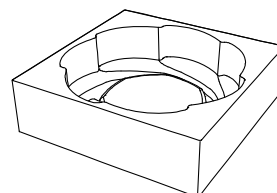

PK006

Kit 6 tortiere+
vassoio
6 cake moulds+
tray kit



KE007

Ø mm 180x90 h
~ 1527 ml

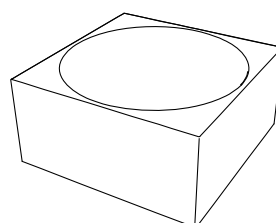

PK007

Kit 6 tortiere+
vassoio
6 cake moulds+
tray kit



KE008

Ø mm 180x90 h
~ 1330 ml

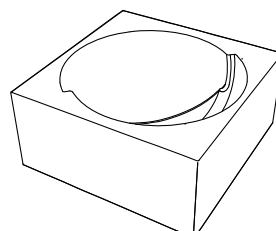

PK008

Kit 6 tortiere+
vassoio
6 cake moulds+
tray kit



KE009

Ø mm 180x90 h
~ 1540 ml

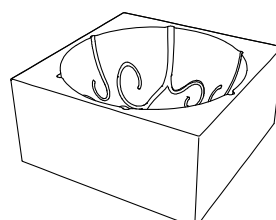

PK009

Kit 6 tortiere+
vassoio
6 cake moulds+
tray kit

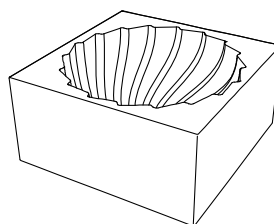

KE010

Ø mm 180x90 h
~ 1440 ml

PK010

Kit 6 tortiere+
vassoio
6 cake moulds+
tray kit

How to use



1. Riempi lo stampo con le tue preparazioni
2. Smodella con attenzione partendo dagli angoli
3. Completa lo smodellaggio dopo aver appoggiato la torta su di una superficie piana.

1. Fill the mould with your own mixtures
2. Carefully remove the cake from the mould by the corners
3. Remove completely from the mould after placing the cake on a flat surface.



Guarda i video sul canale Youtube di Pavoni Italia
Watch the videos on Pavoni Italia's Youtube channel

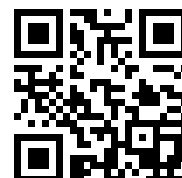

Stampi inserti per torte Moulds for inserts

Un utile aiuto per la realizzazione di inserti di differente tipologia destinati alle tue torte. Diversi formati, da 120 a 180 mm.

A useful aid for creating inserts of different types for your cakes. Various sizes, from 120 to 180 mm.

Pavocake

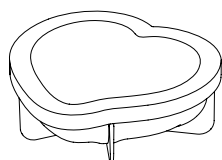

KE017

mm 150x140x50 h
~ 600 ml

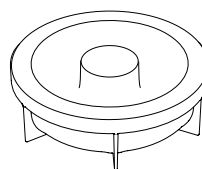

KE020

Ø est. mm 153
Ø int. mm 78
mm 44 h
~ 520 ml

Pavoflex 600x400 mm

Utilizzabili anche come stampi per torte.

They can be used also as cake moulds.

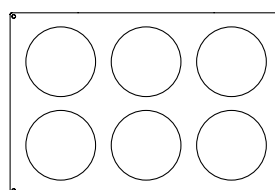

PX061

Ø mm 160x30 h
6 impronte - indents

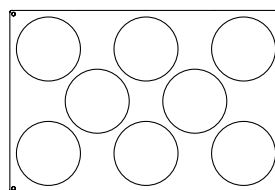

PX076

Ø mm 140x30 h
8 impronte - indents

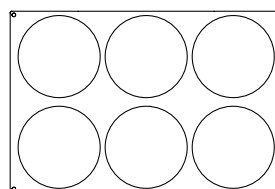

PX075

Ø mm 180x30 h
6 impronte - indents

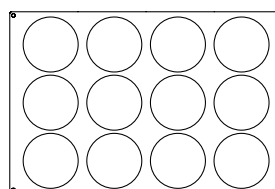

PX077

Ø mm 120x30 h
12 impronte - indents



Top



Guarda il video dedicato ai **Top by Emmanuele Forcone** sul canale Youtube di Pavoni Italia

Watch the video **Top by Emmanuele Forcone** on the Pavoni Italia's Youtube channel

Emmanuele Forcone x Top

Una linea di stampi in silicone per creare decorazioni uniche capaci di valorizzare ogni creazione con giochi di volumi e texture.

A brand new line of silicone moulds to enhance any creation with an interplay of volumes and textures.

TOP07

Ipnosi

by Emmanuele Forcone

dim stampo - mould
mm 300x175

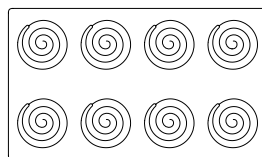

Ø mm 60x10 h
~ 30 ml

abbinabile a - can be
combined with **PX078**

TOP05

Ipnosi

by Emmanuele Forcone

dim stampo - mould
mm 300x175

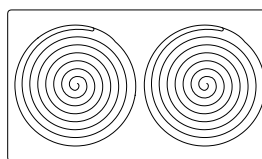

Ø mm 140x10 h
~ 125 ml

abbinabile alle fasce di pag
149 e a **KE024** - combined
with bands at page 149
and **KE024**

TOP06

Ipnosi

by Emmanuele Forcone

dim stampo - mould
mm 190x190

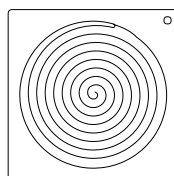

Ø mm 160x10 h
~ 185 ml

abbinabile alle fasce di pag
149 - combined with bands
at page 149

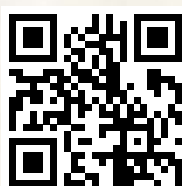

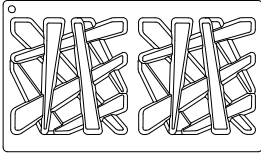

TOP13

Shanghai

by Emmanuele Forcone

dim stampo - mould
mm 300x175

mm 135x135x10 h
~ 88 ml

abbinabile a - can be
combined with **KE043**

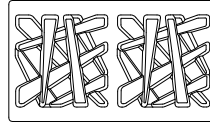

TOP14

Mini Shanghai

by Emmanuele Forcone

dim stampo - mould
mm 240x140

mm 107x107x8 h
~ 45 ml

abbinabile a - can be
combined with **KE051**



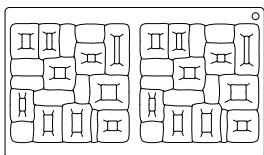

TOP01

Maya

by Emmanuele Forcone

dim stampo - mould
mm 300x175

mm 135x135x7 h
~ 90 ml

abbinabile a - can be
combined with **KE043**

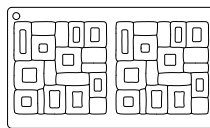

TOP12

Mini Maya

by Emmanuele Forcone

dim stampo - mould
mm 240x140

mm 107x107x7 h
~ 58 ml

abbinabile a - can be
combined with **KE051**



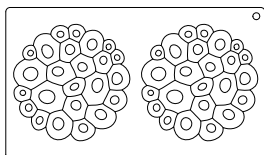

TOP09

Coral

by Emmanuele Forcone

dim stampo - mould
mm 300x175

Ø mm 135x15 h
~ 90 ml

abbinabile a - can be
combined with **KE024**

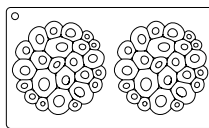

TOP10

Mini Coral

by Emmanuele Forcone

dim stampo - mould
mm 240x140

Ø mm 110x10 h
~ 45 ml

abbinabile a - can be
combined with **KE052**



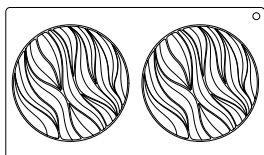

TOP08

River

by Emmanuele Forcone

dim stampo - mould
mm 300x175

Ø mm 135x15 h
~ 110 ml

abbinabile a - can be
combined with **KE024**

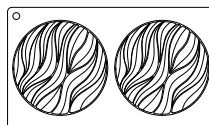

TOP11

Mini River

by Emmanuele Forcone

dim stampo - mould
mm 240x140

Ø mm 110x12 h
~ 58 ml

abbinabile a - can be
combined with **KE052**



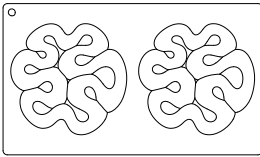

TOP15

Jelly

by Emmanuele Forcone

dim stampo - mould
mm 300x175

Ø mm 135x14 h
~ 90 ml

abbinabile a - can be
combined with **KE024**

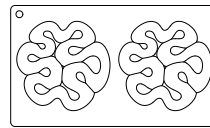

TOP16

Mini Jelly

by Emmanuele Forcone

dim stampo - mould
mm 240x140

Ø mm 110x11 h
~ 50 ml

abbinabile a - can be
combined with **KE052**





TOP02

Sponge

by Emmanuele Forcone

dim stampo - mould
mm 300x175

mm 135x135x10 h
~ 80 ml

abbinabile a - can be
combined with **KE043**

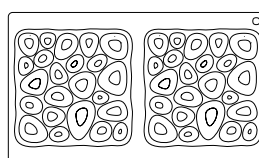

TOP04

Circle

by Emmanuele Forcone

dim stampo - mould
mm 240x175

mm 210x70x9 h
~ 90 ml

abbinabile a - can be
combined with **KE044**

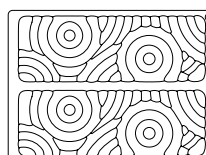

TOP03

Iceberg

by Emmanuele Forcone

dim stampo - mould
mm 240x175

mm 210x70x14 h
~ 100 ml

abbinabile a - can be
combined with **KE044**

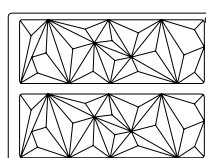

Tronchetti Logs





Pavocake

NEW

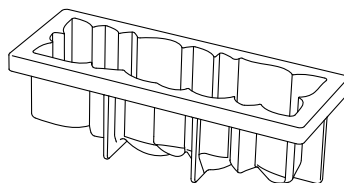

KE067
Acanto

mm 251x83x79 h
~ 1250 ml

KE066
Sequoia

mm 250x92x74 h
~ 1186 ml

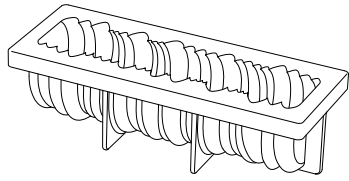

NEW



KE045**Coin**

by Karim Bourgi

mm 250x80x77 h

~ 1200 ml

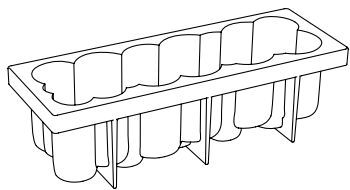

KE033

Bilbao

by Emmanuele
Forcone

mm 250x85x75 h
~ 1150 ml

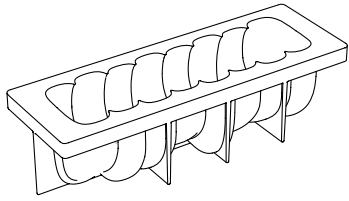

KE041

Atomic

by Emmanuele
Forcone

mm 250x80x80 h
~ 1200 ml

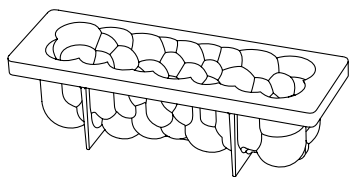

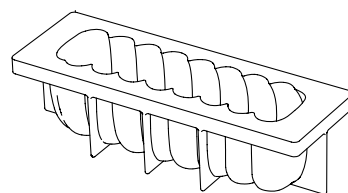

KE022

Crème

by Emmanuele Forcone

mm 250x84x75 h
~ 1000 ml

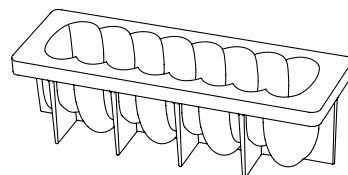

KE040

Canyon

by Emmanuele Forcone

mm 250x85x80 h
~ 1150 ml

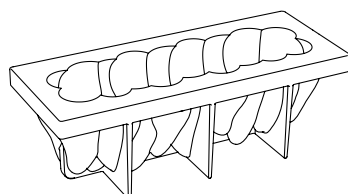

KE046

Anemone

mm 250x90x85 h
~ 1050 ml

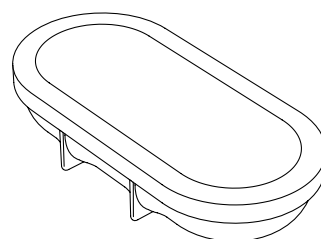

KE034

Futura

by Emmanuele Forcone

mm 230x100x45 h
~ 850 ml

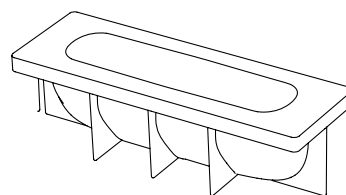

KE021

Sublime

by Emmanuele Forcone

mm 250x80x80 h
~ 1000 ml

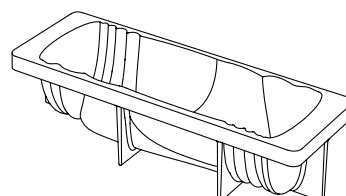

KE035

Lady

by Emmanuele Forcone

mm 250x90x75 h
~ 1150 ml

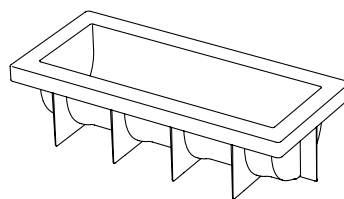

KE012
Bûche

mm 250x85x70 h
~ 1240 ml

abbinabile con
inserimento:
can be combined
with insert:

KE011
vedi sotto
see below

Stampi inserti per tronchetti Moulds for inserts

Il modo più semplice e veloce per creare gustosi inserimenti per tronchetti, attraverso semplici riempimenti da finalizzare in forno o porre in abbattitore.

The easiest and quickest way to create tasty inserts for logs, thanks to simple moulds suitable for both oven and blast chiller.

Pavocake

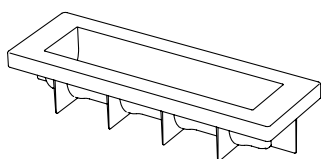

KE011

mm 230x55x50 h
~ 540 ml

Texture per tronchetti Textures for logs

Rendi il tuo tronchetto una creazione davvero unica! Con le texture in silicone Pavoni Italia, otterrai una decorazione veloce e di grande effetto.

Make your log a truly unique creation! You'll get fast and impressive decorations with these silicone mats.

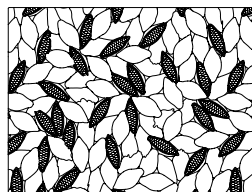
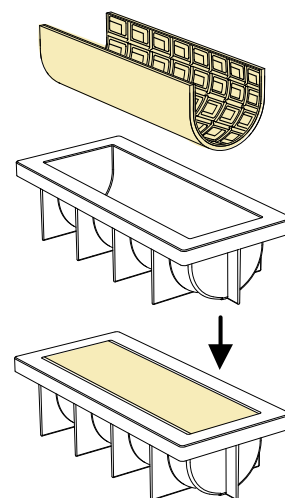

TX01
Cabosse

mm 250x190
utilizzabile con -
to be used with
KE012

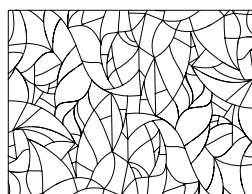

TX02
Sauvage

mm 250x190
utilizzabile con -
to be used with
KE012

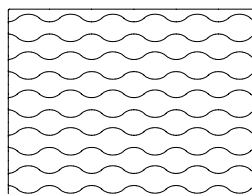

TX03
Rollé

mm 250x190
utilizzabile con -
to be used with
KE012

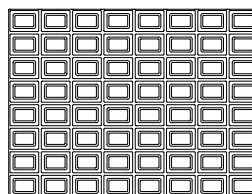

TX04
Chocolat

mm 250x190
utilizzabile con -
to be used with
KE012

Tronchetti porzionabili *Portionable logs*



Pavoflex 400x300 mm

PX4320*
Plummy

mm 360x50x36 h
~ 410 ml

5 impronte - indents

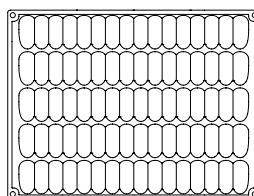

abbinabile con
inserimento - can be
combined with insert:

PX058

vedi pag - see page 279



*fino a esaurimento
subject to availability

Pavoflex 400x300 mm

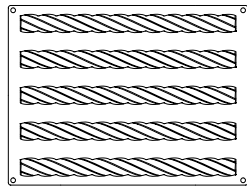

PX4309*

Candy

mm 360x39x35 h
~ 360 ml

5 impronte - indents

abbinabile con
inserimento - can be
combined with insert:

PX058

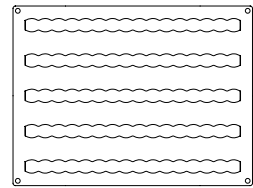

PX4310*

Soft

mm 360x43x38 h
~ 360 ml

5 impronte - indents

abbinabile con
inserimento - can be
combined with insert:

PX058

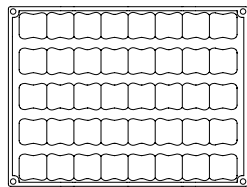

PX4318*

Bamboo

mm 360x40x38 h
~ 400 ml

5 impronte - indents

abbinabile con
inserimento - can be
combined with insert:

PX058

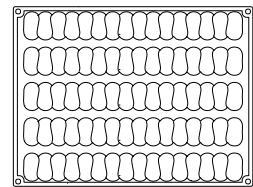

PX4319*

Dada

mm 360x42x37 h
~ 420 ml

5 impronte - indents

abbinabile con
inserimento - can be
combined with insert:

PX058

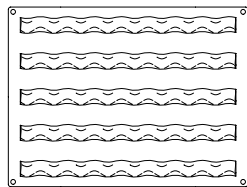

PX4311*

Volupté

mm 360x41x37 h
~ 360 ml

5 impronte - indents

abbinabile con
inserimento - can be
combined with insert:

PX058

*fino a esaurimento
subject to availability



Pavoflex 600x400 mm

PX060 Tronchetto Mono

Ø mm 40x560
~ 600 ml

5 impronte - indents

abbinabile con
inserimento - can be
combined with insert:

PX058

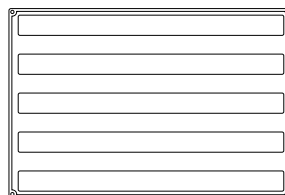

PX059 Tronchetto

mm 560x80x63 h
~ 2376 ml

4 impronte - indents

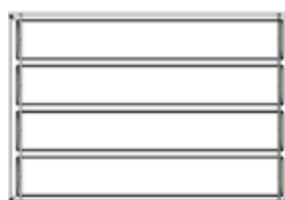

Stampi inserti per tronchetti Moulds for inserts

Prepara in modo semplice e veloce gli inserti per i tuoi tronchetti porzionabili, da finalizzare in forno o in abbattitore.

Quickly and easily prepare the inserts for your portionable logs, to be finished in the oven or in a blast chiller.

Pavoflex 600x400 mm

PX058 Tronchetto Mignon

Ø mm 18x560
~ 124 ml

9 impronte - indents

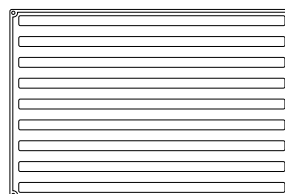

Sphere





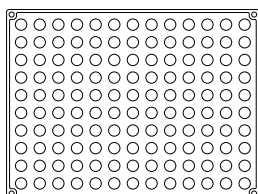

photo credits: Fabrizio Fiorani

Pavoflex 400x300 mm

Dimensioni diverse, da 15 a 60 mm di diametro, per preparare sezioni di sfere da decorare e utilizzare per impreziosire le tue preparazioni.

Various sizes, from 15 to 60 mm in diameter, to prepare sections of spheres that you can decorate and use to embellish your creations.



PX4339

Ø mm 15
~ 2 ml

130 impronte - indents

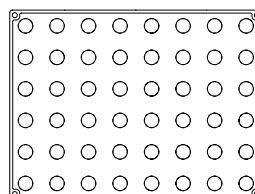

PX4314

Ø mm 20
~ 4 ml

48 impronte - indents

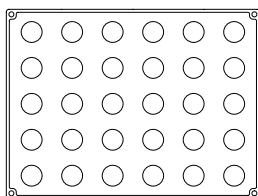

PX4313

Ø mm 30
~ 14 ml

30 impronte - indents

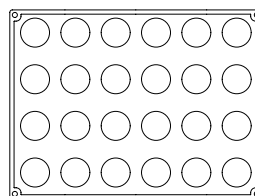

PX4315

Ø mm 40
~ 33 ml

24 impronte - indents

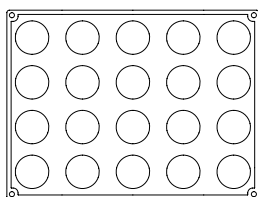

PX4316

Ø mm 50
~ 65 ml

20 impronte - indents

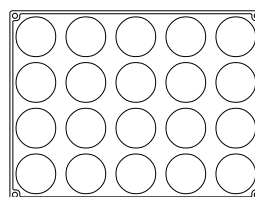

PX4350

Ø mm 60
~ 110 ml

20 impronte - indents



Pavoduo 300x175 mm

Stampi in due parti per la preparazione di sfere perfette, da 25 a 55 mm di diametro. L'effetto 3D è totale, grazie alla concezione innovativa dello stampo, per sfere davvero "a tutto tondo".

Two-part moulds for the preparation of perfect spheres, from 25 to 55 mm in diameter. The 3D effect is complete, thanks to the innovative design of the mould, for truly "all-round" spheres.



AF001

Ø mm 55
~ 87 ml
8 impronte - indents

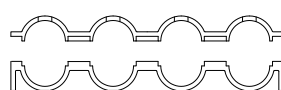
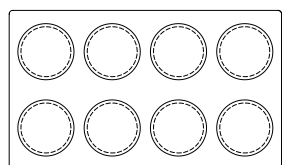

AF002

Ø mm 45
~ 48 ml
11 impronte - indents

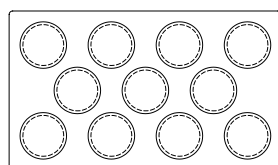

AF003

Ø mm 35
~ 22,5 ml
18 impronte - indents

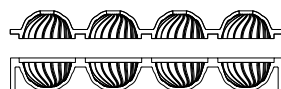
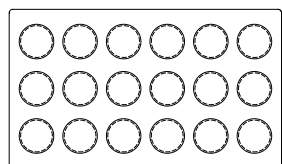

AF004

Ø mm 55
~ 83 ml
8 impronte - indents

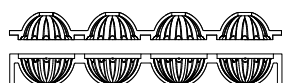
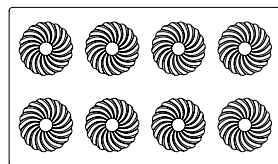

AF005

Ø mm 55
~ 80 ml
8 impronte - indents

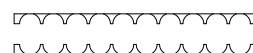
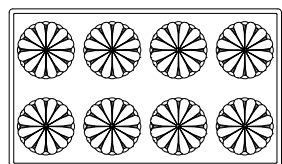

LS05

Ø mm 25
~ 8 ml
67 impronte - indents
Dim. stampo - mould
mm 290x190

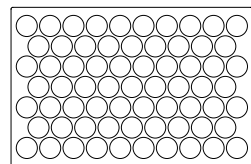

Quenelle



Pavoflex 600x400 mm

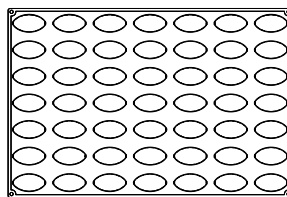

PX071
Quenelle

mm 66x33x30 h
~ 32 ml

49 impronte - indents

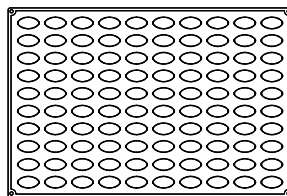

PX072
Mini Quenelle

mm 42x20x20 h
~ 8 ml

100 impronte - indents

Pavoflex 600x400 mm

PX073

Quenelle Tonda

mm 66x35x26 h
~ 34 ml

49 impronte - indents

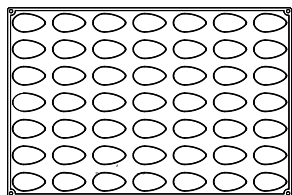

PX074

Mini Quenelle Tonda

mm 42x22x17 h
~ 9 ml

100 impronte - indents

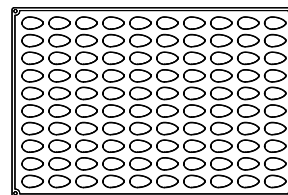

Pavoflex 400x300 mm

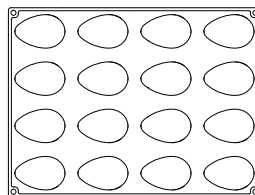

PX4369
Mono Quenelle

mm 77x51x42 h
~ 90 ml

16 impronte - indents



Éclair Mania



pavon



Formasil Éclair

Tappetini in silicone microforato e antiaderente con impronte per éclair. I microfori facilitano la distribuzione ottimale del calore e permettono all'impasto di aggrapparsi per uno sviluppo in altezza e una perfetta cottura del prodotto. Le sagome sul tappetino costituiscono un'utile guida per un utilizzo ideale.

Micro-perforated and non-stick silicone mats with éclair indents. The micro-perforations facilitate the optimal distribution of heat and allow the dough to grip on for optimal rising and the perfect baking of the product. The outlines on the mat provide a useful guide for ideal use.

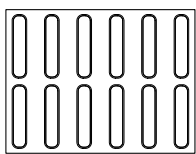

FF4313

mm 125x25x5 h
12 impronte - indents

Dim. stampo - mould
mm 400x300

NEW

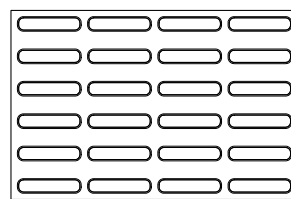

FF13

mm 125x25x5 h
24 impronte - indents

Dim. stampo - mould
mm 600x400

Forosil Éclair

Tappetini in silicone microforato e antiaderente, sagomati e progettati per la preparazione semplice e versatile di éclair. La distribuzione ottimale del calore è garantita dai microfori, che permettono all'impasto uno sviluppo in altezza e una perfetta cottura del prodotto.

Micro-perforated and non-stick silicone mats, shaped and designed for the simple and versatile preparation of éclairs. The micro-perforations guarantee the optimal distribution of heat and allow optimal rising and the perfect baking of the product.

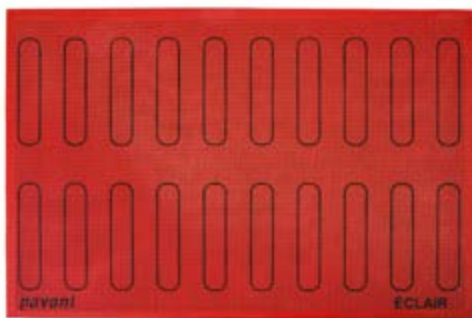

ECL20

mm 125x25
20 impronte - indents

Dim. stampo - mould mm 600x400

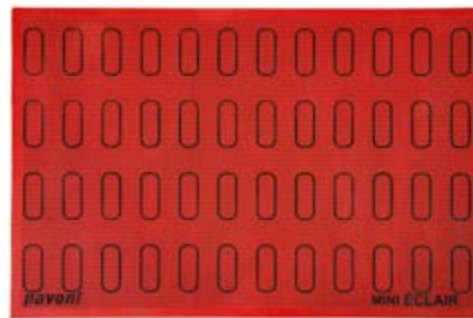

ECL48

mm 60x18
48 impronte - indents

Dim. stampo - mould mm 600x400

Teglia microforata - Micro-perforated tray

Con i suoi microfori la teglia permette una migliore distribuzione del calore e una cottura ottimale del prodotto finito. È il completamento perfetto da abbinare al tappetino éclair.

With its micro holes the tray allows a better distribution of the heat, together with an optimal baking of the finished product. This is the best complement to match the éclairs mat.



JF06040D20P00G

mm 600x400x20 h

How to use

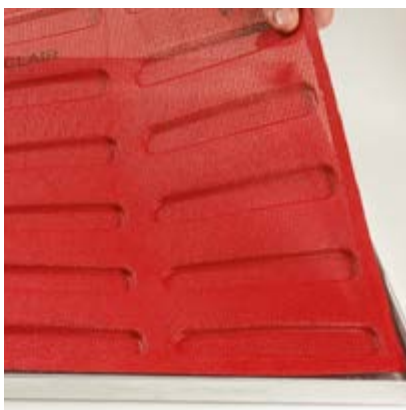

1. Appoggia il tappetino Formasil Éclair su una teglia microforata
2. Riempi le impronte con il preparato aiutandoti con un sac à poche
3. Metti in forno per una cottura e sviluppo in altezza perfetti del preparato.

1. Place the Éclair Formasil mat on a micro-perforated baking tray
2. Fill the indents with your mixture with a piping bag
3. Place in the oven for the perfect rising and baking of your creation.

Formasil





Flessibili, multiuso, creativi. I tappetini microforati Formasil, sviluppati in collaborazione con Leonardo di Carlo, consentono di unire fantasia e razionalità, con infinite variabili e combinazioni, dolci e salate. Con un grande vantaggio: Formasil regala una cottura uniforme anche dei prodotti da forno che faticano a cuocere, assicurando un'alta resa di produzione, il corretto sviluppo della lievitazione in altezza e forme sempre perfette.

Flexible, multipurpose, and creative. The Formasil micro-perforated mats, developed in collaboration with Leonardo di Carlo, allow professionals to match their creativity with rationality, with infinite variations and combinations, for both sweet and savoury dishes. With one huge advantage: Formasil delivers uniform cooking even with difficult to bake goods, ensuring a high production yield, for baked goods that rise to the right height and in the perfect shapes every time.



Leonardo Di Carlo x Formasil

Dalla passione e motivazione per risvegliare la pasticceria e non solo dal sonno dogmatico della ricetta nasce Formasil. Leonardo Di Carlo, Campione del mondo di pasticceria, ribalta insieme a Pavoni Italia i preconetti e le mappe mentali del lavoro in cucina, per un prodotto versatile, creativo e funzionale.

From passion and motivation to revitalising pastry making, and from more than just the dogmatic slumber of the recipes, comes Formasil. Leonardo Di Carlo – World Champion Pastry Chef – together with Pavoni Italia, overturns the preconceptions and mind maps of working in the kitchen, in order to design a versatile, creative and functional product.



Guarda il video **Formasil** sul canale Youtube di Pavoni Italia

Watch the video **Formasil** on Pavoni Italia's Youtube channel



Formasil 400x300 mm

FF4306

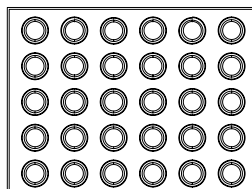

Ø sup mm 40
Ø inf mm 32
mm 16 h
~ 16 ml

30 impronte - indents



FF4301

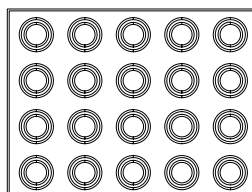

Ø sup mm 48
Ø inf mm 36
mm 16 h
~ 22 ml

20 impronte - indents



FF4308

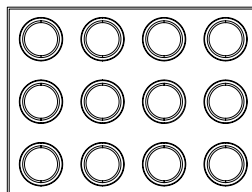

Ø sup mm 65
Ø inf mm 55
mm 20 h
~ 57 ml

12 impronte - indents

FF4311

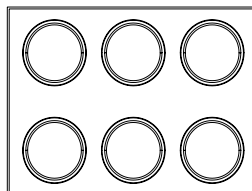

Ø sup mm 100
Ø inf mm 90
mm 20 h
~ 140 ml

6 impronte - indents



Formasil 400x300 mm

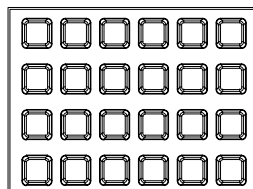

FF4303

sup dim mm 45x45
 inf dim mm 37x37
 mm 16 h
 ~ 27 ml
 24 impronte - indents

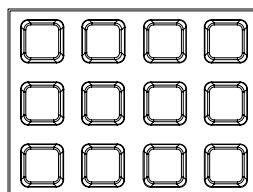

FF4304

sup dim mm 65x65
 inf dim mm 55x55
 mm 20 h
 ~ 71 ml
 12 impronte - indents

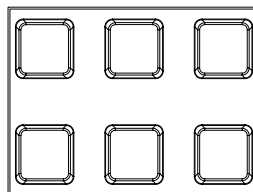

FF4302

sup dim mm 85x85
 inf dim mm 75x75
 mm 20 h
 ~ 127 ml
 6 impronte - indents

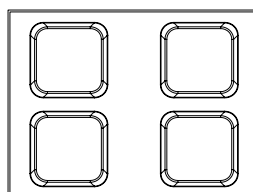

FF4305

sup dim mm 120x120
 inf dim mm 106x106
 mm 30 h
 ~ 374 ml
 4 impronte - indents



Formasil 600x400 mm

FF06

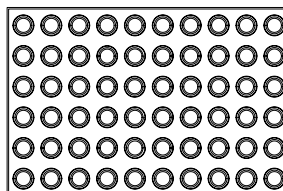

Ø sup mm 40
Ø inf mm 32
mm 16 h
~ 16 ml

60 impronte - indents



FF01

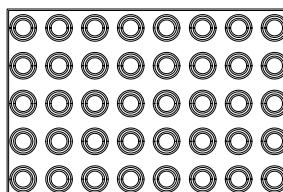

Ø sup mm 48
Ø inf mm 36
mm 16 h
~ 22 ml

40 impronte - indents



FF08

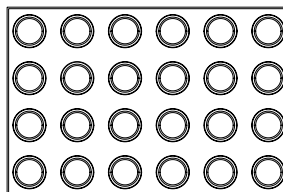

Ø sup mm 65
Ø inf mm 55
mm 20 h
~ 57 ml

24 impronte - indents

FF09

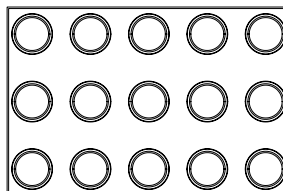

Ø sup mm 80
Ø inf mm 70
mm 20 h
~ 88 ml

15 impronte - indents



Formasil 600x400 mm

FF11

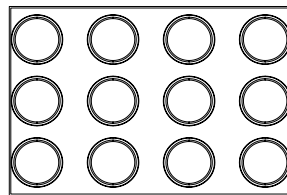

Ø sup mm 100
Ø inf mm 90
mm 20 h
~ 140 ml

12 impronte - indents



FF10

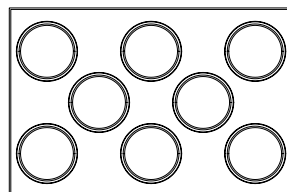

Ø sup mm 120
Ø inf mm 110
mm 30 h
~ 332 ml

8 impronte - indents



FF12

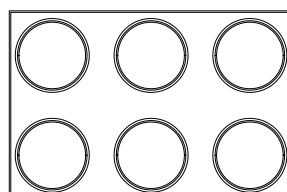

Ø sup mm 150
Ø inf mm 140
mm 30 h
~ 495 ml

6 impronte - indents

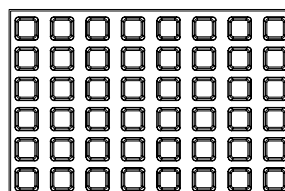

FF03

sup dim mm 45x45
 inf dim mm 37x37
 mm 16 h
 ~ 27 ml
 48 impronte - indents

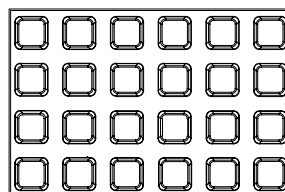

FF04

sup dim mm 65x65
 inf dim mm 55x55
 mm 20 h
 ~ 71 ml
 24 impronte - indents

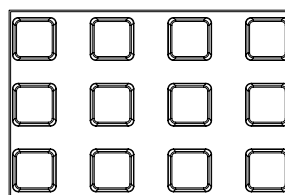

FF02

sup dim mm 85x85
 inf dim mm 75x75
 mm 20 h
 ~ 127 ml
 12 impronte - indents

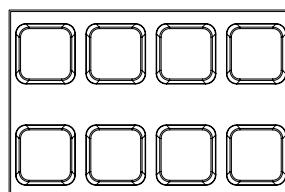

FF05

sup dim mm 120x120
 inf dim mm 106x106
 mm 30 h
 ~ 374 ml
 8 impronte - indents

Formaflex





Formaflex 300x175 mm

Forme creative geometriche tra cui scegliere, per realizzare monoporzioni e mignon dolci e salate. Un unico formato, da 300x175 mm, esattamente pari ad un terzo di Gastronorm e a un quarto delle classiche teglie da pasticceria, per garantire la massima produttività e la migliore compatibilità con le attrezzature professionali. Formaflex è resistente da -40°C a + 250°C.

Choose from creative geometric shapes to create sweet and savoury single-serving portions and mignons. One 300x175 mm size mould, exactly equal to one third of Gastronorm trays and one quarter of the classic pastry trays, to guarantee maximum productivity and the best compatibility with professional equipment. Formaflex can withstand temperatures from -40°C to +250°C.

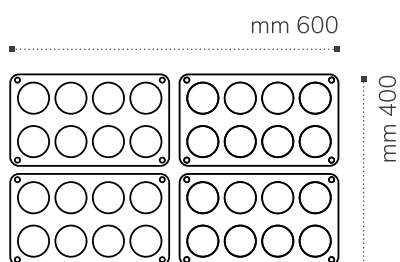
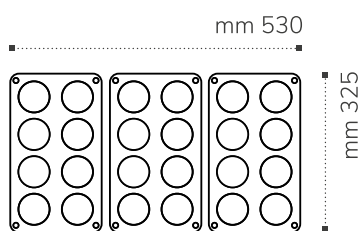
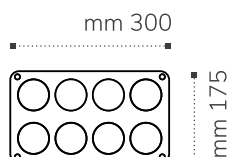



FR073
Micro savarin tondo

Ø mm 30x13,5 h
~ 7,5 ml
28 impronte - indents



FR074
Micro savarin ovale

mm 35x25x13,5 h
~ 7,5 ml
28 impronte - indents



FR075
Micro savarin quadrato

mm 30x30x13,5 h
~ 9,5 ml
28 impronte - indents



FR076
Micro savarin triangolo

mm 30x30x13,5 h
~ 6,5 ml
28 impronte - indents



FR010
Savarin

Ø mm 65x21 h
~ 49 ml
8 impronte - indents



FR015
Savarin

Ø mm 72x23 h
~ 67 ml
6 impronte - indents



FR049
Savarin ovale

mm 80x60x25 h
~ 74 ml
6 impronte - indents

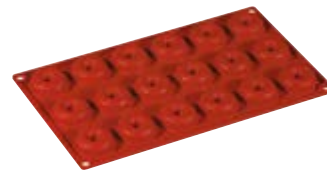

FR005
Mini savarin

Ø mm 41x12 h
~ 12 ml
18 impronte - indents

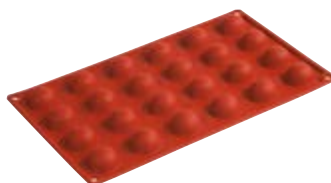

FR004
Semisfera

Ø mm 30x17 h
~ 8,5 ml
24 impronte - indents



FR003
Semisfera

Ø mm 40x20 h
~ 17 ml
15 impronte - indents



FR039
Semisfera

Ø mm 50x23 h
~ 33 ml
15 impronte - indents



FR038
Semisfera

Ø mm 60x30 h
~ 57 ml
8 impronte - indents



FR001
Semisfera

Ø mm 70x35 h
~ 89 ml
6 impronte - indents



FR018
Semisfera

Ø mm 80x40 h
~ 134 ml
5 impronte - indents



FR020
Mini muffin

Ø mm 50x28 h
~ 43 ml
11 impronte - indents



FR008
Muffin

Ø mm 70x40 h
~ 130 ml
6 impronte - indents



FR029
Muffin

Ø mm 80x35 h
~ 110 ml
5 impronte - indents



FR011
Mini tartelletta

Ø mm 45x10 h
~ 12 ml
15 impronte - indents



FR016
Tartelletta

Ø mm 50x15 h
~ 20 ml
15 impronte - indents



FR040
Tartelletta

Ø mm 60x17 h
~ 35 ml
8 impronte - indents



FR077
Charlotte

Ø mm 78x36 h
~ 110 ml
6 impronte - indents



FR078
St. Honorè

Ø mm 80x21 h
~ 55 ml
6 impronte - indents



FR065
Cupcake

Ø mm 50x35 h
~ 100 ml
6 impronte - indents



FR068
Torroncino

mm 50x25x20 h
~ 25 ml
20 impronte - indents



FR026
Madeleine

mm 42x30x11,5 h
~ 8 ml
20 impronte - indents



FR021
Madeleine

mm 68x45x18 h
~ 30 ml
9 impronte - indents

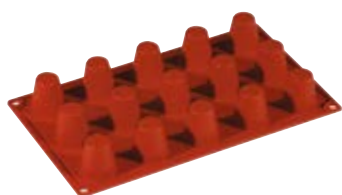

FR031
Babà

Ø mm 35x38 h
~ 25 ml
15 impronte - indents

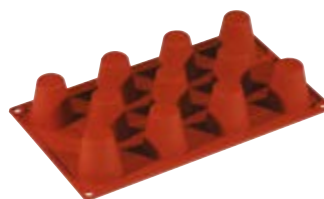

FR030
Babà

Ø mm 45x48 h
~ 51 ml
11 impronte - indents



FR002
Babà

Ø mm 55x60 h
~ 97 ml
8 impronte - indents



FR037
Mini cannelle

Ø mm 35x35 h
~ 24 ml
18 impronte - indents



FR032
Cannelle

Ø mm 56x50 h
~ 70 ml
8 impronte - indents



FR027
Briochette
cannellata

Ø mm 79x30 h
~ 109 ml
6 impronte - indents



FR012
Briochette
cannellata

Ø mm 79x37 h
~ 100 ml
6 impronte - indents



FR024
Petit four

Ø mm 40x20 h
~ 22 ml
15 impronte - indents



FR009
Ovale

mm 53x33x20 h
~ 28 ml
16 impronte - indents



FR041
Ovale

mm 65x41x34 h
~ 52 ml
9 impronte - indents

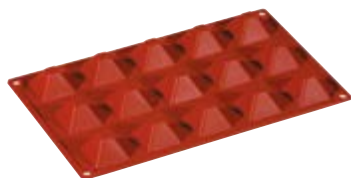

FR013
Mini piramide
 mm 36x36x22 h
 ~ 13 ml
 15 impronte - indents



FR007
Piramide
 mm 71x71x40 h
 ~ 92 ml
 6 impronte - indents



FR017
Cilindro
 Ø mm 60x35 h
 ~ 89 ml
 8 impronte - indents



FR022
Ottagono
 Ø mm 38x26 h
 ~ 28 ml
 15 impronte - indents



FR006
Pomponette
 Ø mm 34x16 h
 ~ 13 ml
 24 impronte - indents



FR035
Bavarese
 Ø mm 57x57 h
 ~ 110 ml
 8 impronte - indents



FR069
Guglhupf
 Ø mm 52x32 h
 ~ 50 ml
 8 impronte - indents



FR046
Guglhupf
 Ø mm 60x33 h
 ~ 70 ml
 6 impronte - indents



FR014
Mini finanziere
 mm 49x26x11 h
 ~ 11 ml
 20 impronte - indents



FR028
Cake
 mm 80x30x30 h
 ~ 62 ml
 9 impronte - indents



FR050
Zucche
 mm 72x61x28 h
 ~ 60 ml
 6 impronte - indents



FR047
Tortine
 Ø mm 80x18 h
 ~ 85 ml
 6 impronte - indents



FR036
Rettangolo
ondine
 mm 80x45x25 h
 ~ 85 ml
 6 impronte - *indents*



FR048
Cabosside
 mm 76x46x23 h
 ~ 30 ml
 6 impronte - *indents*



FR023
Disco per biscuit
 Ø mm 103x20 h
 ~ 160 ml
 3 impronte - *indents*



FR053
Semisfere
accoppiate
 Ø mm 75x43 h
 ~ 128 ml
 6 impronte - *indents*



FR019
Florentine
 Ø mm 60x12 h
 ~ 27 ml
 8 impronte - *indents*



FR045
Margherita
 Ø mm 68x27 h
 ~ 75 ml
 6 impronte - *indents*



FR025
Cuore
 mm 65x60x35 h
 ~ 97 ml
 8 impronte - *indents*



FR064
Cuori
 mm 60x75x67 h
 ~ 110 ml
 8 impronte - *indents*



FR056
Rose
 Ø mm 70x37 h
 ~ 100 ml
 6 impronte - *indents*



FR052
Rose
 Ø mm 75x40 h
 ~ 90 ml
 6 impronte - *indents*



FR070
Ovale tondo
quadrato
 mm 80x70x23 h
 ~ 75 ml
 6 impronte - *indents*



FR071
Tondo quadrato
triangolo
 mm 40x36x12 h
 ~ 8 ml
 18 impronte - *indents*



FR067
Stelle

Ø mm 82x37 h
~ 110 ml
6 impronte - indents



FR096
Swirl

Ø mm 75x38 h
~ 110 ml
6 impronte - indents



FR033
Diamante

Ø mm 35x23 h
~ 13 ml
18 impronte - indents



FR034
Diamante

Ø mm 68x45 h
~ 80 ml
6 impronte - indents



FR103
Cubo

mm 40x40x40 h
~ 62 ml
15 impronte - indents

Formaflex tortiere - Formaflex cake moulds

Formaflex è ideale per sfornare torte e preparazioni dolci e salate. La sua composizione è pensata per la massima anti-aderenza, che garantisce sviluppo e lievitazione dei preparati in modo perfetto, con una resistenza garantita da -40°C a + 250°C.

Formaflex cake moulds are ideal for baking cakes as well as sweet and savoury preparations. The material has been designed for maximum non-stick effect, which ensures perfect rising and baking of your creations, with a guaranteed temperature resistance from -40°C to +250°C.



KE998
Tonda piatta

Ø mm 180x70 h
~ 1760 ml



KE999
Tonda piatta

Ø mm 240x70 h
~ 3130 ml



FRT001
Tonda

Ø mm 200x40 h
~ 1150 ml



FRT002
Tonda

Ø mm 220x40 h
~ 1400 ml



FRT003
Tonda

Ø mm 240x42 h
~ 1850 ml



FRT004
Tonda

Ø mm 260x45 h
~ 2250 ml



FRT005
Tonda

Ø mm 280x45 h
~ 2600 ml



FRT051
Tonda cannellata

Ø mm 260x30 h
~ 1350 ml



FRT052
Tonda cannellata

Ø mm 280x30 h
~ 1600 ml



FRT053
Tonda cannellata

Ø mm 300x30 h
~ 1850 ml



FRT054
Tonda cannellata
con fondo rialzato

Ø mm 260x30 h
~ 1350 ml



FRT056
Tonda cannellata
con fondo rialzato

Ø mm 300x30 h
~ 1770 ml



FRT058
Crostatata

Ø mm 280x30 h
~ 1700 ml



FRT103
Ciambella
dentata

Ø mm 240x60 h
~ 1685 ml



FRT104
Guglhupf

Ø mm 220x110 h
~ 2750 ml



FRT077
 Rettangolare

mm 280x240x40 h
~ 2670 ml



FRT106
Plumcake

mm 240x105x65 h
~ 1385 ml



FRT120
Plumcake

mm 280x105x65 h
~ 1660 ml

Stampi monouso
Disposable moulds





Stampi monouso per la creazione di torte con raggio stondato. I bordi arrotondati permettono una perfetta glassatura evitando il taglio della glassa e la nuova linguetta extra-grip rende l'operazione di smodellaggio facile ed immediata.

- Risparmio di tempo e di spazio.
- Stoccaggio razionalizzato dovuto all'impilabilità del prodotto.
- Linguette extra-grip facili da usare che permettono un perfetto smodellaggio del prodotto finale.
- Stop alla condensa e al ritiro del prodotto in abbattitore.
- Massime igiene e facilità d'uso.

Disposable moulds to create rounded rim cakes. The curved edges will help you to obtain the perfect glazing avoiding the usual unsightly defect on the rim.

- *Space and time-saving.*
- *Rational storing because the product is easy to stack.*
- *Extra-grip tear strip easy to use material to perfectly demould the final product.*
- *No more condensation and no more shrinking of the product in the blast chiller.*
- *Maximum hygiene and easy to use.*



Voilà per torte Voilà for cakes

VL240

NEW

Ø mm 240x40 h

100 pcs per confezione
100 pcs per box

VL220

Ø mm 220x40 h

100 pcs per confezione
100 pcs per box

VL200

Ø mm 200x40 h

150 pcs per confezione
150 pcs per box

VL180

Ø mm 180x40 h

225 pcs per confezione
225 pcs per box

VL160

Ø mm 160x40 h

300 pcs per confezione
300 pcs per box

VL140

Ø mm 140x40 h

300 pcs per confezione
300 pcs per box

Voilà per monoporzioni Voilà for single-serving portions

VL65

NEW

Ø mm 65x40 h

900 pcs per confezione
900 pcs per box

How to use



Voilà per quadri Voilà frames

VL6430

NEW

Dim. internal
mm 570x365x30 h

Dim. external
mm 590x390x30 h

30 pcs per confezione
30 pcs per box

VL6435

NEW

Dim. internal
mm 570x365x35 h

Dim. external
mm 590x390x35 h

30 pcs per confezione
30 pcs per box

VL6440

NEW

Dim. internal
mm 570x365x40 h

Dim. external
mm 590x390x40 h

30 pcs per confezione
30 pcs per box

VL4030

NEW

Dim. internal
mm 360x360x30 h

Dim. external
mm 390x390x30 h

50 pcs per confezione
50 pcs per box

VL4035

NEW

Dim. internal
mm 360x360x35 h

Dim. external
mm 390x390x35 h

50 pcs per confezione
50 pcs per box

How to use



**GEL
ATO**

Rainbow Stick



**NEW**

Un arcobaleno di gusti. Rainbow Stick reinventa lo stecco gelato con un kit che ti permetterà di dare sfogo alla tua fantasia, strato su strato. Si compone di uno stampo Pavoflex per la creazione di anelli di gelato da guarnire a piacimento, stecchi gelato e dei comodi fermastecco, che mantengono gli anelli in posizione. Tutto quello che ti occorre per reinterpretare il gelato in modo moderno, facile e creativo.

A rainbow of flavours. Rainbow Stick reinvents the ice cream on a stick with a kit that will allow you to unleash your imagination, layer upon layer. It consists of a Pavoflex mould for creating ice cream rings to be garnished at will, sticks and handy stick fasteners to keep the rings in place. Everything you need to reinterpret ice cream in a modern, easy and creative way.

Silvia Federica Boldetti x Rainbow Stick

Una regina della creatività in pasticceria. Silvia Federica Boldetti è The Pastry Queen 2016: una campionessa del Mondo capace di colpire con il talento e il sorriso. Insieme al team Pavoni Italia ha sviluppato Rainbow Stick, il kit per gelati a stecco che pare fatto per essere fotografato... e gustato! Una soluzione semplice per ravvivare la tua vetrina in gelateria.

A creativity queen in pastry. Silvia Federica Boldetti is the 2016 Pastry Queen: a World Champion able to strike with her talent and her smile. Together with the Pavoni Italia team, she has developed Rainbow Stick, the kit for ice cream on a stick that you can't help taking a picture at... and enjoy! A simple solution to liven up the window of your ice cream shop.



NEW

PX3212S

Rainbow stick

mm 46x35x12 h
~ 12 ml

20 impronte - indents

Kit stampo in silicone 300x175 mm
+50 stecchi+50 fermastecchi

Kit silicone moulds 300x175 mm
+50 sticks+50 stick fasteners

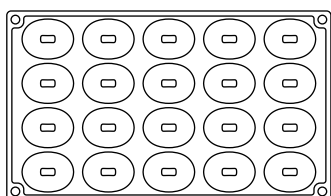





Gelato decoration



Top Ice

Top Ice è la linea di stampi in silicone per la decorazione delle vaschette gelato. Il modo nuovo, semplice e rapido di creare una vetrina capace di catturare lo sguardo. Cinque trame diverse, tutte da interpretare in modo personale, per dare a ogni gelato l'aspetto che si merita.

Top Ice is the line of silicone moulds for decorating ice cream pans. The new, simple and quick way to create a window able to catch the eye. Five different textures, all to be interpreted and decorated in a personal way, to give each ice cream the look it deserves.

Vaschetta intera Whole pan

Vaschetta piccola Half pan



TOP100 Iceberg

mm 361,5x251,5x21 h
~ 740 ml



TOP106 Iceberg

mm 361,5x152x20 h
~ 440 ml

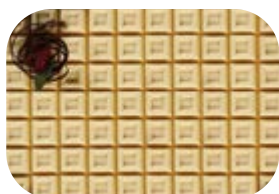

TOP101 Tablet

mm 361,5x251,5x18,5 h
~ 985 ml



TOP107 Tablet

mm 361,5x152x18,5 h
~ 615 ml



TOP102 Coral

mm 361,5x251,5x21,5 h
~ 1090 ml



TOP105 Coral

mm 361,5x152x21,5 h
~ 651 ml



TOP103 Sofa

mm 361,5x251,5x21 h
~ 929 ml



TOP104 Dune

mm 361,5x251,5x21 h
~ 840 ml

A top-down view of several gelato sticks on a grey, textured background. The sticks are arranged in a scattered pattern. Some are plain white, some are plain dark chocolate, and some are coated in dark chocolate with a ribbed texture. The sticks are on light-colored wooden sticks. A red border is visible around the central part of the image.

Gelato stick



Pavogel

Una linea di stampi per gelati a stecco dalle forme e dettagli sorprendenti. Tante soluzioni per stupire la clientela con trame e design originali che saranno protagonisti da subito in vetrina. Pavogel è disponibile anche nei formati Pocket e Snack, dalle dimensioni ridotte, per ampliare la tua possibilità d'offerta.

- Pavogel
- Pavogel Pocket
- Pavogel Snack

A line of moulds for ice cream on a stick, with amazing shapes and details. Many options to amaze your customers with original textures and designs that will immediately be the main stars of your shop window. Pavogel is also available in Pocket and Snack versions, in small sizes, to increase your range of products.

- Pavogel
- Pavogel Pocket
- Pavogel Snack

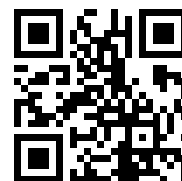

Guarda il video dedicato a **Pavogel** sul canale Youtube di Pavoni Italia

Watch the video **Pavogel** on Pavoni Italia's Youtube channel

Pavogel

Dimensione stampo singolo - *Single mould size 200x150 mm*
 Dimensione kit 4 stampi - *Kit 4 moulds size 400x300 mm*

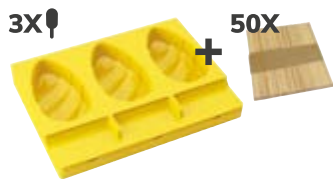

Single mould

PL01 Malibù

mm 52x95 h
 ~ 85 ml
 Stampo singolo+50 stecchi
Single mould+50 sticks
 3 impronte - 3 indents

Kit 4 moulds

KITPL01 Malibù

Kit 4 stampi+vassoio+50 stecchi
Kit 4 moulds+tray+50 sticks
 12 impronte - 12 indents
 16 kit per masterbox
 16 kit for masterbox

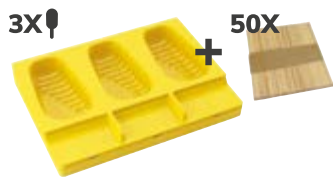

Single mould

PL02 Acapulco

mm 50x95 h
 ~ 90 ml
 Stampo singolo+50 stecchi
Single mould+50 sticks
 3 impronte - 3 indents

Kit 4 moulds

KITPL02 Acapulco

Kit 4 stampi+vassoio+50 stecchi
Kit 4 moulds+tray+50 sticks
 12 impronte - 12 indents
 16 kit per masterbox
 16 kit for masterbox

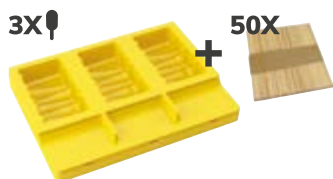

Single mould

PL03 Maracaibo

mm 48x85 h
 ~ 85 ml
 Stampo singolo+50 stecchi
Single mould+50 sticks
 3 impronte - 3 indents

Kit 4 moulds

KITPL03 Maracaibo

Kit 4 stampi+vassoio+50 stecchi
Kit 4 moulds+tray+50 sticks
 12 impronte - 12 indents
 16 kit per masterbox
 16 kit for masterbox

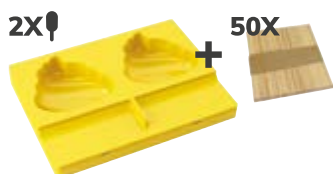

Single mould

PL04 Honolulu

mm 83x84 h
 ~ 100 ml
 Stampo singolo+50 stecchi
Single mould+50 sticks
 2 impronte - 2 indents

Kit 4 moulds

KITPL04 Honolulu

Kit 4 stampi+vassoio+50 stecchi
Kit 4 moulds+tray+50 sticks
 8 impronte - 8 indents
 16 kit per masterbox
 16 kit for masterbox

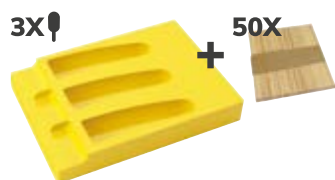

Single mould

PL05

Ipanema

mm 35x110 h
~ 70 ml

Stampo singolo+50 stecchi
Single mould+50 sticks
3 impronte - 3 indents

Kit 4 moulds

KITPL05

Ipanema

Kit 4 stampli+vassoio+50 stecchi
Kit 4 moulds+tray+50 sticks

12 impronte - 12 indents
16 kit per masterbox
16 kit for masterbox

Pavogel Pocket

Dimensione stampo singolo - Single mould size 200x120 mm

Dimensione kit 2 stampli - Kit 2 moulds size 400x120 mm



Single mould

PL06

Malibù

mm 40x72 h
~ 35 ml

Stampo singolo+50 stecchi
Single mould+50 sticks
4 impronte - 4 indents

Kit 4 moulds

KITPL06

Malibù

Kit 2 stampli+vassoio+50 stecchi
Kit 2 moulds+tray+50 sticks

8 impronte - 8 indents
12 kit per masterbox
12 kit for masterbox



Single mould

PL07

Maracaibo

mm 37x65 h
~ 35 ml

Stampo singolo+50 stecchi
Single mould+50 sticks
4 impronte - 4 indents

Kit 4 moulds

KITPL07

Maracaibo

Kit 2 stampli+vassoio+50 stecchi
Kit 2 moulds+tray+50 sticks

8 impronte - 8 indents
12 kit per masterbox
12 kit for masterbox



Single mould

PL08

Waikiki

mm 40x70 h
~ 35 ml

Stampo singolo+50 stecchi
Single mould+50 sticks
4 impronte - 4 indents

Kit 4 moulds

KITPL08

Waikiki

Kit 2 stampli+vassoio+50 stecchi
Kit 2 moulds+tray+50 sticks

8 impronte - 8 indents
12 kit per masterbox
12 kit for masterbox



Single mould

PL09
Cupcake

mm 50x70 h
~ 40 ml
Stampo singolo+50 stecchi
Single mould+50 sticks
3 impronte - 3 indents

Kit 4 moulds

KITPL09
Cupcake

Kit 2 stampli+vassoio+50 stecchi
Kit 2 moulds+tray+50 sticks
6 impronte - 6 indents
12 kit per masterbox
12 kit for masterbox

Pavogel Snack

Dimensione stampo singolo - Single mould size 200x120 mm
Dimensione kit 2 stampli - Kit 2 moulds size 400x120 mm



Single mould

PL10
Linear

mm 20x60 h
~ 25 ml
Stampo singolo+50 stecchi
Single mould+50 sticks
5 impronte - 5 indents

Kit 4 moulds

KITPL10
Linear

Kit 2 stampli+vassoio+50 stecchi
Kit 2 moulds+tray+50 sticks
10 impronte - 10 indents
12 kit per masterbox
12 kit for masterbox

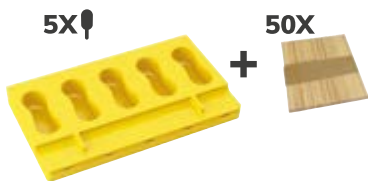

Single mould

PL11
Bubbles

mm 25x60 h
~ 20 ml
Stampo singolo+50 stecchi
Single mould+50 sticks
5 impronte - 5 indents

Kit 4 moulds

KITPL11
Bubbles

Kit 2 stampli+vassoio+50 stecchi
Kit 2 moulds+tray+50 sticks
10 impronte - 10 indents
12 kit per masterbox
12 kit for masterbox

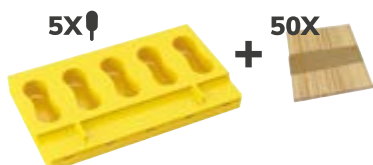

Single mould

PL12
Round

mm 23x60 h
~ 20 ml
Stampo singolo+50 stecchi
Single mould+50 sticks
5 impronte - 5 indents

Kit 4 moulds

KITPL12
Round

Kit 2 stampli+vassoio+50 stecchi
Kit 2 moulds+tray+50 sticks
10 impronte - 10 indents
12 kit per masterbox
12 kit for masterbox

Accessori per Pavogel e Rainbow Stick Accessories for Pavogel and Rainbow Stick

Stecchi - Sticks



KS47

per - for Pavogel, Rainbow Stick
Confezione da 50 stecchi
Pack of 50 sticks



KS48

per - for Pavogel Pocket,
Pavogel Snack
Confezione da 50 mini stecchi
Pack of 50 mini sticks

Fermastecchi - Stick fasteners



KSSUP

per - for Rainbow Stick
Confezione da 50 fermastecchi
Pack of 50 stick fasteners

Vassoi - Trays



TRAYGEL

per - for Pavogel
mm 400x300x10 h



TRAYGELMINI

per - for Pavogel
mm 400x120x10 h

Espositore - Display



PAVOGEL

Espositore in policarbonato per gelati su stecco
Polycarbonate display for ice cream on a stick

per - for Pavogel, Pavogel Pocket, Pavogel Snack, lollipops
mm 360x235

44 fori - holes

**CO
LOU
RS
&
RAW
MATE
RIALS**

Magic Decor



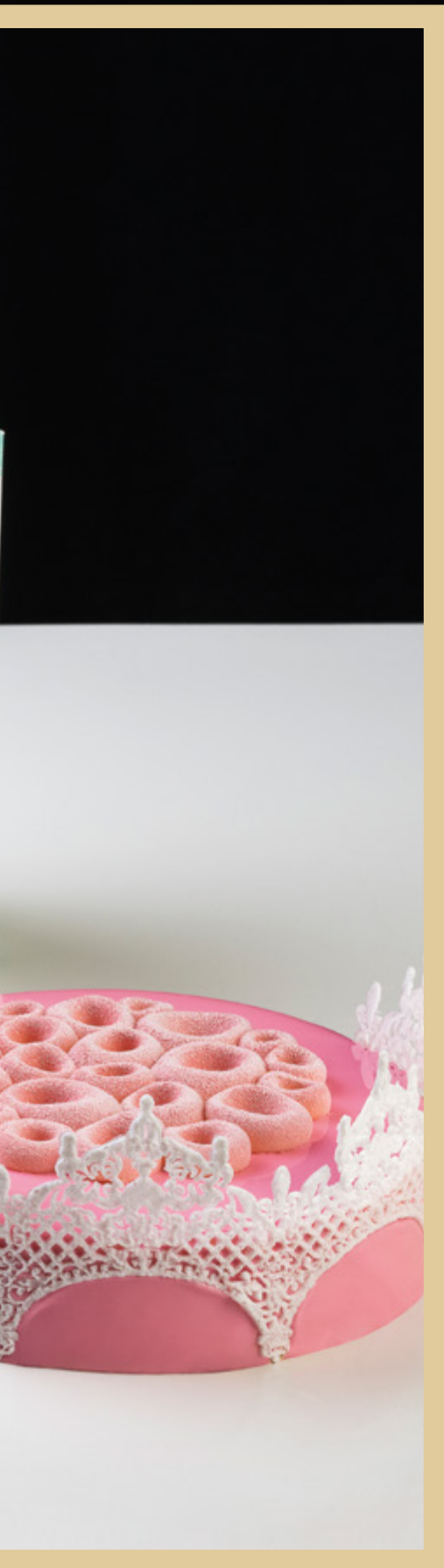

Magic Decor è l'innovativo preparato in polvere che, in abbinamento ai tappetini Magic Decor in silicone, permette di realizzare pizzi in zucchero estremamente elastici e sottili per abbellire le tue creazioni.

Decora torte e preparazioni attraverso un vero effetto tridimensionale, che saprà catturare l'attenzione dei clienti, per un successo garantito nelle occasioni più speciali.

Magic Decor is an innovative powder preparation you can use on our Magic Decor silicone mats. You can create amazing sugar laces you can use to embellish your creations.

Decorate cakes and other creations with a real three-dimensional effect, which will catch your customers' eyes, for a guaranteed success in the most special events.



MAGICDECOR250

250 g

MAGICDECOR

500 g

MAGICDECOR3

3000 g

Strisce in silicone Stripe silicone mats



SMD03

mm 390x80,5 h



SMD04A

mm 390x80,5 h



SMD04B

mm 390x80,5 h



SMD05

mm 390x80,5 h



SMD07A

mm 390x80,5 h



SMD07B

mm 390x80,5 h



SMD08

mm 390x80,5 h



SMD09

mm 390x80,5 h



SMD10

mm 390x80,5 h



SMD11

mm 390x80,5 h



SMD12

mm 390x80,5 h



SMD102

mm 368x135 h



TMD01

mm 400x300 h



TMD02

mm 400x300 h

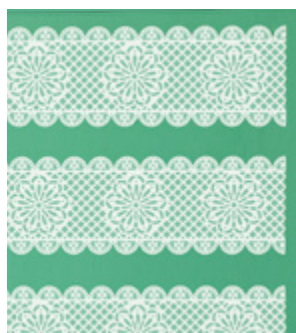

TMD03

mm 400x300 h



TMD04

mm 400x300 h



TMD05

mm 400x300 h



TMD06

mm 400x300 h



TMD07

mm 400x300 h



TMD08

mm 400x300 h



TSD11

mm 600x400 h



TSD12

mm 600x400 h

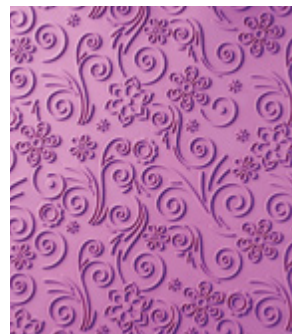

TSD13

mm 600x400 h



TSD14

mm 600x400 h

TSD14-2

mm 400x300 h

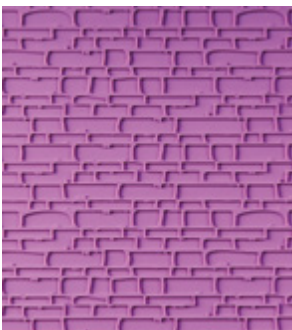

TSD15

mm 600x400 h

TSD15-2

mm 400x300 h



TSD16

mm 600x400 h

TSD16-2

mm 400x300 h



TSD17

mm 600x400 h

TSD17-2

mm 400x300 h



TB05

mm 600x400 h

Tappeti a rilievo
Relief mats

Zucchero artistico
Artistic sugar

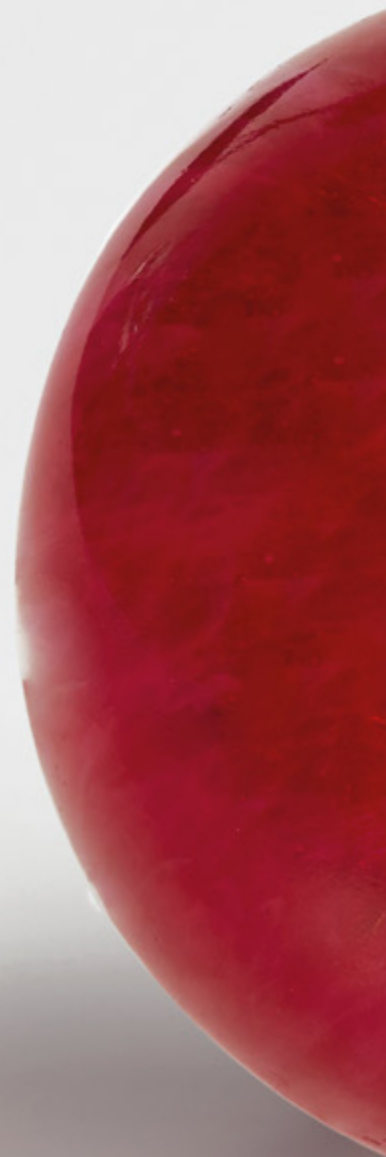



Sfere in silicone disponibili in tre diverse misure per la realizzazione di soggetti in zucchero artistico. Il particolare design a tutto tondo permette un raffreddamento rapido del prodotto finito. L'incavo centrale garantisce un facile smodellaggio del prodotto.

Silicone sphere moulds available in three different sizes, designed to create artistic sugar show pieces. The specific three dimensional design allows a much faster cooling of the sugar. The cavity guarantees the easy demoulding of the product.



Sfere

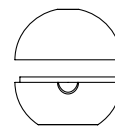

SFERA80

Ø mm 80
~ 270 ml

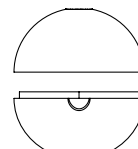

SFERA100

Ø mm 100
~ 525 ml

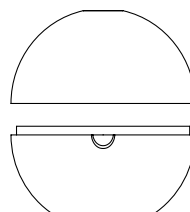

SFERA150

Ø mm 150
~ 1770 ml

Isomalto



CODE	PESO WEIGHT (g)
ISOPAV500	500
ISOMALTOKG1	1000
ISOMALTOKG5	5000

Attrezzature - Equipment

Cannello a gas - Blow torch

Cannello dalla fiamma mediamente sottile, robusto e ideale per la lavorazione dello zucchero artistico e caramellature.

Torch with thin flame, robust and ideal for the processing of the artistic sugar and caramelization.



CODE

FLAME

Aladin

Lampada a infrarossi a tre potenze selezionabili: 500, 1000 e 1500 W. Struttura e piano di lavoro in acciaio inox. Completamente smontabile. Cavo di alimentazione incluso.

Infrared lamp with three switchable powers: 500-1000-1500 W. Stainless steel structure and working plan. Fully demontable. Power cable included.

CODE	PIANO DI LAVORO WORKING PLAN (mm)	INGOMBRO SIZE (mm)	PESO WEIGHT (kg)
ALADIN	610x410	610x410x500 h	6,4



Lampada per zucchero

Interamente in acciaio inox, completa di cassetto porta attrezzi, variatore di potenza e due resistenze porcellanane.

Completely stainless steel made, provided with drawer for tools, power variator and two porcelained resistances.

CODE	POTENZA POWER (W)	TENSIONE D'ESERCIZIO VOLTAGE (V)	PIANO DI LAVORO WORKING PLAN (mm)	PESO WEIGHT (kg)
1 LAMPADA	800	230	600x400	5

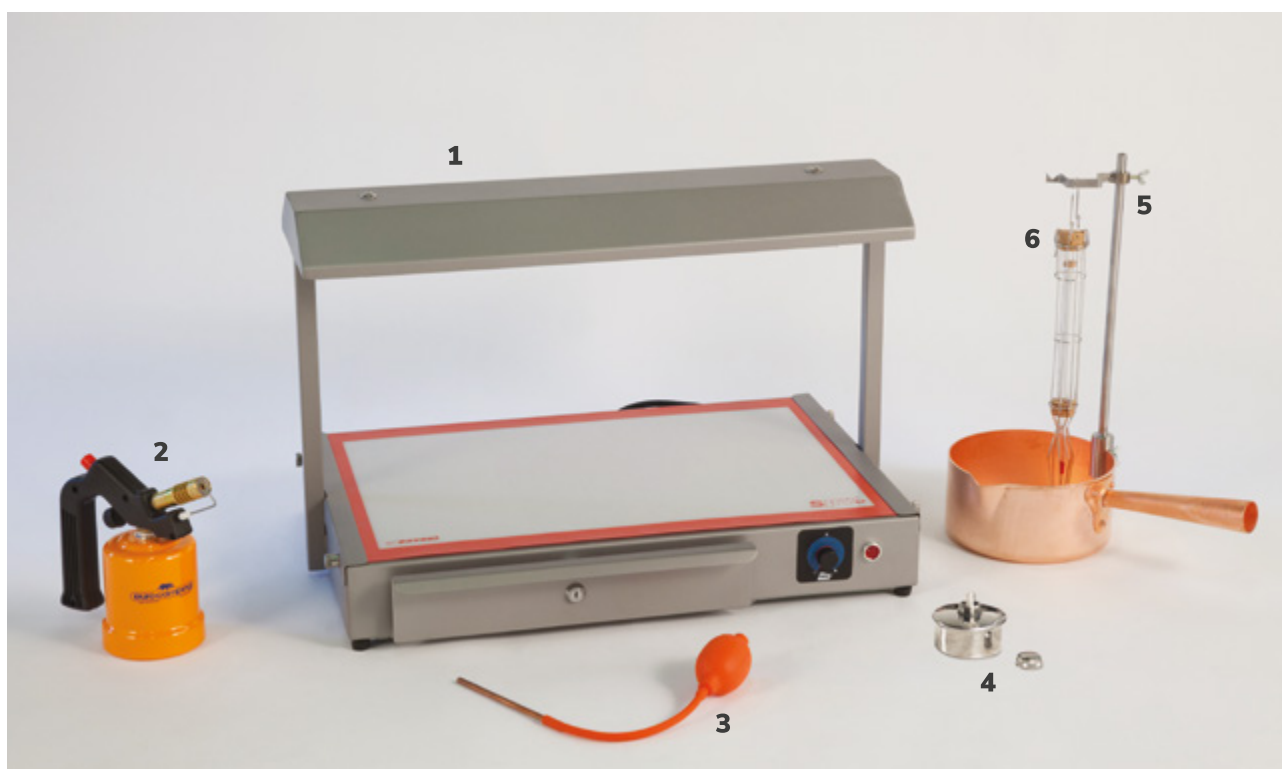

CODE	DESCRIPTION
2 CANNELLO	con accensione automatica torch with automatic ignition
3 POMPETTA	con terminale in rame pump with copper terminal
4 BAZ	bocchetta alcool con stoppino stainless steel bottle with alcool wick

CODE	DESCRIPTION
5 RG1	reggi caramellometro holder for sugar thermometer
6 CARAMELLOMETRO	con gabbia sugar thermometer with housing

**Colori e
materie prime**
*Colours &
raw materials*



STAR DUST

POLVERE
EXTRAFINE
PERLESCENTE
EXTRA-FINE
COLORED
POWDER
ORO / GOLD
COD. 502
10 g



POLVERE EXTRA-FINE
PER DECORAZIONE MEDICINALE
Ingredienti: E555, E173, E571
Può contenere tracce di latte,
guscio e latte.
Non ingerire! Adatto per
uso su prodotti da forno.
Non ingerire! Adatto per
uso su prodotti da forno.
Non ingerire! Adatto per
uso su prodotti da forno.
Non ingerire! Adatto per
uso su prodotti da forno.

Prodotto nella stabilimento
via Liguria, 8 - 42024 Lodi
Pavoni Italia S.p.A. - Tel. 0423 400000
www.pavonitalia.com

Palette di concentrati naturali

Natural extract palette

NEW

Seasons è la palette a base di concentrati naturali, tra i quali cartamo, zucca, succo di barbabietola e molti altri, sviluppata in collaborazione con il Campione del Mondo di Pasticceria Emmanuele Forcone. Una gamma di "colori non colori", vegan friendly, sostenibile e amica della natura, dall'estrema versatilità, ampia gamma cromatica, dal gusto moderno, contemporaneo e naturale. Una novità disponibile sia a base burro di cacao sia in polvere. Una gamma nuova, una tavolozza unica e ricca di sfumature.

A palette based on natural concentrates, among which safflower, pumpkin, beetroot juice and many others developed in cooperation with the World Pastry Champion Emmanuele Forcone. A range of "colours non colours" which are vegan friendly, sustainable and eco-friendly, with extreme versatility, wide colour range, flavourless but with a modern and contemporary approach. An innovation available both as cocoa butter and as powder. A new range, a unique and rich palette of nuances.



Concentrati naturali a base burro di cacao

Cocoa butter natural concentrates

La palette di concentrati vegetali Seasons è disponibile a base burro di cacao per la colorazione di masse di cioccolato, per l'applicazione diretta a spruzzo o pennello su stampi, acetati e fogli chitarra, oppure all'interno di glasse o finiture ad effetto velluto. Un arcobaleno naturale vegan friendly capace di dare carattere e colore a praline, tavolette, torte, petit four e tanto altro ancora.

Seasons, the vegetable concentrate palette, is available as cocoa butter based range for colouring chocolate masses, to be sprayed or brushed on moulds, acetates and guitar sheets, for colouring your glazes or even for velvet effect finishing. A whole natural rainbow, totally vegan friendly, capable of giving character and colour to your pralines, choco bars, cakes, petit fours and much more.



CODE	COLOUR	
NC01*	verde mela apple green	
NC02*	verde green	
NC03*	azzurro light blue	
NC04*	giallo yellow	
NC05*	rosso ciliegia cherry red	
NC06*	arancione orange	

CODE	COLOUR	
NC07*	viola purple	
NC08*	marrone fondente dark brown	
NC09*	rosa pink	
NC10*	rosso red	
NC11*	marrone latte milk cocoa	

*Colori AZO free - AZO free colours.



Concentrati naturali in polvere

Powdered natural concentrates

Seasons aggiunge un tocco in più alle tue preparazioni. Glasse, impasti, creme, farciture, frolle, viennoiserie: sono solo alcuni degli usi possibili di Seasons. Concentrati vegetali a base di alga spirulina, zucca, barbabietola e molti altri: una palette tutta naturale che darà un look personale alle preparazioni, con tante variazioni cromatiche.

Seasons adds an extra touch to your preparations. Icing, doughs, creams, fillings, shortcrust pastry, viennoiserie: these are just some of Seasons many uses. Plant extracts based of spirulina algae, pumpkin, beetroot and many others: a whole natural palette which will give a personal touch to your preparations, with many colour variations.



CODE	COLOUR	
NCP01*	verde mela apple green	
NCP02*	verde green	
NCP03*	azzurro light blue	
NCP04*	giallo yellow	
NCP05*	rosso ciliegia cherry red	

CODE	COLOUR	
NCP06*	arancione orange	
NCP07*	viola purple	
NCP08*	marrone fondente dark brown	
NCP09*	rosa pink	
NCP10*	rosso red	

*Colori AZO free - AZO free colours.



Le qualità di Seasons

Seasons' plus

- 100% prodotto naturale;
 - vegan friendly;
 - OGM free;
 - AZO free;
 - concentrati naturali selezionati accuratamente.
-
- 100% natural product;
 - vegan friendly;
 - GMO free;
 - AZO free;
 - carefully selected natural concentrates.



Colori in spray - Spray colours

Dolce Velluto 400 ml - Velvet spray 400 ml

Look morbido e prezioso. Dolce Velluto è lo spray a base di burro di cacao colorato. Spruzzando su superfici fredde il burro di cacao cristallizza, creando lo speciale effetto velluto.

For a soft and precious look. Dolce Velluto is a spray made with coloured cocoa butter. By spraying onto cold surfaces, the cocoa butter crystallises, creating the special velvet effect.



CODE	COLOUR	
DV1	rosso red	
DV2	arancione orange	
DV3	giallo yellow	
DV4	rosa pink	
DV5*	marrone scuro dark brown	
DV6	marrone chiaro light brown	
DV7*	bianco white	

CODE	COLOUR	
DV8	pistachio pistachio	
DV9*	azzurro light blue	
DV12	rosso ciliegia red cherry	
DV14	nero black	
DV15	blu tiffany blue tiffany	
DV16*	argento silver	
DV17	oro argento	

*Colori AZO free - AZO free colours.



Spray metallizzati 150 ml - Metallized spray 150 ml

A base alcolica, da utilizzare per decorare dolci e torte, cioccolato, pasta di zucchero e molto altro.

Alcohol based, suitable to decorate sweets and cakes, chocolate, sugar paste and more.



CODE	COLOUR	
SM01*	oro gold	
SM02*	argento silver	
SM03*	rubino ruby	
SM04*	bronzo bronze	
SM05*	cobalto cobalt	

CODE	COLOUR	
SM06	verde green	
SM07	oro chiaro light gold	
SM08	blu tiffany blue tiffany	
SM09	argento scuro dark silver	

*Colori AZO free - AZO free colours.





Spray pastello 250 ml - Pastel spray 250 ml

A base acquosa, pronti all'uso per decorare e colorare torte a base di panna e cioccolato, prodotti di pasticceria come biscotti, wafer, cialde e dolci a base di pasta di zucchero.

Water based, ready to use, ideal to decorate creams and chocolate cakes, pastry products like biscuits, wafers and sugar paste covered cakes.



CODE	COLOUR	
SP01250	rosso red	
SP02250	rosa pink	
SP03250	marrone brown	
SP04250	giallo yellow	

CODE	COLOUR	
SP05250*	blu blue	
SP06250*	cobalto cobalt	
SP07250	arancione orange	
SP08250	verde green	

*Colori AZO free - AZO free colours.



Colori in polvere - Powder colours

Idrosolubili in polvere 50 g - Water soluble powder 50 g

Linea di colori Absolute ad altissima intensità studiata per le lavorazioni in zucchero artistico, sviluppata in collaborazione con Emmanuele Forcone. Basta una piccola quantità di polvere per ottenere colori pieni. Ideali anche per preparazioni di macaron, pasta di zucchero e ghiaccia.

The high intensity Absolute colour line designed with Emmanuele Forcone for the processing of the artistic sugar. Just a small amount of powder let you achieve full colour. Also ideal for macaron preparations, sugar paste and icing.



CODE	COLOUR	
A01	rosso ciliegia red cherry	
A02	arancione orange	
A03	giallo yellow	
A04	verde mela green apple	
A05	verde green	
A06*	blu blue	

CODE	COLOUR	
A07	viola purple	
A08	rosa pink	
A09	marrone brown	
A10	nero black	
A11	rosso vivo bright red	

*Colori AZO free - AZO free colours.



Metallizzati in polvere 40 g - Metallized powder 40 g

Linea di colori Brilliant, ideata con Emmanuele Forcone, per donare un effetto perlescente e brillante alle tue lavorazioni in cioccolato, zucchero o pastigliaggio. Solubili in alcool o impiegabili allo stato puro.

Brilliant colour line, developed with Emmanuele Forcone, to give a pearlescent and brilliant effect to your chocolate, sugar or pastillage creations. Can be dissolved in alcohol or used as is.



CODE	COLOUR	
M01*	oro gold	
M02*	argento silver	
M03*	rubino ruby	
M04*	bronzo bronze	

CODE	COLOUR	
M05*	cobalto cobalt	
M06*	verde green	
M07*	rame copper	

*Colori AZO free - AZO free colours.



Liposolubili in polvere 40 g - Fat soluble powder 40 g

Linea di colorazioni Chocolart originali, realizzata in collaborazione con Emmanuele Forcone. Lacche in polvere ad altissima intensità da sciogliere nel burro di cacao.

Chocolart colour line, developed in collaboration with Emmanuele Forcone. High intensity lacquers powder to be dissolved in the cocoa butter.



CODE	COLOUR	
L01*	verde mela green apple	
L02*	verde green	
L03*	blu blue	
L04*	giallo brillante bright yellow	
L05	giallo yellow	
L06	arancione orange	
L07*	nero black	

CODE	COLOUR	
L08*	bianco white	
L09	rosa pink	
L10	rosso red	
L11*	lilla lilac	
L12*	NEW blu tiffany blue tiffany	

*Colori AZO free - AZO free colours.



Polvere perlescente 10 g - Pump powder 10 g

Una cascata di brillantezza! Stardust è una fine polvere perlescente con pompetta ad aria ideale per decorare prodotti finiti a base di cioccolato, torte o semifreddi.

A waterfall of sparkles! Stardust is a thin pearlescent powder with air pump, ideal for decorating finished products such as chocolate, cakes or semifreddo.



CODE	COLOUR	
S01*	rubino ruby	■
S02*	oro gold	■
S03*	argento silver	■

*Colori AZO free - AZO free colours.



Colori al burro di cacao - Cocoa butter colours

Colori al burro di cacao 200 g - Cocoa butter colours 200 g

Colori Chocolart pronti all'uso con un perfetto dosaggio di colore, sviluppati in collaborazione con Emmanuele Forcone. Ideali per colorare cioccolato nella massa, in superficie e in stampo.

Chocolart colours ready to use with a perfect colour dosage. Ideal for colouring chocolate in the mass, surface and mould.



CODE	COLOUR	
LB01*	verde mela green apple	■
LB02*	verde green	■
LB03*	blu blue	■
LB04*	giallo brillante bright yellow	■
LB05	giallo yellow	■
LB06	arancione orange	■
LB07*	nero black	■

CODE	COLOUR	
LB08*	bianco white	■
LB09	rosa pink	■
LB10	rosso red	■
LB11*	lilla lilac	■
LB12*	oro gold	■
LB13*	argento silver	■

*Colori AZO free - AZO free colours.



Colori liquidi - Liquid colours

Liposolubili 180 g - Fat soluble 180 g

Ideali per la colorazione di masse di cioccolato e di tutte le masse grasse.

Suitable to colour mass of chocolate and all fat masses.



CODE	COLOUR	
LL01	verde green	
LL02	giallo yellow	
LL03*	bianco white	
LL07	rosso red	

CODE	COLOUR	
LL08*	blu blue	
LL10*	nero black	
LL11	giallo brillante bright yellow	

*Colori AZO free - AZO free colours.





Idrosolubili 250 ml - Water soluble 250 ml

Colori idrosolubili a base di acqua per aerografo.

Water soluble colours for airbrush.



CODE	COLOUR	
CLA	11 colori 11 colours	
CL01	verde brillante bright green	
CL02	giallo yellow	
CL03	bianco white	
CL04	viola purple	
CL05	marrone brown	

CODE	COLOUR	
CL06	azzurro light blue	
CL07	rosso red	
CL08	blu blue	
CL09	rosa pink	
CL10	nero black	
CL11	giallo brillante bright yellow	



Decorazioni - Decorations

Granelle perlescenti in cioccolato fondente 120 g Dark chocolate grains in bright colours 120 g

Decorazioni in cioccolato per regalare un twist luminoso ed elegante alle tue preparazioni.

Chocolate decorations to give a bright and elegant twist to your creations.



CODE	COLOUR	
GP01	rame copper	
GP02	rubino ruby	
GP03	oro gold	



CODE	COLOUR	
GP04	argento silver	
GP05	verde green	

Scaglie - Flakes

Perfette per impreziosire e decorare le tue creazioni, dalle torte al cioccolato, con dettagli lussuosi e raffinati.

Perfect for embellishing and decorating your creations, from cakes to chocolate, with luxurious and refined details.





CODE	COLOUR		PESO WEIGHT (g)
ARGENTO SC	argento silver		2
ORO SC	oro gold		2

Fogli - Sheets

Fogli di oro e argento ideali per la decorazione, il topping e le rifiniture delle preparazioni.

Edible gold and silver sheets, ideal for the decoration, topping and finishing of your creations.



CODE	COLOUR		DIMENSION (mm)	FOGLI SHEETS
ARGENTO	argento silver		95x95	25
ORO	oro gold		80x80	25

Chocoice 400 ml



Refrigerante spray per zucchero e cioccolato.

Chocolate and sugar spray cooler.

CODE

CHOCOICE*

*Colori AZO free - AZO free colours.



Brillspray 400 ml



Lucidante spray per cioccolato, zucchero e marzapane.

Chocolate, sugar and marzipan spray glazing.

CODE

BRILLSPRAY

Decotab 6 kg



Decotab è una pasta estremamente malleabile, ideale per la copertura delle torte, da stendere a mano o con sfogliatrice, fino a spessori di 1 mm. Il burro di cacao contenuto in Decotab lo rende utile anche per la realizzazione di soggetti e decorazioni come fiori e foglie. Decotab è bianco, con un leggero aroma di mandorla, e può essere facilmente colorato utilizzando i colori idrosolubili Pavoni Italia.

Decotab is a very malleable paste. Roll it out with a rolling pin or a sheeter up to 1 mm thick and it can be used to cover cakes. The cocoa butter content of Decotab makes this product an ideal paste for the realization of subjects and decorations like flowers and leaves. Decotab is white coloured with an almond hint and it can be also easily coloured by using the water soluble Pavoni Italia food colours.

CODE

COLOUR

DECOTAB

bianco
white



Decotab colours 1 kg

Realizzate con la stessa ricetta di Decotab, le paste di zucchero Decotab colours offrono molteplici possibilità decorative con un notevole risparmio di tempo e grande omogeneità di colore.

Made with the same recipe for Decotab, the Decotab coloured sugar pastes offer many decorative opportunities with remarkable time-saving and a perfect colour homogeneity.



CODE	COLOUR	CODE	COLOUR
DECOTABRC	color carne light rose	DECOTABCO	marrone brown
DECOTABBN	bianco white	DECOTABVC	verde chiaro light green
DECOTABRA	rosa pink	DECOTABFU	fucsia fuchsia
DECOTABAR*	arancione orange	DECOTABAZ	azzurro light blue
DECOTABN	nero black	DECOTABG	giallo brillante bright yellow
DECOTABR	rosso red	DECOTABVS	verde green
DECOTABBL	blu blue		

Ciocoplast 6 kg



Il cioccolato plastico per modellaggio Ciocoplast è l'ideale per la creazione di soggetti, fiori e nastri. L'estrema malleabilità di questo prodotto lo rende adatto anche alla copertura di torte. Non si attacca alle mani, rimane morbido per giorni e ha un gradevole sapore di cioccolato. Disponibile nei colori bianco e marrone.

The plastic chocolate is the ideal product for the creation of flowers and ribbons, thanks to its consistency. The extreme malleability and plasticity of this product make it suitable to cover cakes too. Ciocoplast does not stick to hands, remains soft for days and has a pleasant chocolate taste. Available in white and brown in packs of 6 Kg.

CODE	COLOUR
CIOCOPLASTBN	bianco white
CIOCOPLASTMR	marrone brown

Ciocoplast colours 1 kg

Ciocoplast colours è una gamma di colori vividi e intensi per decorare soggetti e preparazioni, con un notevole risparmio di tempo e grande omogeneità di risultato.

Ciocoplast colours offer a range of intense colours to decorate cakes with considerable time-saving and great colour uniformity.



CODE	COLOUR	
CIOCOPLASTWH	bianco white	<input type="checkbox"/>
CIOCOPLASTN*	nero black	<input type="checkbox"/>
CIOCOPLASTR*	rosso red	<input type="checkbox"/>

Easydecor 1 kg

Pasta di zucchero elastica e malleabile, leggermente aromatizzata alla vaniglia, adatta alle coperture e modellaggio in piano o tridimensionale, con l'aggiunta di zucchero a velo. Pronta all'uso, si stende facilmente con il mattarello. Disponibile in vari colori, si può anche utilizzare con coloranti idrosolubili Pavoni Italia.

Sugar paste extremely elastic and malleable, lightly flavoured with vanilla. It is extremely suitable for cake covering and flat modeling (for three-dimensional modeling is sufficient to harden the dough by adding sugar). Ready to use, it is easy to apply with a rolling pin. Available in various colours, it can be also coloured with water soluble Pavoni Italia colours.



CODE	COLOUR	
EASYBN	bianco white	<input type="checkbox"/>
EASYN	nero black	<input type="checkbox"/>
EASYAZ	azzurro light blue	<input type="checkbox"/>
EASYBL	blu blue	<input type="checkbox"/>
EASYR	rosso red	<input type="checkbox"/>
EASYFU	fucsia fuchsia	<input type="checkbox"/>

Real ghiaccia 3 kg



Prodotto in polvere che sostituisce la ghiaccia reale, migliorandone le prestazioni, miscelabile in acqua e subito pronto all'uso. Può essere applicato direttamente sulla torta mediante sac à poche, creando finissime decorazioni. Rispetto alla tradizionale ghiaccia, mantiene la sua elasticità nel tempo rendendo più semplice la gestione della torta durante tutte le fasi di lavorazione. Real ghiaccia può essere colorato utilizzando i colori idrosolubili Pavoni Italia. Disponibile anche nel formato da 500 gr.

Realghiaccia is a powdered product that replaces real icing and improves its performances. Ready to use after mixing with water. You can decorate your cakes with fine decorations by using it directly with a piping bag. Compared to traditional royal icing, Real ghiaccia maintains its elasticity as time goes by and make it easier to manage cake preparation during the whole processing. Real ghiaccia can be coloured by using the water soluble Pavoni Italia colours. Also available in 500 g size.

CODE

REALGHIACCIA

Massa Pavoni Summer 5 kg



Pasta di zucchero estremamente elastica e perfetta per la copertura, ha un aroma delicato e leggermente vanigliato. Non teme l'umidità e il clima caldo, non è sensibile agli sbalzi di temperatura e non crea condensa superficiale una volta estratta la torta dal frigorifero. Colore bianco candido.

Extremely elastic and perfect for covering, Massa Pavoni Summer has a soft taste, neutral with a vanilla hint. It resists at humidity and hot temperature. It does not fear moisture, temperature changes, it does not create surface condense once the cake gets out from refrigerator. Pure white colour.

CODE

MASSAPAVONISUMMER

Pastamica 5 kg



Pasta di zucchero da copertura. Estremamente malleabile, di colore bianco, leggermente aromatizzata alla vaniglia. Facilissima da stendere, crea una copertura perfetta senza crepe e bolle ed è ideale per le tue creazioni di cake design.

Pastamica is a sugar paste for covering. Extremely elastic in white colour, with a light vanilla hint. Extremely easy to spread, it creates a perfect covering, without breaks and bubbles. Ideal for your cake design creations.

CODE

PASTAMICA

Mix Macaron 500 g

Preparato per la realizzazione di macarons in modo semplice e veloce. Ideale da usare con i tappetini macaron Pavoni Italia.

Preparation ideal to create macarons in a simple and fast way. It can be used combined with Pavoni Italia macaron mats.



CODE

COLOUR

CODE	COLOUR	
MACARONBN	bianco white	<input type="checkbox"/>
MACARONG*	giallo yellow	<input type="checkbox"/>
MACARONR*	rosso red	<input type="checkbox"/>
MACARONRA	rosa pink	<input type="checkbox"/>
MACARONVR*	verde green	<input type="checkbox"/>
MACARONVL*	lilla lilac	<input type="checkbox"/>
MACARONCO*	marrone brown	<input type="checkbox"/>

Materie prime - Raw materials

AGAR AGAR 250 g

Per gelificare creme e liquidi. Vegetale, naturale, agente gelificante solubile al caldo. L'effetto gel si ottiene quando si raffredda. Sostituto della gelatina per dolci, pasticcini, dessert. La soluzione agar agar deve essere prima portata a ebollizione.

To gel creams and fluids. Vegetable, natural, heat-soluble gelling agent. The gel is obtained when cooled. Substitute of gelatine in confectionery, pastry, desserts. The agar agar solution must first be brought to the boil.

ZUCCHERO INVERTITO - INVERTED SUGAR 250 g

Utile per abbassare il punto di congelamento e mantenere umidi i prodotti da forno. Capace di mantenere l'umidità meglio del saccarosio: aumenta la morbidezza donando un gusto dolce più intenso.

To lower the freezing point and retain moisture of baked products. Able to retain moisture better than saccharose: improves softness with a more significant sweet taste.

HYFOAMA 250 g

Per montare soluzioni zuccherine calde e fredde. Per sostituire l'albume per ghiacce e meringhe.

To whip hot and cold sugar solutions. To substitute the egg white for icing and meringue.

GLICERINA - GLYCEROL/GLYCERIN 120 ml*

Ideale per rendere soffice la ghiaccia reale. Per reidratare la pasta di zucchero.

To soften the real icing. To rehydrate the sugar paste.

GOMMA XANTHANO - XANTHAN GUM 250 g

Utile a stabilizzare e addensare impasti privi di glutine o ispessire le salse.

To stabilize and thicken gluten free dough. To thicken sauces.

SCIROPPO DI GLUCOSIO - GLUCOSE SYRUP 250 g

Previene la congelazione di gelati e mousse e la cristallizzazione di praline e prodotti in cioccolato. Utile per preparare pasta di zucchero e cioccolato plastico.

To prevent freezing of ice cream and mousse. To prevent crystallization of pralines and other chocolate

products. To prepare sugar paste and plastic chocolate.

GOMMA ARABICA - ARABIC GUM 250 g*

Ottima per lucidare i petit four e per la preparazione di caramelle gommose.

To glaze petit fours. To prepare gummy candies.

GOMMA ADRAGANTE - TRAGACANTH GUM 250 g*

Ideale per impastare il pastigliaggio e la preparazione di caramelle gommose.

Used to mix sugar decorations and to prepare gummy candies.

CREMORTARTARO - CREAM OF TARTAR 250 g*

Utilizzato per invertire lo zucchero e far montare meglio l'uovo.

To invert sugar and better beat eggs.

PECTINA - PECTIN 1 Kg

Impiegata per gelificazione di gelatine di frutta.

Used to gelatinize fruit jellies.

SALI DI SILICIO - SILICON SALTS 1 Kg

Protegge dall'umidità le composizioni artistiche in zucchero colato e cioccolato.

To protect cast sugar and chocolate compositions from humidity.

BIOSSIDO DI TITANIO - TITANIUM DIOXIDE 250 g

Sbianca il cioccolato bianco e opacizza lo zucchero colato.

To whiten chocolate and matify cast sugar.

ACIDO TARTARICO - TARTARIC ACID 250 g*

Utilizzato per invertire lo zucchero.

To invert sugar.

ACIDO CITRICO - CITRIC ACID 1 Kg

Impiegato per invertire lo zucchero e aiutare la gelificazione delle gelatine di frutta.

To invert sugar and help the gelatinization of fruit jellies.

*fino a esaurimento
subject to availability

**EQU
IPM
ENT**



Storage & display







Covering

Covering è la serie di strumenti essenziali per il lavoro del pasticciere professionista. Materiale di alta qualità e resistenza e un design ideale per lo stoccaggio e la conservazione ottimale di ogni creazione. Covering è disponibile in due altezze, abbinabile al vassoio Tray e alle teglie 600x400 mm.

Plus:

- Inalterabile agli urti e alle basse temperature
- Sovrapponibile e inseribile
- Massima trasparenza
- Evita la condensa durante lo stoccaggio in frigoriferi e abbattitori

Covering is part of our line of essential tools for professional Pastry Chefs. High quality material and durability with the optimal design for the storage and perfect preservation of all your creations. Covering is available in two heights matching Tray item and 600x400 mm trays.

Plus:

- Can withstand impacts and low temperatures
- Stackable and nestable
- Fully transparent
- Prevents the condensation during the storage in the blast chillers

CODE	DIMENSION (mm)	
COVER55	585x390x55	Coperchio
COVER85	585x390x85	Coperchio
TRAY	590x395x28	Vassoio



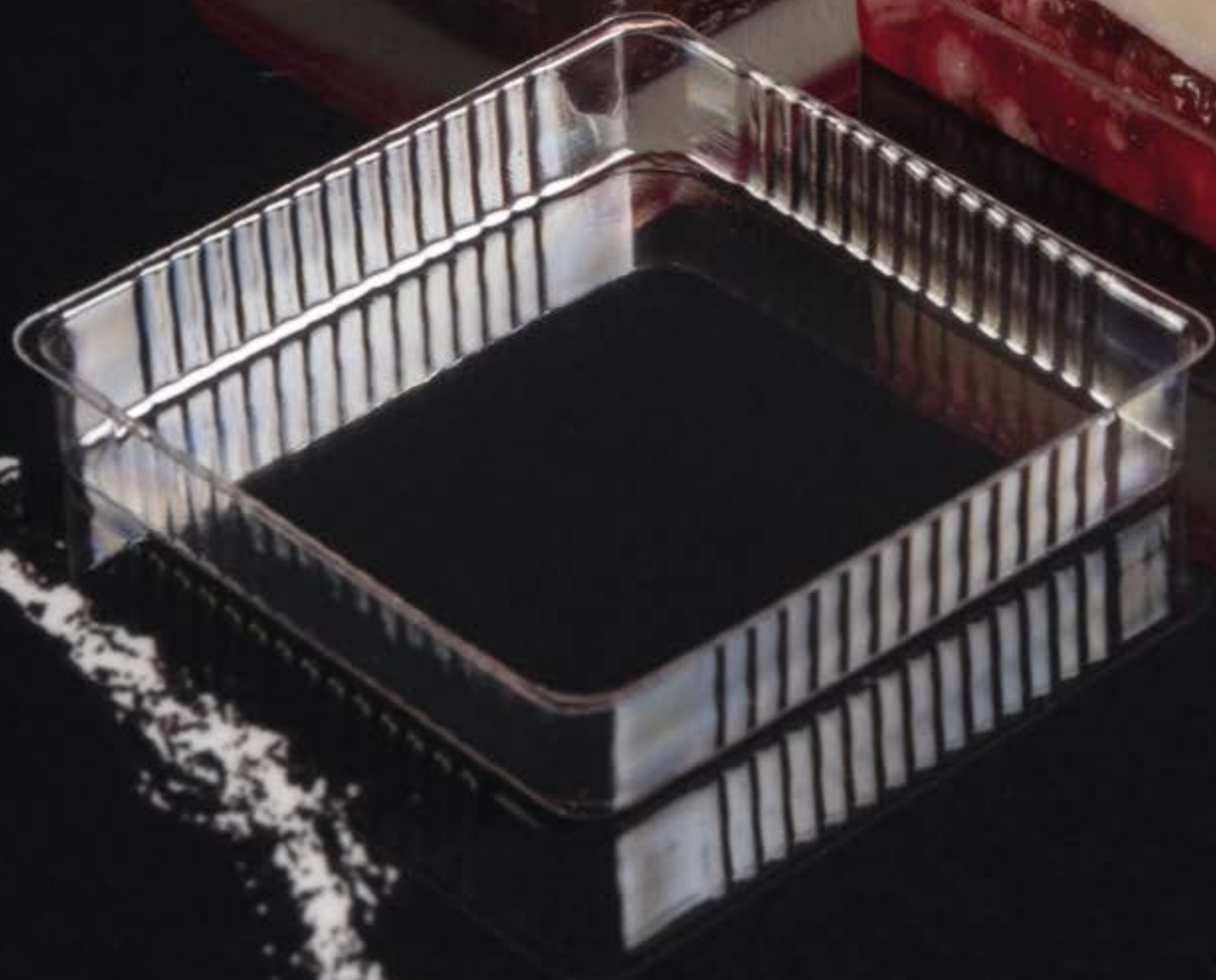

Vassoietti per mignon Trays for mignon

Il miglior modo per spostare, servire e presentare le tue preparazioni mignon. I vassoietti per Pavoflex mignon prodotti in materiale biodegradabile e sono totalmente trasparenti, resistenti all'umidità e non deformabili: perfetti per essere presi con le pinze e con le mani.

The best way to move, serve and present your mignon preparations. Our trays for mignon are made of biodegradable material, totally transparent, resistant to humidity, and non-deformable: perfect for gripping with tongs or by hand.

VM1B

Ø mm 42x8 h
tondo - round
Scatola da - Box of 2000 pcs



VM2B

mm 42x42x8 h
quadrato - square
Scatola da - Box of 2000 pcs



VM3B

mm 62x26x8 h
rettangolare - rectangular
Scatola da - Box of 2000 pcs





Vassoi per monoporzioni

Single-serving trays

Vassoi per monoporzioni: belli, pratici e indispensabili per servire al meglio le vostre creazioni. Disponibili nei colori bianco, nero, trasparente e, a richiesta, anche personalizzati.

Single-serving trays: beautiful, practical and must have to serve your creations at your best. Available in white, black and transparent colour, but also customized on demand.

NEW



VP2NR

mm 130x38
nero - black
Scatola da - Box of 250 pcs

VP2BN

mm 130x38
bianco - white
Scatola da - Box of 250 pcs

VP2T

mm 130x38
trasparente - transparent
Scatola da - Box of 250 pcs



VP1NR

mm 80x80
nero - black
Scatola da - Box of 250 pcs

VP1BN

mm 80x80
bianco - white
Scatola da - Box of 250 pcs

VP1T

mm 80x80
trasparente - transparent
Scatola da - Box of 250 pcs



VP3NR

Ø mm 80
nero - black
Scatola da - Box of 250 pcs

VP3BN

Ø mm 80
bianco - white
Scatola da - Box of 250 pcs

VP3T

Ø mm 80
trasparente - transparent
Scatola da - Box of 250 pcs



**VC1**

mm 140x40
oro - gold
Scatola da - Box of 200 pcs

**VC2**

mm 140x40
nero - black
Scatola da - Box of 200 pcs

**VC4**

mm 85x85x7 h
oro - gold
Scatola da - Box of 250 pcs

**VC5**

mm 85x85x7 h
nero - black
Scatola da - Box of 250 pcs

Scatole Packaging

Forme e misure differenti per il confezionamento delle tue preparazioni.

Various shapes and sizes to package your preparations.

**KS26**

mm 162x131x206 h
Confezione da 20 scatole
Box of 20 pcs

**KS49**

mm 143x72x12 h
Confezione da 100 scatole
Box of 100 pcs

KS32

mm 160x160x220 h
Confezione da 12 scatole
Box of 12 pcs

**KS38**

mm 140x180
Confezione da 40 scatole
Box of 40 pcs

A close-up photograph of a red silicone baking mat with a fine grid pattern. Several round, golden-brown cookies are scattered across the mat. The mat is placed on a wooden surface, and a metal cooling rack is visible at the bottom. The text 'Tappetini in silicone' and 'Silicone mats' is overlaid in white on a red background in the upper left corner.

Tappetini in silicone
Silicone mats





Forosil Strip

La praticità di Forosil, in formato striscia. Le Forosil Strip sono totalmente antiaderenti e la presenza dei microfori garantisce una migliore e più efficace distribuzione del calore. Utilizzate per foderare le fasce piene in acciaio inox: otterrai torte perfette e dalla facile sformatura, senza la necessità di ungerle! Si prestano all'impiego con torte da forno e lievitati. Sviluppate in collaborazione con Stefano Laghi.

The convenience of Forosil comes in strip. The Forosil Strips are totally non-stick and the micro-holes guarantee a better and more effective heat distribution. Use them to line the smooth stainless steel bands: you'll get perfect cakes, easy to unmold, without greasing before! You can use them for cakes to bake and leavened preparations. Developed in cooperation with Stefano Laghi.

	CODE	DIMENSION (mm)	PCS PER BOX
NEW	STRIP30FPC	635x280 h max	10
	STRIP40FPC	635x380 h max	10

abbinabile alle fasce lisce altezza 30-40 mm di pag 158
can be combined with the smooth bands height 30-40 mm see page 158





Forosil

Il migliore complemento alla teglia e griglia 600x400 mm. Forosil è il tappetino in silicone microforato perfettamente antiaderente. La presenza dei microfori facilita la distribuzione ottimale del calore.

The perfect complement to the 600x400 mm baking tray and grid. Forosil is a perfectly non-stick micro-perforated silicone mat. The micro-holes facilitate the optimal distribution of heat.



CODE	DIMENSION (mm)
------	----------------

FOROSIL43	385x285
------------------	---------

FOROSIL53	520x315
------------------	---------

FOROSIL64	585x385
------------------	---------

SPV

SPV è la linea di tappetini antiaderenti in silicone adatta sia per la cottura che la surgelazione di prodotti da pasticceria, gelateria, ristorazione e per l'industria dolciaria in genere. Ogni tappetino è realizzato in tessuto di vetro rivestito da silicone alimentare su entrambi i lati. SPV può essere utilizzato a temperature da -40°C a +250°C. Disponibile anche in versione macarons, utile a razionalizzare il lavoro di dosaggio.

SPV is the line of non-stick silicone mats suitable for both baking and freezing pastry, gelato, horeca and sweet industry goods. Each mat is made of fiberglass coated with food grade silicone on both sides and can be used at temperatures from -40°C to +250°C. Available also for macarons, to rationalize the dosing.

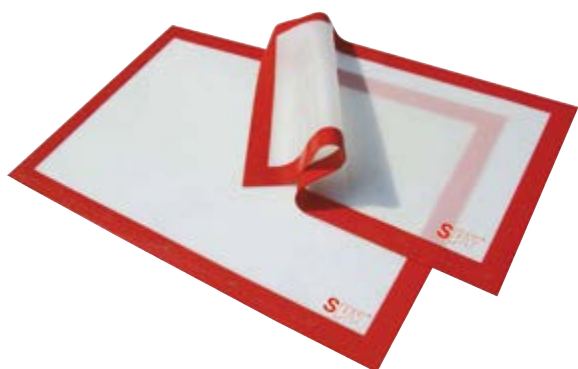

CODE	DIMENSION (mm)
------	----------------

SPV43	385x285
--------------	---------

SPV53	520x315
--------------	---------

SPV64	585x385
--------------	---------

SPV86	790x590
--------------	---------

SP6242	620x420
---------------	---------

SPV88	790x770
--------------	---------



CODE	DIMENSION (mm)
------	----------------

SPV64MACARONS	585x385
----------------------	---------

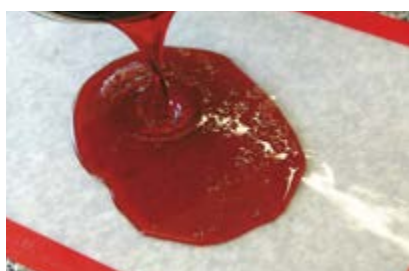

Attrezzature Tools





Fabrizio Donatone x GiroTray

La pasticceria a 360°. Letteralmente! Fabrizio Donatone, Campione del Mondo di Pasticceria nel 2015 a Lione, ha sviluppato insieme al team di ricerca Pavoni Italia un kit per panettoni e colombe... e non solo: è ideale anche per la cottura di croissant, pan di spagna, plumcake e altre preparazioni. Una soluzione tutto-in-uno, compatta e comoda, da sfruttare sempre.

Pastry at 360°, literally! Fabrizio Donatone, World Pastry Champion at Lyon in 2015, developed in collaboration with Pavoni Italia R&D team a kit for rotating and rising of panettone and colomba... and more: it is ideal for baking croissants, sponge cakes, plumcakes and many other preparations. A compact and handy solution, to take advantage of.



Guarda il video dedicato a **GiroTray** sul canale Youtube di Pavoni Italia

Watch the video **GiroTray** on Pavoni Italia's Youtube channel

Kit GiroTray

NEW

Il kit GiroTray si compone di una teglia 60x40 cm in alluminio con macrofori che consentono un passaggio ottimale del calore in cottura dei lievitati. Alla teglia, dotata di fori passanti sui lati, sono abbinati quattro spilloni che, entrando nella teglia dai fori e fissati con delle molle incluse nel kit, permettono di infilzare i prodotti da cuocere: panettoni di varie taglie, colombe e veneziane.

GiroTray kit is composed of a 60x40 cm aluminium tray with macro-holes to ensure optimal distribution of the heat while baking leavened preparations. The tray, with loops on the sides, is equipped with four forks. They enter the holes of the tray and fix thanks to the springs included in the kit, so they can hold the preparations: different sizes panettone, colomba and veneziana.

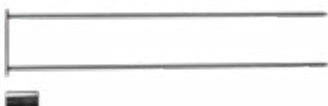
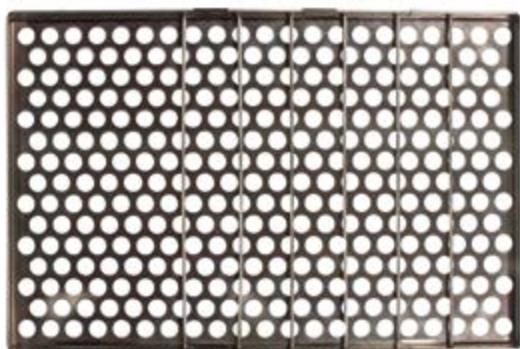

Il kit completo è composto da:

- 1 teglia piana in alluminio macroforata dimensioni 595x390x20 mm e spessore 15/10
- 4 spilloni in acciaio inox AISI304
- 4 molle ferma spilloni in acciaio AISI 304

The full kit is composed of:

- 1 flat aluminium tray with macro holes, size 595x390x20 mm and 15/10
- 4 AISI 304 steel forks
- 4 AISI 304 steel springs to fix the forks

CODE	DESCRIPTION
GIROTRAY	Kit completo Full kit
T64G	teglia piana in alluminio 595x390x20 mm spessore 15/10 flat aluminium tray with macro holes, size 595x390x20 mm and 15/10
SPILL2	2 spilloni in acciaio AISI 304 2 AISI 304 steel forks
KMS	10 molle ferma spilloni in acciaio AISI 304 10 AISI 304 steel springs to fix the forks

I componenti **T64G**, **SPILL2** e **KMS** sono acquistabili anche singolarmente.

*Items **T64G**, **SPILL2** and **KMS** can also be purchased individually.*

Con GiroTray puoi disporre i tuoi prodotti da lievitazione e fissarli alla teglia, portarli direttamente in cottura in forno e farli raffreddare sempre sulla teglia in carrelli o in abbattitore. Il fissaggio dei preparati è perfetto e possono essere disposti in diverse combinazioni, a seconda delle esigenze, per risparmiare tempo.

Un sistema unico, dove l'impiego della teglia permette la movimentazione da parte di un unico operatore e dove il lievitato non subisce stress da pinzatura e, una volta capovolto, mantiene una forma perfetta.

With GiroTray you can align and fix your preparations on the tray, put them directly in the oven and let them cool on the trolleys or in the blast chiller without removing the tray. Preparations can be fixed on the tray in many combinations, according to needs and with time saving.

A unique system, where the use of the tray enables the handling by a single operator and the leavened products don't get stressed by the stapling, keeping a perfect shaped once overturned.

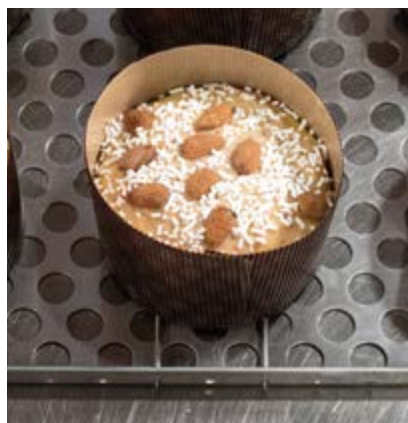

GiroTray è ideale in pasticcerie e laboratori dove serve ottimizzare lo spazio con una soluzione compatta, utile non solo a Natale e a Pasqua, ma durante tutto l'anno. La teglia, abbinata al tappetino Forosil, è perfetta per la cottura di croissant e viennoiserie in virtù di una ventilazione ottimale. Può essere utilizzata anche insieme agli stampi in silicone, grazie ai macrofori che permettono un più facile e adeguato passaggio del calore in modo da facilitare la cottura nello stampo.

GiroTray is ideal for pastry shops and labs where compact solutions are useful to save space, not just at Christmas and Easter time, but all year long. The tray, combined with Forosil mat, is perfect for baking croissants and viennoiserie thanks to an ideal air circulation, but it can also be used in combination with silicone moulds, thanks to the macro-holes that allow an easier and adequate heat distribution, to ease the baking within the mould.



Gira panettoni GiraTu - Turn panettoni GiraTu

Facile da impilare sia sui carrelli che sulle rastrelliere, è realizzato in acciaio inox AISI 304 e ha un'impugnatura ergonomica. Adatto al contatto alimentare.

Easy to stack on both trolleys and racks, it's made of AISI 304 stainless steel and has an ergonomic handle. Suitable for food contact.

CODE	DIMENSION (mm)
GIRATU150	1500
GIRATU200	2000
GIRATU225	2250



Gira panettoni Girolo - Turn panettoni Girolo

Gira panettoni sovrapponibile ideato per risolvere i problemi di spazio nei laboratori, agganciando contemporaneamente diverse pezzature di panettoni, colombe, veneziane etc. Può essere utilizzato da una sola persona, senza alcun aiuto, riuscendo a sovrapporre più telai fino a 150 kg di panettoni. Realizzato in acciaio inox.

Stackable and space-saver Gira panettoni. It allows to hang many panettoni, colombe and veneziane. It requires just one person. It can stack many trays, till 150 kg of panettoni. Made of stainless steel.

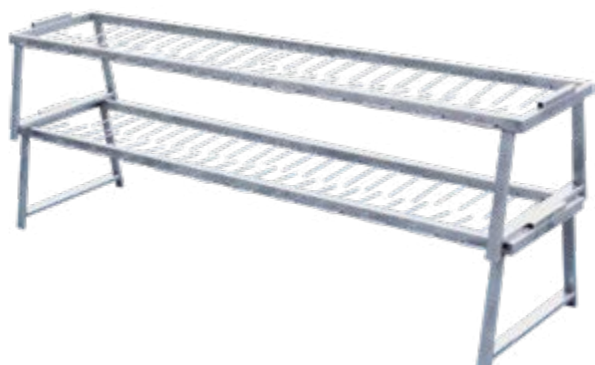

CODE	DIMENSION (mm)
GIROIO P	1650x380
GIROIO G	2150x380

Pro Series

Una nuova linea di attrezzature curata nei minimi dettagli. Materiali scelti con attenzione, soluzioni attente per migliorare il tuo lavoro e tutta l'esperienza Pavoni Italia dedicata al mondo dei professionisti della pasticceria e del dolce.

A new line of equipment with the utmost attention to detail. Carefully chosen materials, thoughtful solutions to improve your work, and all of Pavoni Italia's experience dedicated to the world of pastry professionals.

Fruste / Whisks

NEW



Manico extra-grip
Extra-grip handle

Acciaio flessibile e indeformabile
Shape-retaining and flexible steel

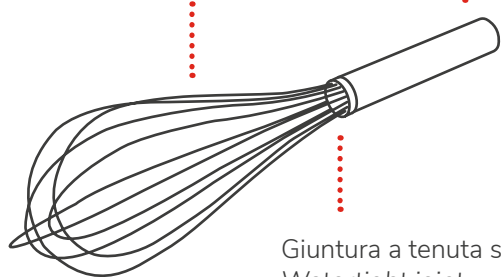

Giuntura a tenuta stagna
Watertight joint



CODE	LUNGHEZZA LENGTH (mm)	LUNGHEZZA MANICO HANDLE LENGTH (mm)
FT250	250	105
FT350	350	135
FT450	450	205

La migliore manovrabilità per grandi risultati. Le fruste Pro Series sono in acciaio inox armonico indeformabile, appositamente studiato per avere la corretta flessibilità e capacità di tornare sempre alla forma originaria. Manico isolante resistente anche alle alte temperature (fino a 220°C).

The best manoeuvrability for the best results. The Pro Series whisks are made of harmonic stainless steel, specially designed to provide optimum flexibility and the ability to always return to their original shape. Insulating extra-grip handle and high-temperature resistant (up to 220°C).



Spatole / Spatulas

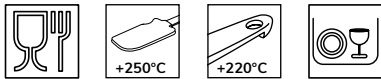
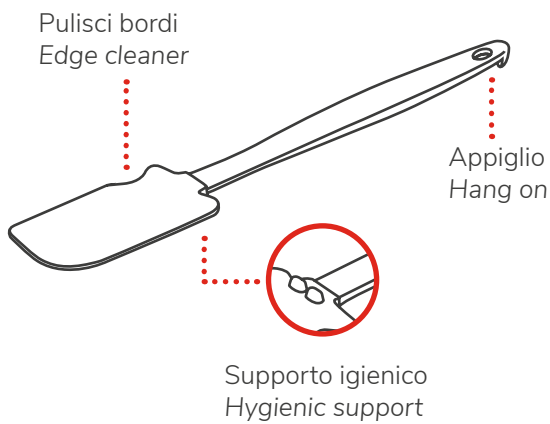

NEW

CODE	LUNGHEZZA LENGTH (mm)	LUNGHEZZA MANICO HANDLE LENGTH (mm)
SP300	360	250
SP301	260	170

Realizzate in silicone platinico resistente fino a 250°C. I piccoli dettagli fanno la differenza: appiglio "hang on" per un comodo appoggio durante le lavorazioni, incavo pulisci bordi per raccogliere al meglio le preparazioni e manico extra-grip, resistente fino a 220°C, per la migliore maneggevolezza. La giunzione tra paletta e manico è senza fessure, ultra resistente, per maggiore igiene e durata.

Made of platinum silicone, resistant up to 250°C. Small details that make the difference: "hang on" handle for an easy support during the preparations, edge cleaner groove to scrape the mixture and extra-grip handle, resistant up to 220°C, for the best ease of use. The joint between the blade and the handle is watertight, ultra resistant for the best hygiene and longevity.

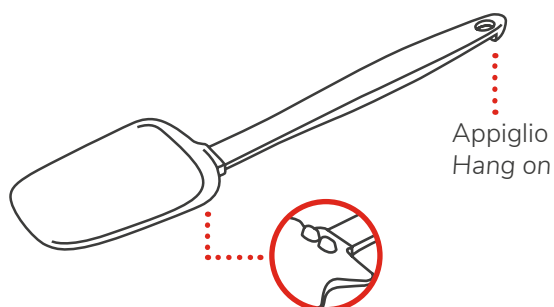

Cucchiaini / Spoons

NEW

Supporto igienico
Hygienic support

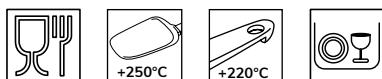

CODE	LUNGHEZZA LENGTH (mm)	LUNGHEZZA MANICO HANDLE LENGTH (mm)
SP302	380	250
SP303	270	170

Nuove soluzioni pensate per gli utilizzatori Pro: realizzazione in silicone platinico resistente fino a 250°C, sostegno igienico per evitare contaminazioni e appiglio "hang on" per un comodo appoggio durante le lavorazioni. Manico ergonomico extra-grip, resistente alle alte temperature (220°C) e giunzione fra paletta e manico ultra resistente, per maggiore igiene e durata.

New solutions for the Pro users: made of platinum silicone resistant up to 250°C, hygienic support to avoid contaminations and "hang on" handle for an easy support during the preparations. Ergonomic handle with extra-grip, resistant to high temperatures (220°C) and watertight joint between silicone and handle for the best hygiene and longevity.





Élite

Sac à poche monouso - Disposable piping bags

Élite è il sacchetto monouso in materiale multistrato che conferisce al prodotto resistenza, flessibilità e sicurezza igienica. La sua superficie interna liscia facilita la fuoriuscita del prodotto. All'esterno il suo speciale materiale "soft touch" antiscivolo consente un'ottima presa e facilità d'impiego anche con le mani bagnate.

Élite is a disposable piping bag made of multilayer material, resistant, flexible and hygienically safe. It is smooth on the inside, in order to ensure an easier product outflow. Moreover, the special "soft touch" grip on the outside enables a perfect hold and a very easy grip, even with wet hands.



CODE	DIMENSION (mm)	SPESSORE THICKNESS (µm)	PCS PER BOX
ELITE45	460x280	80	100
ELITE55	530x280	80	100
ELITE60	600x280	80	100



Powerflex

Powerflex è il sac à poche in 3 misure, resistente e realizzato in gomma alimentare, che lascia al pasticcere grande sensibilità di lavorazione. Non trasuda ed è perfettamente saldato nei giunti per evitare infiltrazioni. Facile da pulire, si può mettere in lavastoviglie. Non assorbe gli odori, ha un ottimo grip antiscivolo e lavora bene anche con composti molto duri (non deforma lateralmente). Il foro che ospita la bocchetta non si deforma nel tempo anche se sottoposto a sforzi.

Powerflex is a durable piping bag made of food-grade rubber. It is available in three different sizes and is individually packaged. It does not exude, even when using fatty ingredients and guarantees excellent responsiveness, as it is extremely soft and easy to handle. Perfectly sealed at the joints to avoid leaks, it is easy to clean even if the ingredients are left to dry, and can be put in the dishwasher. It does not absorb odours from the ingredients, has an excellent non-slip grip and resists well to hard squeezing with very dense mixtures (it does not warp sideways). The tip hole does not lose its shape over time, even under pressure.



CODE	LUNGHEZZA LENGTH (mm)	PCS PER BOX
PW040	400	1
PW045	450	1
PW050	500	1



Sac à poche - Piping bags

Sac à poche multiuso in tela plastificata comodo e resistente senza cuciture, provvisto di asola.

Made of plastic canvas and seamless; it is provided with tip hole.



CODE	LUNGHEZZA LENGTH (mm)	PCS PER BOX
14010	280	1
14020	340	1
14030	400	1
14040	460	1
14050	500	1
14060	550	1
14070	600	1
14080	650	1
14090	700	1

Vaso portasacchetto - Bag-sustaining jar



CODE	Ø (mm)	ALTEZZA HEIGHT (mm)
34013	195	230

Bocchette in acciaio - Stainless steel piping tips

Decine di forme, tipologie e misure. Le bocchette Pavoni Italia sono indispensabili per dare il tocco finale ad ogni tipo di decorazione. Disponibili in acciaio e policarbonato, permettono di ottenere risultati perfetti ad ogni utilizzo.

Dozens of shapes, types and sizes. Pavoni Italia tips are a must for giving that final touch to any type of decoration. Available in stainless steel and polycarbonate, they allow you to obtain perfect results every time you use them.

Tonda / Round



CODE	Ø (mm)	ALTEZZA HEIGHT (mm)
125/2	2	43
125/4	4	43
125/6	6	43
125/8	8	43
125/10	10	43

CODE	Ø (mm)	ALTEZZA HEIGHT (mm)
125/12	12	43
125/14	14	43
125/16	16	43
125/18	18	43
125/20	20	43

Stella punta fine / Small star



CODE	Ø (mm)	ALTEZZA HEIGHT (mm)
126/2	2	52
126/4	4	52
126/6	6	52
126/8	8	52
126/10	10	52

CODE	Ø (mm)	ALTEZZA HEIGHT (mm)
126/12	12	52
126/14	14	52
126/16	16	52
126/18	18	52
126/20	20	52

Stella punta larga / Large star



CODE	Ø (mm)	ALTEZZA HEIGHT (mm)
127/2	2	52
127/4	4	52
127/6	6	52
127/8	8	52
127/10	10	52

CODE	Ø (mm)	ALTEZZA HEIGHT (mm)
127/12	12	52
127/14	14	52
127/16	16	52
127/18	18	52
127/20	20	52

Fiore / Flower



CODE	Ø (mm)	ALTEZZA HEIGHT (mm)
128/2	2	52
128/4	4	52
128/6	6	52
128/8	8	52
128/10	10	52

CODE	Ø (mm)	ALTEZZA HEIGHT (mm)
128/12	12	52
128/14	14	52
128/16	16	52
128/18	18	52
128/20	20	52

Delizia / Delizia



CODE	Ø (mm)	ALTEZZA HEIGHT (mm)
131/10	10	40
131/12	12	40
131/14	14	40
131/16	16	40

CODE	Ø (mm)	ALTEZZA HEIGHT (mm)
131/18	18	40
131/20	20	40
131/22	22	40

St. Honoré / St. Honoré



CODE	Ø (mm)	ALTEZZA HEIGHT (mm)
133/20	20	50
133/25	25	50
133/30	30	50

CODE	Ø (mm)	ALTEZZA HEIGHT (mm)
133/35	35	50
133/40	40	50

Bocchette in policarbonato - Polycarbonate piping tips

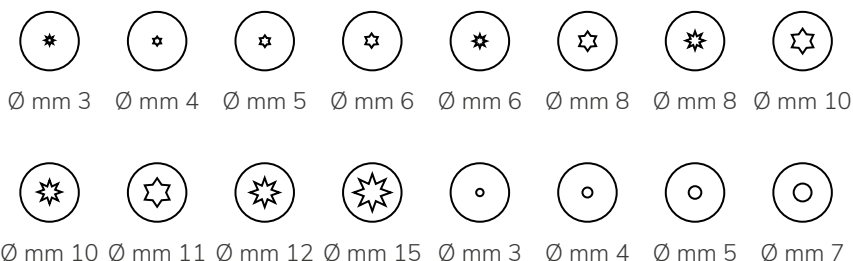

PB24

Kit 24 bocchette - Kit 24 piping tips
h bocchette - h tips 55 mm

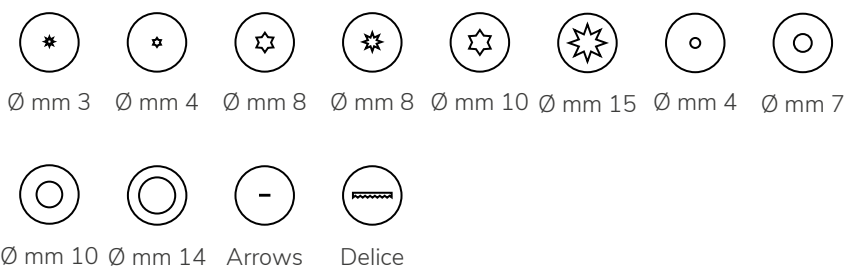
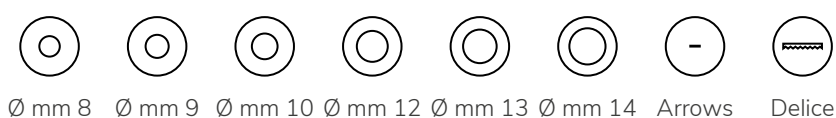

PB12

Kit 12 bocchette - Kit 12 piping tips
h bocchette - h tips 55 mm

Griglia per il glassaggio - Glazing grid



Griglia 600x400 mm per il glassaggio di torte e monoporzioni. Di misura perfettamente compatibile con teglie, vassoi Covering e i tappetini SPV in silicone, vanta una base rialzata per facilitare il processo di glassaggio. Realizzata in acciaio AISI 304 è resistente e semplice da pulire.

600x400 mm grid for glazing cakes and single-serving portions. It perfectly fits trays, included the Covering range, and SPV silicone mats. It has a raised base which allows to easily glaze your creations.

Made of AISI 304 steel, it is resistant and easy to clean.

CODE	DIMENSION (mm)
GLA64	600x400

Bobine in PVC - PVC rolls

Bobina in PVC ad uso alimentare, ideale per rivestire i bordi degli stampi e delle sagome in metallo. Permette il facile distacco delle preparazioni dagli stampi senza rovinare i bordi.

PVC roll for food use, ideal for covering the edges of moulds and metal shapes. It makes removal of the mixtures from the moulds easy without damaging the edges.



CODE	ALTEZZA HEIGHT (mm)
BB25	25
BB30	30
BB35	35
BB4	40

CODE	ALTEZZA HEIGHT (mm)
BB45	45
BB5	50
BB6	60

Fogli in PVC - PVC sheets

Una perfetta barriera antiaderente per realizzare e sformare preparazioni dolci e semifreddi, utilizzando gli stampi e le sagome in acciaio. Ideale anche per la lavorazione del cioccolato e per realizzare originali decori. Non utilizzabili in cottura.

A perfect non-stick barrier designed to help make and remove desserts and semifreddo creations when using steel moulds and bands. Ideal also for working with chocolate and for creating original decorations. Not suitable for baking.



CODE	DIMENSION (mm)	SPESSORE THICKNESS (µm)	PCS PER BOX
FA64	600x400	100	100

Pavoflon

Realizzato in teflon, può essere utilizzato per un'innumerabile quantità di cotture mantenendo sempre un'antiaderenza formidabile, specialmente con prodotti da forno ad alta percentuale di zuccheri. È ideale per cuocere gli impasti, per la produzione di pane precotto surgelato in diverse forme e dimensioni. Utilizzabile sia in forni elettrici che ventilati, oppure in tunnel, a temperature che vanno da -40°C a +350°C. Non è necessario ingrassare Pavoflon. Lavalo con acqua tiepida e una spugna morbida e non utilizzare detergenti abrasivi.

Made of non-stick teflon, it can be used many times without losing its excellent non-stick features, even with products containing a high percentage of sugar. It's excellent for cooking doughs, for the production of precooked and frozen bread. Pavoflon can be used in electric and ventilated ovens or in industrial tunnels, at temperatures from -40°C to +350°C. No need to grease. Wash Pavoflon with warm water and a soft sponge. Do not use abrasive detergents.



CODE	DIMENSION (mm)
------	----------------

PVF0600400	600x400
-------------------	---------

Altri formati personalizzati sono disponibili su misura / Quantità min. di 20 fogli

Customizable formats on request / Minimum quantity 20 sheets

Stampi per pane - Bread moulds



NIDODAPE

Nido d'ape
Honeycomb

mm 140x100



TARTARUGA

Tartaruga
Turtle

mm 140x100

Decora crostate - Tarts decorator























DCR

Ø mm 300

Stampi in plastica per monoporzioni

Plastic moulds for single-serving portions













CODE	STAMPO MOULD	STAMPO MOULD DIM. (mm)	STAMPI PER VASSOIO MOULDS PER TRAY	PORTION (g)	VASSOIO TRAY DIM. (mm)	CODE ESTRATTORE DEMOULDER	CODE TAGLIAPASTA CUTTER
TTS		Ø 67x40 h	35	~75	600x400	ETS	CTS
TTS2			20		400x340		
TES		65x65x40 h	35	~75	600x400	EES	CES
TES2			20		400x340		
TTRS		76x69x40 h	35	~75	600x400	ETRS	CTRS
TTRS2			20		400x340		
TCS		74x71x40 h	35	~75	600x400	ECS	CCS
TCS2			20		400x340		
TOS		86x50x40 h	35	~75	600x400	EOS	COS
TOS2			20		400x340		
TTNS		74x68x40 h	35	~75	600x400	ETNS	CTNS
TTNS2			20		400x340		
TGS		90x58x40 h	35	~75	600x400	EGS	CGS
TGS2			20		400x340		
TVS		88x60x40 h	35	~75	600x400	EVS	CVS
TVS2			20		400x340		
TRS		76x51x40 h	35	~75	600x400	ERS	CRS
TRS2			20		400x340		
TQS		59x59x40 h	35	~75	600x400	EQS	CQS
TQS2			20		400x340		

Stampi in plastica per mignon

Plastic moulds for mignon



CODE	STAMPO MOULD	STAMPO MOULD DIM. (mm)	STAMPI PER VASSOIO MOULDS PER TRAY	PORTION (g)	VASSOIO TRAY DIM. (mm)	CODE ESTRATTORE DEMOULDER	CODE TAGLIAPASTA CUTTER
TMTS		Ø 44x25 h	96	~20	600x400	EMTS	CMTS
TMTS2			64		400x340		
TMES		42x42x25 h	96	~20	600x400	EMES	CMES
TMES2			64		400x340		
TMTRS		50x44x25 h	96	~20	600x400	EMTRS	CMTRS
TMTRS2			64		400x340		
TMCS		48x46x25 h	96	~20	600x400	EMCS	CMCS
TMCS2			64		400x340		
TMOS		55x35x25 h	96	~20	600x400	EMOS	CMOS
TMOS2			64		400x340		
TMTNS		47x44x25 h	96	~20	600x400	EMTNS	CMTNS
TMTNS2			64		400x340		
TMGS		60x38x25 h	96	~20	600x400	EMGS	CMGS
TMGS2			64		400x340		
TMVS		60x38x25 h	96	~20	600x400	EMVS	CMVS
TMVS2			64		400x340		
TMRS		51x31x25 h	96	~20	600x400	EMRS	CMRS
TMRS2			64		400x340		
TMQS		38x38x25 h	96	~20	600x400	EMQS	CMQS
TMQS2			64		400x340		

Placche per pastafrolla - Plastic cutter grids

Ideali per biscotti, pizzette, salatini e basi per pasticcini, velocizzano il lavoro in laboratorio senza rinunciare alla fantasia. Disponibili in tante forme diverse.

Suitable to prepare cookies, pizzas, savoury biscuits and pastry bases. Time-saving without any compromise with fantasy. Available in many shapes.



CODE	STAMPO MOULD	MAX DIM. (mm)	N. STAMPI N. MOULDS
PF1		90	20
PF2		45	72
PF2A		40	95
PF3		53	53
PF3A		40	95
PF4		60	63
PF4A		40	95
PF5		45	60
PF5A		40	95
PF6		48	95
PF6A		40	116
PF7		48	78
PF7A		40	128
PF8		50	68
PF8A		40	105
PF9		80 66	50





CODE	STAMPO MOULD	MAX DIM. (mm)	N. STAMPI N. MOULDS
PF10		60	36
PF10A		51	70
PF11		60	50
PF12		60	55
PF13		60 50	28 36
PF14		75 80	20 16
PF15		65 63	20 25
PF18		75 70	16 25
PF300		45 52 50 56 57	64

Chablon da forno 600x400 mm - Baking chablon 600x400 mm



Realizzati in silicone, spessore 4 mm. Metti la teglia con lo chablon direttamente in forno, lo chablon non permetterà all'impasto di dilatarsi durante la cottura, producendo forme perfette.

Silicone made, thickness 4 mm. Pour the mixture in the holes and level it, put the tray with the chablon in the oven and bake it. The chablon will not allow the product to expand and you will get perfect shapes.

CODE	STAMPO MOULD	DIM. (mm)	IMPRONTE INDENTS	CODE	STAMPO MOULD	DIM. (mm)	IMPRONTE INDENTS
CHT		Ø 35	96	CHC		40x35	88
CHQ		35x35	96	CHO		40x30	99

Stampi in silicone per gelatine - Silicone jelly moulds



TG1002

Mezza sfera
Hemisphere

Ø mm 27x13,5 h

24 impronte
24 indents



TG1021

Pera
Pear

mm 40x26x15 h

24 impronte
24 indents

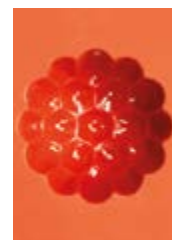

TG1009

Mora
Blackberry

Ø mm 30x24 h

24 impronte
24 indents

Dimensione stampo: mm 340x183x30 h - Mould size: mm 340x183x30 h

Stampo per cannoli in banda stagnata Tin plate "Cannoli" mould



CODE	DIM. (mm)	Ø (mm)
41A	120	30
41B	140	35
41C	160	40



CODE	DIM. (mm)	Ø (mm)
40A	130	20
40B	180	12
40C	290	27

Molle per dolci - Pincers



CODE	LUNGHEZZA LENGTH (mm)
MD1*	165



CODE	LUNGHEZZA LENGTH (mm)
MD2*	180



CODE	LUNGHEZZA LENGTH (mm)
PD1*	185

*fino ad esaurimento
subject to availability

Mestoli inox - Stainless steel ladles



CODE	LUNGHEZZA LENGTH (mm)	Ø (mm)	CAPACITY (l)
ME6	300	65	0,07
ME10	370	100	0,25
ME12	400	120	0,50

Schiumarole inox - Stainless steel skimmers



CODE	DIMENSION (mm)	Ø (mm)
SCR16	400	160
SCR18	400	180
SCR20	500	200
SCR24	500	240
SCR28	500	280

Raschietti - Scrapers



Personalizzabili con logo cliente.
Customizable with customer logo.

Un'ampia varietà di raschietti di differenti forme e profili, adatti a molteplici lavorazioni in cucina.

A wide variety of scrapers of different shapes and profiles, suitable for multiple applications in the kitchen.



CODE	DIMENSION (mm)
RA1RS	120x80



CODE	DIMENSION (mm)
RA2RS	120x80



CODE	DIMENSION (mm)
RA3RS	121x81



CODE	DIMENSION (mm)
RA5RS	145x99



CODE	DIMENSION (mm)
RA4RS	148x99



CODE	DIMENSION (mm)
RA6RS	110x80



CODE	DIMENSION (mm)
RA7RS	216x128



CODE	DIMENSION (mm)
RA8RS	216x128



CODE	DIMENSION (mm)
RA9RS	208x128



CODE	DIMENSION (mm)
RA10RS	198x148



CODE	DIMENSION (mm)
SRP	265x125

Raschie in acciaio - Tempered harmonic steel scrapers



CODE	LUNGHEZZA LENGTH (mm)
RM13	130
RM16	160
RM18	180
RM20	200

CODE	LUNGHEZZA LENGTH (mm)
RM22	220
RM24	240
RM28	280

Spatole e coltelli - Spatulas and knives



CODE	LUNGHEZZA LENGTH (mm)
CM67799	250



CODE	LUNGHEZZA LENGTH (mm)
PM64025	250



CODE	LUNGHEZZA LENGTH (mm)
CM64095	150
CM64100	200
CM64105	250
CM64110	300



CODE	LUNGHEZZA LENGTH (mm)
PM64012	250
PM64010	170
PM64005	110



CODE	LUNGHEZZA LENGTH (mm)
PM54128	80
PM54129	100
PM54130	120



CODE	LUNGHEZZA LENGTH (mm)
CM67785	240



CODE	LUNGHEZZA LENGTH (mm)
CM67777	240
CM67791	320
CM67793	360
CM67781	300



CODE	LUNGHEZZA LENGTH (mm)
CM67737	240
CM67739	260
CM67741	300
CM67743	340

Le misure dei coltelli e delle spatole sono relative alla lama
Dimensions of knives and spatulas are related to blades length

Set tagliapasta - Cutters kit

	CODE	STAMPO MOULD	STAMPI PER KIT MOULDS PER KIT	DIMENSION (mm)
	STP53B	cerchi lisci smooth circle	9	da - from 20 a - to 80
	STP52B	cerchi festonati festooned circle	9	da - from 20 a - to 80
	STP540B	cerchi lisci robusti strong smooth circle	12	da - from 22 a - to 110
	STP52D	cerchi festonati festooned circle	14	da - from 20 a - to 105
	STP54B	cerchi festonati robusti strong festooned circle	12	da - from 20 a - to 110
	STP61B	ovali lisci smooth oval	9	da - from 27 a - to 85
	STP59	quadrati lisci smooth square	6	da - from 30 a - to 65
	STP58N	quadrati festonati festooned square	5	da - from 35 a - to 80
	STPROML	rombo liscio smooth rhombus	5	da - from 50 a - to 115
	STP55L	esagono liscio smooth hexagon	6	da - from 45 a - to 90
	STP57	goccia liscia smooth drop	6	da - from 45 a - to 95
	STP64	cuore liscio smooth heart	6	da - from 40 a - to 80
	STP65	stella liscia smooth star	6	da - from 45 a - to 85
	STP54L	mezzaluna liscia smooth half-moon	6	da - from 30 a - to 65
	STP67	fiore liscio smooth flower	6	da - from 40 a - to 95
	STP63	foglia liscia smooth leaf	6	da - from 50 a - to 95
	STP31	animali animals	10	
	STP44	forme Natale Christmas shapes	4	
	STP33	lettere letters	26	
	STP34	numeri numbers	9	
	STP46	sagome diverse different shapes	8	
	STP30D	sagome diverse different shapes	12	
	STP00	sagome diverse different shapes	6	

Tagliapasta - Pastry cutters

Rotelle tagliapasta Pastry cutters



CODE	Ø (mm)	LAMA BLADE
TP5	55	liscia - smooth
TP6	55	festonata - festooned
TP7	97	liscia - smooth

Taglia croissant Croissant cutters



CODE	DIM TAGLIO - CUT (mm)
RC1	70x100
RC2	110x150
RC3	180x140
RC4	180x200
RC5	140x200
RC6	55x70

Tagliapasta estensibili inox Stainless steel extensible pastry cutters



CODE	Ø (mm)	LAMA BLADE
TP01	55	5 lisce - smooth
TP02	55	7 lisce - smooth
TP03	55	5 lisce - smooth 5 festonate - festooned
TP04	55	7 lisce - smooth 7 festonate - festooned

Rulli taglia o forapasta

Pastry dockers



CODE	DIMENSION (mm)
RP1	120



CODE	DIMENSION (mm)
RP2	65



CODE	DIMENSION (mm)
RP3	120



CODE	DIMENSION (mm)
RP4	65



CODE	DIMENSION (mm)
RP5	65

Palette inox per gelato - Stainless steel ice cream spatulas



CODE	LUNGHEZZA LENGTH (mm)
PG7	250
PG8	300



CODE	LUNGHEZZA LENGTH (mm)
PG3*	250
PG4*	300



CODE	LUNGHEZZA LENGTH (mm)
PG7TR	250

*fino ad esaurimento
subject to availability

Sessole - Scoops

Sessole alluminio Aluminium scoops



CODE	CAPACITY (l)
SEM100	0,1
SEM300	0,3
SEM500	0,5

CODE	CAPACITY (l)
SEM1000	1
SEM1500	1,5
SEM2000	2

Sessole in plastica Plastic scoops



CODE	CAPACITY (l)
SES25	0,025
SES50	0,05
SES100	0,10

CODE	CAPACITY (l)
SES250	0,25
SES500	0,5
SES1000	1



CODE	CAPACITY (l)
SET150	0,15
SET250	0,25
SET500	0,5

CODE	CAPACITY (l)
SET750	0,75
SET1000	1
SET2000	2

Bottiglia - Bottle



Personalizzabile con logo cliente.
Customizable with customer logo.



CODE	CAPACITY (l)
BOTTIGLIA	1

Caraffe - Jugs



CODE	CAPACITY (l)
CAG05	0,5
CAG1	1
CAG2	2

CODE	CAPACITY (l)
CAG3	3
CAG5	5

Imbuti in plastica - Plastic funnels



CODE	Ø (mm)
IMB8	80
IMB10	100
IMB12	120

CODE	Ø (mm)
IMB14	140
IMB18	180

Colino a pistone inox - Stainless steel piston funnel



CODE
COLINO

Setacci - Sieves



CODE	Ø (mm)	ALTEZZA HEIGHT (mm)	RETE NET MESHES (mm)
SETACCIOP05	240	80	0,5
SETACCIOP1	240	80	1
SETACCIOG05	300	90	0,5
SETACCIOG1	300	90	1

Spargifarina inox - Flour and sugar stainless steel sifter



CODE	RETE NET MESHES (mm)
SF1M	1

Apriscatole professionale - Professional tin opener



CODE
AP1

Termometri - Thermometers



CODE	MEASURING RANGE (°C)	
TH5986S	from -50 to +260	Lettura immediata, sonda cavo, memorie. Immediate reading, probe, memories.



CODE	MEASURING RANGE (°C)	
TH5989	from -50 to +150	Lettura immediata, sonda fissa in acciaio inox. Fixed stainless steel probe, immediate reading.

Spazzole - Brushes



CODE	DIMENSION (mm)	
SP1	430	setola in crine - horsehair bristle



CODE	DIMENSION (mm)	
SP2	300	ottone e misto - brass and other materials
SP3	300	ottone - brass

Pennelli per dolci - Brushes



CODE	DIMENSION (mm)
34063	40
43753	60
43763	75

Guanti - Gloves

Guanti anticalore - Heat-resistant gloves

Resistenza al calore per contatto fino a 350°C per 20 secondi.

It can withstand contact with temperatures up to 350°C for 20 seconds.



CODE	LUNGHEZZA LENGTH (mm)
GUANTO/A	150

Guanto in silicone - Silicone glove

Protegge dalle temperature fino a +250°C.

It protects you against temperatures up to +250°C.



CODE

CHELATBL CHEF

Vassoi da esposizione - Display trays



CODE **DIMENSION (mm)**

VE1A 305x225x20 h

VE2A 375x245x20 h



CODE **DIMENSION (mm)**

VE1 305x225x20 h

VE2 375x245x20 h

alluminio oxalizzato
oxalate aluminium



CODE **DIMENSION (mm)**

VE1G 305x225x20 h

VE2G 375x245x20 h

alluminio oxalizzato versione oro
oxalate aluminium golden version

Bacinelle inox fondo piatto - Stainless steel flat bottom bowls



CODE **Ø (mm)** **ALTEZZA
HEIGHT (mm)** **CAPACITY (l)**

BL17* 155 90 1

BL21* 190 115 2

BL24* 220 120 3

BL29* 270 135 5

BL30* 290 150 6

BL31* 305 170 8

BL36* 355 185 11

*fino ad esaurimento
subject to availability

Kit aerografo - Airbrush kit

Kit composto da aeropenna a doppia azione completamente in acciaio inox, tubo in gomma con attacchi rapidi, compressore 220 volt, motore non a bagno d'olio e quindi idoneo al contatto con sostanze alimentari. Pressione di uscita 2,5 bar.

Composed by stainless steel made double action airbrush, hose (no clamp is needed), compressor 220 volt, with non oil engine suitable for foods, outgoing pressure 2,5 bar.



CODE

AEROGRAFO

CODE

RG2

Sostegno per aeropenna - Airbrush support

AEROPENNA

Pistola alimentare - Food spray gun

Ideale per erogare ogni liquido a media e bassa viscosità come burro, olio, gelatina, salse, ecc. e per spruzzare superfici piane e oggetti come leccarde o vassoi.

Ideal to spray low to medium viscosity liquids including butter, oil, jelly and sauces etc. and spray flat surfaces and objects like trays and pans.



CODE	CAPACITY (l)	PRESSIONE MAX DINAMICA MAX DYNAMIC PRESSURE (bar)	POTENZA POWER (V)	POTENZA NOMINALE RATED POWER (W)
W200	0,7	160	220	60

Pettini - Combs

Pettine Charlotte - Charlotte comb

Pettine Charlotte con telaio, in acciaio inox. Appoggia il telaio sul tappetino SPV e stendi il biscuit uniformemente, poi posiziona il pettine sul telaio e tiralo verso di te.

Charlotte comb with stainless steel frame. Put the frame on the SPV mat and spread uniformly the biscuit. Place the comb on its frame and pull towards you.



CODE	PETTINE COMB SIZE (mm)	TELAIO FRAME SIZE (mm)
PCT	705x110	570x370x10 h

Pettine - Comb

Pettine con 5 fasce in gomma alimentare a doppio decoro. Spatola uniformemente la pasta decoro sul tappetino SPV, poi appoggia il pettine e tiralo nella direzione desiderata e poni in congelatore. Stendi poi il biscuit aiutandoti con la raplette e cuoci in forno. Infine, appoggia il biscuit su un foglio e togli delicatamente il tappetino SPV.

Comb provided with 5 rubber blades with 2 different decorations. Spread uniformly the decorating paste on the SPV mat. Using the comb rake in the chosen direction. Put it in a freezer. By using the raplette spread the biscuit and bake it. Place the biscuit on a greaseproof paper and carefully remove the SPV mat.



CODE

PETTINE

Raplette



CODE

RAPLETTE

Asciugaverdure - Vegetable dryers

Economico, robusto e sicuro, realizzato a norma CE. Le parti metalliche sono in alluminio ed acciaio inox, gli ingranaggi sono in resina termoplastica antiurto e antiusura. Il modello da 25 litri ha anche la possibilità di scarico diretto dell'acqua residua: è sufficiente applicare la cannetta nell'apposita sede posta sul fondo dello stesso.

Affordable, robust and safe, and made according to CE standards. The metal parts are made of aluminium and stainless steel, the internal components are made of shockproof and wear-resistant thermoplastic resin. The 25 liters model also offers the possibility of directly draining residual water: simply insert the hose in the slot on the base.



CODE	ALTEZZA HEIGHT (mm)	Ø (mm)	CAPACITY (l)	PESO WEIGHT (kg)
GREENMATIC12	430	330	12	2,8
GREENMATIC25	520	430	25	4

Teglie - Trays

Una gamma di teglie solide e robuste, resistenti alla deformazione: forate e piene, rivestite in teflon, in alluminio e in lamiera, con dimensioni e bordi differenti.

A range of solid and sturdy trays, resistant to warping: perforated and non-perforated, coated in teflon, aluminium or steel, in various sizes and with various edge heights.

Teglie piane forate in alluminio - Perforated trays in aluminium



CODE	DIMENSION (mm)	ALTEZZA BORDI EDGES HEIGHT (mm)	SPESSORE THICKNESS
JF04030D20P00G	400x300	20	15/10
JF06040D20P00G	600x400	20	15/10
JF08060D20P00G	800x600	20	15/10

Rivestite in teflon verde 5 mani - 5 layers of green teflon



CODE	DIMENSION (mm)	ALTEZZA BORDI EDGES HEIGHT (mm)	SPESSORE THICKNESS
JF04030D20P00V*	400x300	20	15/10
JF06040D20P00V*	600x400	20	15/10
JF08060D20P00V*	800x600	20	15/10

* Disponibili in 15 giorni lavorativi / Available in 15 working days

Teglie piane piene in alluminio - Flat trays in aluminium



CODE	DIMENSION (mm)	ALTEZZA BORDI EDGES HEIGHT (mm)	SPESSORE THICKNESS
JH04030D20P00G	400x300	20	15/10
JH04030D30P00G	400x300	30	15/10
JH06040D20P00G	600x400	20	15/10
JH06040D30P00G	600x400	30	15/10
JH06040D40P00G	600x400	40	15/10
JH08060D20P00G	800x600	20	15/10

Rivestite in teflon verde 5 mani - 5 layers of green teflon



CODE	DIMENSION (mm)	ALTEZZA BORDI EDGES HEIGHT (mm)	SPESSORE THICKNESS
JH06040D20P00V*	600x400	20	15/10

* Disponibili in 15 giorni lavorativi / Available in 15 working days

Teglie piane piene in lamiera alluminata - Flat trays in aluminated steel



CODE	DIMENSION (mm)	ALTEZZA BORDI EDGES HEIGHT (mm)	SPESSORE THICKNESS
JS04030D20P00G	400x300	20	8/10
JS06040D10P00G	600x400	10	8/10
JS06040D20P00G	600x400	20	8/10
JS06040D30P00G	600x400	30	8/10
JS06040D40P00G	600x400	40	8/10
JS08060D20P00G	800x600	20	8/10

Rivestite in teflon verde 5 mani - 5 layers of green teflon



CODE	DIMENSION (mm)	ALTEZZA BORDI EDGES HEIGHT (mm)	SPESSORE THICKNESS
JS04030D20P00V*	400x300	20	8/10
JS06040D10P00V*	600x400	10	8/10
JS06040D20P00V*	600x400	20	8/10
JS06040D30P00V*	600x400	30	8/10
JS06040D40P00V*	600x400	40	8/10
JS08060D20P00V*	800x600	20	8/10

* Disponibili in 15 giorni lavorativi / Available in 15 working days

Pilly



Un'idea semplice dalla grande efficacia: un piccolo triangolo per impilare e agganciare tra loro teglie da cottura ad angolo retto, in modo sicuro, facile e stabile. Ideale per risparmiare spazio nel laboratorio, nel trasporto per il catering e per sovrapporre i preparati dolci o salati prima, durante e dopo la cottura. Prodotto in silicone alimentare resistente a temperature da -40°C a +250°C. Prodotto brevettato.



A simple idea with great results: a small triangle for stacking and attaching baking trays at right angle to each other in a safe, easy and secure way. Ideal for saving space in the kitchen, transporting for catering and stacking sweet or savoury dishes before, during and after cooking. Food-grade silicone product resistant to temperatures from -40°C to +250°C. Patented product.



CODE	PCS PER KIT
PILLY4	4

Carrelli fissi - Fixed trolleys

Modelli e dimensioni a richiesta, un'ampia scelta di personalizzazioni disponibili e dettagli strutturali pensati per la massima efficienza: guide angolari in acciaio inox AISI 304, ruote termiche resistenti alle alte temperature e cuscinetti per un affiancamento facile e sicuro.

Models and sizes available on request. A wide range of customisations available as well as structural details designed for maximum efficiency: AISI 304 stainless steel angular guides, high-temperature resistant wheels and bearings for easy and safe positioning.

Carrello portateglie a guide angolari - Trolley for trays with angular guides



CODE	DIMENSION (mm)	ALTEZZA HEIGHT (mm)	PIANI LEVELS	DISTANZA PIANI LEVEL SPACING (mm)
YI06040C18SF	600x400	1850	18	90
YI08060C18SF	800x600	1850	18	90

Carrello portateglie a pioli - Trolley with hooks



CODE	DIMENSION (mm)	ALTEZZA HEIGHT (mm)	PIANI LEVELS	DISTANZA PIANI LEVEL SPACING (mm)
YI06040P20SF	600x400	1870	20	80
YI06040P40DF	600x400	1870	40	80

Carrello per forno - Trolley for ovens



Ruote termiche resistenti ad alte temperature.

Thermal wheels resistant to high temperatures.



Carrello porta marne - Trolley for carrying dollies



Estremità guide angolari - Angular guides



chiusa
closed

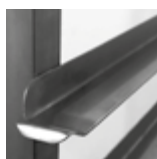

aperta
open

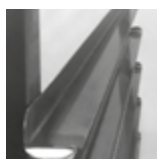

chiusa aperta
closed open

Un contributo essenziale. Il nostro grazie a: A key support. Our thanks to:



La nostra ispirazione. Uno speciale ringraziamento a:
Our inspiration. A special thanks to:



Giuseppe Amato



Nicolas Bacheyre



Antonio Bachour

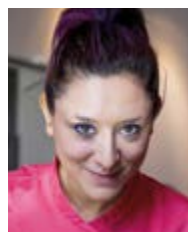

Silvia Federica Boldetti



Massimo Bottura



Karim Bourgi



Davide Comaschi



Carlo Cracco e Marco Pedron



Leonardo Di Carlo



Fabrizio Donatone



Yann Duytsche



Fabrizio Fiorani



Emmanuele Forcone



Gianluca Fusto



Cédric Grolet



Richard Hawke



Stefano Laghi



Diego Lozano



Iginio Massari



Cécile Farkas Moritel



Davide Oldani



Massimo Pica



Olga Penioza



Joakim Prat



Daniel Roos



Maurizio Santin



Paco Torreblanca



Andrea Tortora



Vincent Vallée

Indice alfabetico - Alphabetical index

CODE	PAG	CODE	PAG	CODE	PAG	CODE	PAG
14010	388	133/30	390	BL29*	408	CL02	350
14020	388	133/35	390	BL30*	408	CL03	350
14030	388	133/40	390	BL31*	408	CL04	350
14040	388	40A	397	BL36*	408	CL05	350
14050	388	40B	397	BOTTIGLIA	405	CL06	350
14060	388	40C	397	BR102	65	CL07	350
14070	388	41A	397	BR108	64	CL08	350
14080	388	41B	397	BR109	64	CL09	350
14090	388	41C	397	BR147	64	CL10	350
34013	388	A01	347	BR148	64	CL11	350
34063	407	A02	347	BR149	65	CLA	350
43753	407	A03	347	BRILLSPRAY	352	CM64095	400
43763	407	A04	347	CAG05	405	CM64100	400
125/10	389	A05	347	CAG1	405	CM64105	400
125/12	389	A06	347	CAG2	405	CM64110	400
125/14	389	A07	347	CAG3	405	CM67737	400
125/16	389	A08	347	CAG5	405	CM67739	400
125/18	389	A09	347	CANNELLO	341	CM67741	400
125/2	389	A10	347	CARAMELLOMETRO	341	CM67743	400
125/20	389	A11	347	Carrello per forno	415	CM67777	400
125/4	389	ACIDO CITRICO	357	Carrello porta marne	415	CM67781	400
125/6	389	ACIDO TARTARICO*	357	CCS	394	CM67785	400
125/8	389	AEROGRAFO	409	CD6	53	CM67791	400
126/10	389	AEROPENNA	409	CES	394	CM67793	400
126/12	389	AF001	285	CF05*	123	CM67799	400
126/14	389	AF002	285	CF11	122	CMCS	395
126/16	389	AF003	285	CF12	122	CMES	395
126/18	389	AF004	285	CF13	122	CMGS	395
126/2	389	AF005	285	CF14	122	CMOS	395
126/20	389	AF006	135	CF16	122	CMQS	395
126/4	389	AF007	135	CF19*	123	CMRS	395
126/6	389	AF008	135	CF21	123	CMTNS	395
126/8	389	AGAR AGAR	357	CF22	123	CMTRS	395
127/10	389	ALADIN	340	CF36	123	CMTS	395
127/12	389	AP1	406	CF51	122	CMVS	395
127/14	389	ARGENTO	351	CF52	122	COLINO	405
127/16	389	ARGENTO SC	351	CF58	122	COS	394
127/18	389	B134	64	CF61	122	COVER55	363
127/2	389	B139	64	CF63	122	COVER85	363
127/20	389	B159	64	CGS	394	CQS	394
127/4	389	B161	64	CH1	126	CREMORTARTARO*	357
127/6	389	B162	64	CH2	126	CRS	394
127/8	389	B163	65	CH3	126	CTNS	394
128/10	390	B167	64	CH4	126	CTRS	394
128/12	390	B181	64	CH5	126	CTS	394
128/14	390	B197	65	CH6	126	CVS	394
128/16	390	B204	64	CH7	126	D25QR	67
128/18	390	B702	65	CH8	126	D25T	67
128/2	390	B705	64	CH9	126	D35C	67
128/20	390	B707	64	CH10	126	D35T	67
128/4	390	BAZ	341	CHC	397	D38TR	67
128/6	390	BB25	392	CHELATBL CHEF	408	D3C	67
128/8	390	BB30	392	CHO	397	D3T	67
131/10	390	BB35	392	CHOCOICE	352	D40-O	67
131/12	390	BB4	392	CHQ	397	D45-O	67
131/14	390	BB45	392	CHT	397	D4QR	67
131/16	390	BB5	392	CIOCOPLASTBN	353	D4T	67
131/18	390	BB6	392	CIOCOPLASTMR	353	D51R	67
131/20	390	BIOSSIDO DI TITANIO	357	CIOCOPLASTN*	354	D52R	67
131/22	390	BL17*	408	CIOCOPLASTR*	354	DB10	120
133/20	390	BL21*	408	CIOCOPLASTWH	354	DB14	121
133/25	390	BL24*	408	CL01	350	DB16	121

CODE	PAG	CODE	PAG	CODE	PAG	CODE	PAG
DB16	121	ERS	394	FR034	309	GP05	351
DB18	121	ETNS	394	FR035	307	GREENMATIC12	411
DB33	121	ETRS	394	FR036	308	GREENMATIC25	411
DB35	121	ETS	394	FR037	306	GUANTO/A	407
DB36	121	EVS	394	FR038	304	HYFOAMA	357
DB39	121	FA64	392	FR039	304	IMB10	405
DB41	121	FCH34	127	FR040	305	IMB12	405
DB47	121	FCH64	127	FR041	306	IMB14	405
DB5ORO	120	FF01	299	FR045	308	IMB18	405
DCR	393	FF02	301	FR046	307	IMB8	405
DECOTAB	352	FF03	301	FR047	307	ISOMALTOKG1	340
DECOTABAR*	353	FF04	301	FR048	308	ISOMALTOKG5	340
DECOTABAZ	353	FF05	301	FR049	304	ISOPAV500	340
DECOTABBL	353	FF06	299	FR050	307	JF04030D20P00G	411
DECOTABBN	353	FF08	299	FR052	308	JF06040D20P00G	171-293-411
DECOTABCO	353	FF09	299	FR053	308	JF08060D20P00G	412
DECOTABFU	353	FF10	300	FR056	308	JF04030D20P00V	412
DECOTABG	353	FF11	300	FR064	308	JF06040D20P00V	412
DECOTABN	353	FF12	300	FR065	305	JF08060D20P00V	412
DECOTABR	353	FF13	292	FR067	309	JH04030D20P00G	412
DECOTABRA	353	FF4301	297	FR068	305	JH04030D30P00G	412
DECOTABRC	353	FF4302	298	FR069	307	JH06040D20P00G	412
DECOTABVC	353	FF4303	298	FR070	308	JH06040D30P00G	412
DECOTABVS	353	FF4304	298	FR071	308	JH06040D40P00G	412
DS01	113	FF4305	298	FR073	304	JH08060D20P00G	412
DS02	113	FF4306	297	FR074	304	JH06040D20P00V	412
DV1	346	FF4308	297	FR075	304	JS04030D20P00G	412
DV2	346	FF4311	297	FR076	304	JS06040D10P00G	412
DV3	346	FF4313	292	FR077	305	JS06040D20P00G	412
DV4	346	FLAME	340	FR078	305	JS06040D30P00G	412
DV5	346	FOROSIL43	374	FR096	309	JS06040D40P00G	412
DV6	346	FOROSIL53	374	FR103	309	JS08060D20P00G	412
DV7	346	FOROSIL64	171-374	FRT001	310	JS04030D20P00V	413
DV8	346	FR001	305	FRT002	310	JS06040D10P00V	413
DV9	346	FR002	306	FRT003	310	JS06040D20P00V	413
DV12	346	FR003	304	FRT004	310	JS06040D30P00V	413
DV14	346	FR004	304	FRT005	310	JS06040D40P00V	413
DV15	346	FR005	304	FRT051	310	JS08060D20P00V	413
DV16	346	FR006	307	FRT052	311	KE001	253
DV17	346	FR007	307	FRT053	311	KE002	253
EASYAZ	354	FR008	305	FRT054	311	KE003	253
EASYBL	354	FR009	306	FRT056	311	KE004	254
EASYBN	354	FR010	304	FRT058	311	KE005	254
EASYFU	354	FR011	305	FRT077	311	KE006	254
EASYN	354	FR012	306	FRT103	311	KE007	255
EASYR	354	FR013	307	FRT104	311	KE008	255
ECL20	292	FR014	307	FRT106	311	KE009	255
ECL48	292	FR015	304	FRT120	311	KE010	256
ECS	394	FR016	305	FT250	383	KE011	274
EES	394	FR017	307	FT350	383	KE012	274
EGS	394	FR018	305	FT450	383	KE013	238
ELITE45	386	FR019	308	GIRATU150	382	KE014	244
ELITE55	386	FR020	305	GIRATU200	382	KE015	239
ELITE60	386	FR021	306	GIRATU225	382	KE016	174-245
EMCS	395	FR022	307	GIROIO G	382	KE017	174-245-257
EMES	395	FR023	308	GIROIO P	382	KE018	240
EMGS	395	FR024	306	GIROTRAY	379	KE019	240
EMOS	395	FR025	308	GLA64	171-391	KE020	240-257
EMQS	395	FR026	306	GLICERINA*	357	KE021	273
EMRS	395	FR027	306	GOMMA ADRAGANTE*	357	KE022	272
EMTNS	395	FR028	307	GOMMA ARABICA*	357	KE023	243
EMTRS	395	FR029	305	GOMMA XANTHANO	357	KE024	236-259-260-262
EMTS	395	FR030	306	GP01	351	KE025	242
EMVS	395	FR031	306	GP02	351	KE026	242
EOS	394	FR032	306	GP03	351	KE027	241
EQS	394	FR033	309	GP04	351	KE028	242

CODE	PAG	CODE	PAG	CODE	PAG	CODE	PAG
KE029	244	KT22	47	KT177	37	MACARONRA	356
KE030	241	KT50	20	KT178	35	MACARONVL*	356
KE031	245	KT51	20	KT179	42	MACARONVR*	356
KE032	240	KT60	40	KT180	42	MAGICDECOR	335
KE033	270	KT61	47	KT181	43	MAGICDECOR250	335
KE034	273	KT70	20	KT182	14	MAGICDECOR3	335
KE035	273	KT71	21	KT183	15	MASSPAVONISUMMER	355
KE036	252	KT72	24	KT184	27	MD1*	398
KE037	245	KT74	22	KT185	27	MD2*	398
KE038	244	KT76	22	KT186	11	ME6	398
KE039	243	KT77	22	KT187	10	ME10	398
KE040	272	KT78	24	KT188	13	ME12	398
KE041	271	KT79	24	KT189	26	MM11	103
KE042	241	KT86	44	KT190	12	MM12	103
KE043	237-261-263-265	KT87	46	KTDALLAH	111	MM13	103
KE044	243-265	KT90	23	KTMATRIOSKA	110	MM14	103
KE045	269	KT91	23	L01	348	NC01	344
KE046	272	KT92	23	L02	348	NC02	344
KE047	234	KT120	44	L03	348	NC03	344
KE049S	174-233	KT122	47	L04	348	NC04	344
KE050	235	KT123	56	L05	348	NC05	344
KE051	237-261-263	KT125	41	L06	348	NC06	344
KE052	236-259-260-262	KT126	46	L07	348	NC07	344
KE053	238	KT127	46	L08	348	NC08	344
KE054	239	KT129	21	L09	348	NC09	344
KE055	137	KT130	19	L10	348	NC10	344
KE056	137	KT131	28	L11	348	NC11	344
KE057	137	KT133	44	L12	348	NCP01	345
KE058	249	KT135	39	LAMPADA	341	NCP02	345
KE060	174-252	KT136	37	LB01	349	NCP03	345
KE061	174-252	KT137	39	LB02	349	NCP04	345
KE062	227	KT138	17	LB03	349	NCP05	345
KE063	250	KT139	17	LB04	349	NCP06	345
KE064	251	KT140	19	LB05	349	NCP07	345
KE065	247	KT142	29	LB06	349	NCP08	345
KE066	268	KT143	29	LB07	349	NCP09	345
KE067	267	KT144	56	LB08	349	NCP10	345
KE068	229	KT145	55	LB09	349	NIDODAPE	393
KE069S	230	KT146	56	LB10	349	ORO	351
KE070S	231	KT148	45	LB11	349	ORO SC	351
KE071S	232	KT149	45	LB12	349	P002/335	61
KE998	310	KT150	38	LB13	349	P003/108	62
KE999	310	KT151	38	LL01	350	P004/105	61
KITPL01	328	KT152	39	LL02	350	P005/065	61
KITPL02	328	KT153	41	LL03	350	P011	62
KITPL03	328	KT154	28	LL07	350	P012	62
KITPL04	328	KT155	29	LL08	350	P012/365	61
KITPL05	329	KT156	18	LL10	350	P020	62
KITPL06	329	KT157	17	LL11	350	P021/127	61
KITPL07	329	KT158	25	LS01	115	P023/135	62
KITPL08	329	KT159	111	LS02	115	P030	62
KITPL09	330	KT160	111	LS03	115	P037	62
KITPL10	330	KT162	40	LS04	115	P041/136	61
KITPL11	330	KT163	37	LS05	285	P048	62
KITPL12	330	KT164	37	LS06	115	P053	62
KMS	379	KT165	41	M01	348	P056	62
KS26	369	KT166	45	M02	348	P057/131	62
KS30	32-55-100	KT167	19	M03	348	P073	61
KS32	369	KT168	18	M04	348	P074	62
KS38	369	KT169	21	M05	348	P075	62
KS47	331	KT170	28	M06	348	P078	61
KS48	331	KT172	13	M07	348	P096	61
KS49	369	KT173	16	MACARONBN	356	P109	61
KSSUP	331	KT174	18	MACARONCO*	356	P110	61
KT16	40	KT175	38	MACARONG*	356	P115	62
KT20	40	KT176	36	MACARONR*	356	P150	61

CODE	PAG	CODE	PAG	CODE	PAG	CODE	PAG
P156	62	PC58	81-177	PG7	403	PX032	208
P157	61	PC59	81	PG7TR	403	PX033	212
P168	62	PC60	81	PG8	403	PX034	208
P170	61	PC61	81	PILLY4	413	PX035	211
P203	61	PC62	81	PK001	253	PX036	212
P204	61	PC63	81	PK002	253	PX039	207
P205	61	PC64	81	PK003	253	PX040	210
P206	61	PC65	81	PK004	254	PX041	213
P216	61	PC66	89	PK005	254	PX042	211
P219	62	PC67	89	PK006	254	PX043	224
P332	61	PC68	89	PK007	255	PX044	224
P339	62	PC69	89	PK008	255	PX045	222
P348	62	PC100	97	PK009	255	PX046	222
P397	61	PC101	97	PK010	256	PX047	223
P417	61	PC102	97	PL01	328	PX048	224
P418	61	PC103	98	PL02	328	PX051	210
P428	62	PC104	98	PL03	328	PX052	210
P468	62	PC105	98	PL04	328	PX053*	213
PASTAMICA	356	PC106	97	PL05	329	PX054	210
PAVOGEL	331	PC107	97	PL06	329	PX055	211
PB12	391	PC108	97	PL07	329	PX056	213
PB24	391	PC109	98	PL08	329	PX057	212
PC01	93	PC110	98	PL09	330	PX058	277-278-279
PC02	93	PC111	98	PL10	330	PX059	279
PC03	93	PC112	98	PL11	330	PX060	279
PC04	93	PC113	97	PL12	330	PX061	257
PC05	93	PC114	97	PM54128	400	PX063	210
PC06	93	PC115	98	PM54129	400	PX064	208
PC07	93	PC5000	77	PM54130	400	PX065	209
PC08	93	PC5001	74	PM64005	400	PX066	209
PC09	93	PC5002	75	PM64010	400	PX067	209
PC10	93	PC5003	76	PM64012	400	PX068	208
PC11	94	PC5004	71	PM64025	400	PX069	209
PC12	94	PC5005	72	POMPETTA	341	PX070	209
PC13	94	PC5006	73	PVF0600400	373	PX071	287
PC14	94	PCT	410	PW040	387	PX072	287
PC15	94	PD1*	398	PW045	387	PX073	288
PC16	94	PECTINA	357	PW050	387	PX074	288
PC17	94-177	PETTINE	410	PX001	208	PX075	257
PC18	94	PF1	396	PX002	213	PX076	257
PC19	94	PF2	396	PX003	210	PX077	257
PC20	94	PF2A	396	PX004	209	PX078	208
PC21	94	PF3	396	PX005	211	PX300	225
PC22	94	PF300	396	PX006	225	PX301	225
PC23	93	PF3A	396	PX007	212	PX302	223
PC36	93	PF4	396	PX010	212	PX303	221
PC37	94	PF4A	396	PX011	224	PX304	221
PC38	80	PF5	396	PX012	224	PX305	225
PC39	80	PF5A	396	PX013	224	PX306	222
PC40	80	PF6	396	PX014	210	PX307	213
PC41	80	PF6A	396	PX015	211	PX3200	169-179
PC42	80	PF7	396	PX016	208	PX3201	169
PC43	80	PF7A	396	PX017	223	PX3202	169
PC44	80	PF8	396	PX018	210	PX3203	169
PC45	80	PF8A	396	PX019	212	PX3204	169
PC46	80	PF9	396	PX020	224	PX3205	169-179
PC47	81	PF10	396	PX021	212	PX3206	169-179
PC48	81	PF10A	396	PX022	224	PX3207	169
PC49	85	PF11	396	PX023	209	PX3208	167
PC50	95	PF12	396	PX024	208	PX3209	167
PC51	85	PF13	396	PX025	211	PX3210	167-179
PC52	85	PF14	396	PX026	212	PX3211	167
PC53	85	PF15	396	PX027	211	PX3212S	321
PC55	85-177	PF18	396	PX029	213	PX4301	198
PC56	81	PG3*	403	PX030	209	PX4302	200
PC57	81	PG4*	403	PX031*	211	PX4303	198

CODE	PAG	CODE	PAG	CODE	PAG	CODE	PAG
PX4304	201	PX4377S	194	SD117	119	SFP2	127
PX4305	175-196	PX4378	217	SD118	118	SFP3	127
PX4306	200	PX4382S	195	SD120	120	SFP4	127
PX4307	197	PZ11	53	SD126	117	SFP5	127
PX4308	199	RA1RS	399	SD127	117	SFP6	127
PX4309*	278	RA2RS	399	SD129	117	SFP7	127
PX4310*	278	RA3RS	399	SD12B	119	SFP8	127
PX4311*	278	RA4RS	399	SD131	117	SFP9	127
PX4312	200	RA5RS	399	SD132	117	SFP10	127
PX4313	283	RA6RS	399	SD133	117	SH01	57
PX4314	283	RA7RS	399	SD134	117	SH02	55
PX4315	283	RA8RS	399	SD135	117	SM01	346
PX4316	283	RA9RS	399	SD136	117	SM02	346
PX4317	199	RA10RS	399	SD137	117	SM03	346
PX4318*	278	RAPLETTE	410	SD138	117	SM04	346
PX4319*	278	RC1	402	SD139	119-177	SM05	346
PX4320*	277	RC2	402	SD13ORO	120	SM06	346
PX4321	201	RC3	402	SD15G	119	SM07	346
PX4322	199	RC4	402	SD15M	119	SM08	346
PX4323	219	RC5	402	SD19B	119	SM09	346
PX4324	219	RC6	402	SD20ORO	119	SMD03	336
PX4325	175-218	REALGHIACCIA	355	SD36G	119	SMD04A	336
PX4326	219	RG1	341	SD38G	120	SMD04B	336
PX4327	201	RG2	409	SD39G	119	SMD05	336
PX4329	202	RM13	399	SD40G	119	SMD07A	336
PX4330	202	RM16	399	SD41G	119	SMD07B	336
PX4331	202-203	RM18	399	SD42R	120-177	SMD08	336
PX4332	203	RM20	399	SD44G	119	SMD09	336
PX4333	203	RM22	399	SD45B	120	SMD10	336
PX4334S	205	RM24	399	SD56ORO	120	SMD102	336
PX4335S	204	RM28	399	SD61	120-177	SMD11	336
PX4336S	205	RP1	403	SD73	120	SMD12	336
PX4337S	204	RP2	403	SD75	120	SP01250	347
PX4338	201	RP3	403	SD76	120	SP02250	347
PX4339	283	RP4	403	SD77	120	SP03250	347
PX4340	193	RP5	403	SD83	120-177	SP04250	347
PX4341	193	S01	349	SD87	53	SP05250	347
PX4342	198	S02	349	SD88	53	SP06250	347
PX4343	196	S03	349	SEM100	404	SP07250	347
PX4345	196	SALI DI SILICIO	357	SEM1000	404	SP08250	347
PX4346	218	SCARPADECOLTE	57	SEM1500	404	SP1	407
PX4348	218	SCIROPPO DI GLUCOSIO	357	SEM2000	404	SP2	407
PX4349	197	SCR16	398	SEM300	404	SP3	407
PX4350	283	SCR18	398	SEM500	404	SP1001S	100
PX4351S	192	SCR20	398	SES100	404	SP1002S	100
PX4352S	192	SCR24	398	SES1000	404	SP1003S	100
PX4353S	183	SCR28	398	SES25	404	SP1024S	101
PX4355	193	SD090	118	SES250	404	SP1025S	101
PX4356	191	SD092*	118	SES50	404	SP1032S	101
PX4357	136	SD094	118	SES500	404	SP1045S	101
PX4358	136	SD095	118	SET1000	404	SP1064S	101
PX4359	136	SD096	118	SET150	404	SP1073S	101
PX4360S	191	SD097	118	SET2000	404	SP1082S	101
PX4361	190	SD099	118	SET250	404	SP1156S	101
PX4362	191	SD100	118	SET500	404	SP1214S	101
PX4363	175-190	SD101*	118	SET750	404	SP1217S	100
PX4364	190	SD102*	118	SETACCIOG05	406	SP1219S	101
PX4365	192	SD103	119	SETACCIOG1	406	SP1244S	101
PX4369	289	SD104	117	SETACCIOP05	406	SP1327S	101
PX4370S	175-196	SD105*	117	SETACCIOP1	406	SP1334S	101
PX4371	186	SD106	118	SF1M	406	SP2002S	100
PX4372	197	SD107	118	SFERA100	339	SP2251S	100
PX4373	185	SD109*	118	SFERA150	339	SP2252S	100
PX4374	189	SD110*	118	SFERA80	339	SP2253S	100
PX4375	188	SD111	118	SFP	127	SP2254S	100
PX4376	187	SD115	117	SFP1	127	SP300	384

CODE	PAG	CODE	PAG	CODE	PAG	CODE	PAG
SP301	384	T705	109	TMD03	336	TRS2	394
SP302	385	T706	108	TMD04	336	TRSD11	337
SP303	385	T709	108	TMD05	337	TRSD12	337
SPIL2	379	T803 + KS30	33	TMD06	337	TRSD13	337
SPV43	375	T821	176	TMD07	337	TRSD14	337
SPV53	375	T822	50	TMD08	337	TRSD14-2	337
SPV6242	375	T826	49	TMES	395	TRSD15	337
SPV64	375	T827	49	TMES2	395	TRSD15-2	337
SPV64MACARONS	375	T828	51	TMGS	395	TRSD16	337
SPV86	375	T829	50	TMGS2	395	TRSD16-2	337
SPV88	375	T830	31	TMOS	395	TRSD17	337
SRP	399	T831	32	TMOS2	395	TRSD17-2	337
STP00	401	T832	31	TMQS	395	TTNS	394
STP30D	401	T834	51	TMQS2	395	TTNS2	394
STP31	401	T835	49	TMRS	395	TTRS	394
STP33	401	T836	49	TMRS2	395	TTRS2	394
STP34	401	T837	50	TMTNS	395	TTS	394
STP44	401	T838	50	TMTNS2	395	TTSD2	394
STP46	401	T839	32	TMTRS	395	TVS	394
STP52B	401	T840	32	TMTRS2	395	TVS2	394
STP52D	401	T841	33	TMTS	395	TX01	275
STP53B	401	T842	107	TMTS2	395	TX02	275
STP540B	401	T843	32	TMVS	395	TX03	275
STP54B	401	T844	33	TMVS2	395	TX04	275
STP54L	401	T845	50	TOP01	261	VC1	369
STP55L	401	T846	50	TOP02	265	VC2	369
STP57	401	T847	50	TOP03	265	VC4	369
STP58N	401	T848	33	TOP04	265	VC5	369
STP59	401	T849	33	TOP05	259	VE1	408
STP61B	401	T850	33	TOP06	259	VE1A	408
STP63	401	T851	33	TOP07	259	VE1G	408
STP64	401	T852 + KS49	108	TOP08	263	VE2	408
STP65	401	T854	49	TOP09	262	VE2A	408
STP67	401	T855	49	TOP10	262	VE2G	408
STPROML	401	T856	31	TOP11	263	VL65	314
STRIP30FPC	373	T857	31	TOP12	261	VL140	314
STRIP40FPC	373	T858	107	TOP13	260	VL160	314
STRKIT1	124	T907	108	TOP14	260	VL180	314
STRKIT2	124	T918	51	TOP15	264	VL200	314
T64G	379	T925	109	TOP16	264	VL220	314
T100	52	T927	176	TOP17	147	VL240	314
T104 + KS30	53	T965	32	TOP18	147	VL4030	315
T108	52	T966	32	TOP19	147	VL4035	315
T110	107	T981	52	TOP100	325	VL6430	315
T111	32	T983	52	TOP101	325	VL6435	315
T113 + KS30	33	T997	52	TOP102	325	VL6440	315
T114 + KS30	108	T998	52	TOP103	325	VM1B	365
T115 + KS38	108	TARTARUGA	393	TOP104	325	VM2B	365
T225/G	176	TB05	337	TOP105	325	VM3B	365
T231	52	TCS	394	TOP106	325	VP1BN	367
T231/A	52	TCS2	394	TOP107	325	VP1NR	367
T234	51	TES	394	TOS	394	VP1T	367
T235	51	TES2	394	TOS2	394	VP2BN	367
T260	51	TFOOT-30	108	TP01	402	VP2NR	367
T287	50	TFOOT-70	108	TP02	402	VP2T	367
T290	51	TG1002	397	TP03	402	VP3BN	367
T401	109	TG1009	397	TP04	402	VP3NR	367
T405	109	TG1021	397	TP5	402	VP3T	367
T406	109	TGS	394	TP6	402	W200	409
T407	109	TGS2	394	TP7	402	X01	170
T502	51	TH5986S	406	TQS	394	X02	170
T506*	108	TH5989	406	TQS2	394	X03	155
T605	31	TMCS	395	TRAY	363	X04	155
T608	31	TMCS2	395	TRAYGEL	331	X05	155
T611	32	TMD01	336	TRAYGELMINI	331	X06	155
T704 + KS30	53	TMD02	336	TRS	394	X0602	165

CODE	PAG	CODE	PAG	CODE	PAG
X07	156	X4030	159	XF32	151
X08	156	X4032	159	XF7020	163
X0802	170	X4034	159	XF9020	170
X1002	170	X4036	159	XFO197020	154
X1202	149-158	X411836	159	XFO197035	154
X121220	155	X413040	159	XFO299020	154
X1402	149-158	X414060	159	XFO299035	154
X1403 □	158	X421836	159	XFO656520	163
X141420	155	X423040	159	XO186020	154
X1602	149-158	X424060	159	XO288020	154
X1603 □	158	X7718	159	YI06040C18SF	414
X161620	155	X7720	159	YI06040P20SF	414
X17	165	X7722	159	YI06040P40DF	414
X18	165	X7724	159	YI08060C18SF	414
X1802	149-158	X7726	159	ZUCCHERO INVERTITO	357
X1803 □	158	XF01	170		
X181820	155	XF02	170		
X186020	156	XF03	155		
X19	165	XF04	155		
X20	165	XF05	155		
X2002	149-158	XF06	155		
X21	165	XF07	156		
X22	165	XF08	156		
X2202	149-158	XF09	156		
X23	152	XF10	156		
X24	152	XF11	163		
X2402	149-158	XF1120	170		
X25	153	XF12	163		
X26	153	XF13	163		
X2602	158	XF14	163		
X27	152	XF15	163		
X28	152	XF151520	155		
X2802	158	XF151535	155		
X288020	156	XF1520	149		
X29	153	XF1535	149		
X30	153	XF16	163		
X31	151	XF17	152		
X32	151	XF1720	149		
X33	151	XF1735	149		
X34	151	XF18	152		
X35	151	XF19	153		
X37	165	XF191920	155		
X3910	158	XF191935	155		
X3912	158	XF1920	149		
X3914	158	XF1935	149		
X3916	158	XF197020	156		
X3918	158	XF197035	156		
X3920	158	XF20	153		
X3922	158	XF21	152		
X3924	158	XF2120	149		
X3926	158	XF2135	149		
X3928	158	XF22	152		
X3930	158	XF23	153		
X3932	158	XF2320	149		
X3934	158	XF2335	149		
X3936	158	XF24	153		
X4010	158	XF25	151		
X4012	158	XF2520	149		
X4014	159	XF26	151		
X4016	159	XF27	151		
X4018	159	XF28	151		
X4020	159	XF29	151		
X4022	159	XF299020	156		
X4024	159	XF299035	156		
X4026	159	XF30	151		
X4028	159	XF31	151		

* fino a esaurimento
subject to availability

□ nuovi prodotti
new products

Tutti gli articoli PAVONI ITALIA sono realizzati con materiali idonei al contatto di sostanze alimentari in conformità alle nuove disposizioni di legge. Le fotografie del presente catalogo non sono impegnative. I pesi e le misure possono essere soggetti a variazioni.

All PAVONI ITALIA items are made of materials suitable for food contact, in compliance with the new legal provisions. The pictures in this catalogue are not binding. Weights and measurements may be subject to variations.



Pavoni Italia S.p.a.

Via E. Fermi, s.n. - 24040 Suisio (BG) - Italia
T. +39 035 4934111 - F. +39 035 4948200
info@pavonitalia.com - www.pavonitalia.com



Management
System
ISO 9001:2015



www.tuv.com
ID 9105056998